

Traffic Signal Guidelines

Index of Standard Drawings

<u>Drawing No.</u>	<u>Title</u>	<u>Sheets</u>	<u>Date</u>
S-51.0	Typical Location of Traffic Signal Standards	1	01-31-02
S-55.0	Typical Layout for Activated Pedestrian Warning Device	1	06-24-10
S-60.0	Fire Station Warning Beacons	1	11-20-15
S-65.0	Mastarm Signal Head Replacement	2	01-30-06
S-70.0	Limit Line Inductive Loop Detector Placement	2	03-20-13
S-73.2	Accessible Pedestrian Signal (APS)	2	08-09-16
S-75.0	Special Detector Applications	6	03-03-09
S-85.0	Application of Visibility-Limited Traffic Signal Heads	11	01-30-06
S-100.0	Operation and Design of Signalized Jogged Intersections	12	06-24-10
S-101.0	Typical Traffic Signal Layouts	8	06-24-10
S-102.0	Mastarm Signal Head Installation Criteria	1	11-13-98
S-103.0	Criteria for 12" Signal Heads	1	03-27-08
S-418.6	Overhead Guide Signing	16	07-27-10
S-497.0	Restricted Sight Distance Criteria for Protected Left-Turn Phasing	7	12-26-00

 Department of Transportation	MANUAL OF POLICIES AND PROCEDURES	SECTION NO. 521
	SUBJECT Traffic Signal Design Guidelines	DATE 9/2010
		PAGE 1 OF 18

Plan Preparation

Traffic signal design plans are required for new signals, relocation of signal hardware, changes in signal hardware other than routine maintenance, interconnection, overhead signs, electric signs, variable message signs, beacons, traffic monitoring cameras, detection or changes in traffic islands, curb lines, signal phasing and significant relocation of pavement marking features.

Traffic signal design plans generally shall be prepared by the Signal Design Section or the ATSAC Design Section for projects involving City streets. Exceptions are as follows:

- Plans prepared by consultants for private entities as part of the B-Permit process;
- Plans prepared by consultants pursuant to an agreement with a governmental agency;
- Plans prepared by employees of another governmental agency; and
- Projects for which the Bureau Head or higher authority has approved plan preparation by a non-governmental entity.

Plan Approval

All traffic signal design plans for which the location is wholly under the jurisdiction of the City of Los Angeles shall be signed as follows:

- By the Section Head of the Signal Design Section or ATSAC Design Section, unless that person is absent; and
- By the Division Head of the Design Division or ATSAC Design and Construction Division, unless that person is absent; and
- By the Bureau Head responsible for those divisions, unless that person has delegated approval authority to the Division Head whose division initiated the plan.

Traffic signal design plans submitted by another governmental agency for traffic signal equipment not maintained by the City of Los Angeles shall require the signature of the Bureau Head responsible for the Design Division, or the Division Head if approval authority has been so delegated.

The practice of traffic engineering requires that traffic signal design plans be signed and stamped by Civil Engineers or Electrical Engineers registered in the State of

Department of Transportation MANUAL OF POLICIES & PROCEDURES	SUBJECT Traffic Signal Design Guidelines	SECTION 521	DATE 9/2010	Page 2
---	---	----------------	----------------	-----------

California. Accordingly, the final approval authority for plans prepared by the Department shall be so registered and shall sign and stamp said plans. Consultants or other persons submitting traffic signal plans to the Department shall be so registered and shall sign and stamp said plans.

B-Permit consultants submitting plans shall meet two other requirements. First, they must have a Business License in the City of Los Angeles. Second, they must indicate on the plan that the plan has been reviewed by a person who is either registered as a Traffic Engineer in the State of California or who has a Professional Traffic Operations Engineer Certificate issued by the Institute of Transportation Engineers.

Plan Review

Traffic signal plans are to adhere to the California Manual on Uniform Traffic Control Devices, the California Vehicle Code, LADOT Standard Plans and text herein. In using these sources optional or “may” conditions are to be determined using engineering judgment. Recommended or “should” conditions are to be incorporated, unless there is a compelling reason to deviate. Mandatory or “shall” conditions are to be followed without exception. Recommended and mandatory conditions in the Standard Plans and text that exceed national and State standards do not apply to plans approved prior to the adoption date of this section of the Manual of Policies and Procedures.

In preparing or reviewing signal plans the Signal Design Section or ATSAC Design Section shall be responsible for ensuring that plans adhere to the above, while incorporating critical information and concerns communicated by the LADOT District office or other sections of the Department, particularly the Signal Timing Section on matters related to signal phasing. In considering all input, the plan shall represent the best recommendation of the Signal Design Section or the ATSAC Design Section. Design and operational issues should be coordinated at the Associate III, Section Head or Division Head levels, if necessary, for resolution. The operational preference of the LADOT District office generally should prevail for discretionary operational matters. Their concurrence shall be indicated by showing their initials along with the concurrence date in the title box. If the in-progress plan shows significant or operational changes after it is initialed by the LADOT District office, or others who previously reviewed the plan, then it requires rerouting for concurrence, with a new date shown on the plan.

Plans more than two years old prior to installation should be newly reviewed for: any change in field conditions; appropriateness of the proposed signal design previously approved; and application of current design standards. Where changes are necessary, a superseding plan or revision shall be prepared.

To the extent feasible, projects initiated for other purposes should incorporate, operational or safety improvements desired by the Department. Such projects might include street widening, street lighting, storm drain, B-Permits and ATSAC. The extent of the additional work, deadlines or other factors occasionally may present difficulties in

Department of Transportation MANUAL OF POLICIES & PROCEDURES	SUBJECT Traffic Signal Design Guidelines	SECTION 521	DATE 9/2010	Page 3
---	---	----------------	----------------	-----------

including them with the initial project. In these cases an assured project shall be identified to include the improvements or another plan shall be initiated to include them.

Signal Plan Implementation

Approved signal plans are to be implemented as shown in the table below:

<u>Initiation of Project</u>	<u>Implementation By</u>
Department-Initiated	LADOT Field Forces
Department-Initiated, Special Funds	LADOT Field Forces or Contractor
Street Resurfacing	LADOT Field Forces
B-Permits (Developers)	B-Permit Contractor
City Contracts & CIP	City Contractor
Non-City Public Agency	Their Contractor or by LADOT Field Forces, per an approved agreement

For work generally to be performed by LADOT field forces, elements such as trenching, detector installation, etc. may be contracted out at LADOT's discretion. For work to be performed entirely by contractors on City streets, LADOT and the Bureau of Contract Administration must inspect and approve the signal work.

On occasion and at its discretion, the Department may use programmed funds so identified in LADOT's budget or in the CIP to perform all or part of the work by contract rather than by LADOT field forces. If the work is for routine construction of limited scope, then a low-bid contract can be awarded through the Department of General Services. Projects of larger scope, which require the plan processing services of the Bureau of Engineering and the contract inspection services of the Bureau of Contract Administration, should be awarded through the Board of Public Works.

Plan Format

All traffic signal plans shall use the latest version of AutoCAD, as menu-enhanced for use by LADOT, except for those plans exempted by the Bureau Head for emergency purposes. Traffic signal plans prepared by other agencies having partial or total jurisdiction over the location should use the prescribed AutoCAD format. However, if the agency is not conversant with LADOT's format and prepares the plans in another format, then LADOT staff shall initiate AutoCAD replacement plans immediately upon approval of the non-conforming plans for all locations maintained by LADOT field forces. Right-of-way, roadway features, striping and other traffic control devices relevant to the traffic signal plans shall be layered to reflect "existing," "to-be-removed" and "to-be-added" conditions for each stage of construction, using specified line thicknesses and spacing.

The symbols shown in scale on Standard Drawing S-50.1 shall be used in the sizes shown. A sample drawing illustrating the format and a compact disk of the menus,

Department of Transportation MANUAL OF POLICIES & PROCEDURES	SUBJECT Traffic Signal Design Guidelines	SECTION 521	DATE 9/2010	Page 4
---	---	----------------	----------------	-----------

layering, symbols, line thickness and pen assignments, shall be available to consultants and other agencies.

All signal plans shall be prepared to a scale of one-inch equals 20 feet, except where a different scale is approved by the Section Head, often due to the large expanse of an intersection complex. All overhead static and variable message signs should be drawn to a horizontal scale of one inch equals 40 feet, so as to identify the general location, street lighting and related geometric features along the route near the installation. In addition, on a cross-section scale of approximately one-inch equals 5 feet, the plan shall include details of the sign. These details shall include panel size, size and type of legend, background and legend colors, type of reflective sheeting, legend spacing, relative position of panel and legend with respect to curb line and striping, type of mounting, type of overhead standard, type of illumination, relevant specifications and any reference to standard drawings.

Plans should be drawn on 24-inch by 36-inch mylar 3.0 mils (0.003 inch) thick, with a specified border, title block, signature block, "As-Built" block, "Signal Standard Schedule" and "Conductor Schedule." In addition, if the work is to be done by contract, a "Notice to Contractor" listing of notes, an "Estimated Materials Furnished by LADOT" table and an "Estimated Salvaged Materials To Be Returned to LADOT" table shall be included.

Up to three minor oversights may be individually corrected on the mylar copy of an AutoCAD plan if the change has been made to the electronic copy.

Base Plan Contents

Base plans shall show at least 50 feet of each leg of the intersection and all intersections or functions operated by the same controller.

Base plans shall accurately depict:

- All roadway features (existing, removed and proposed), including curb lines, legal center lines, property lines, edges of pavement, edges of paved sidewalks, curb returns, curb ramps, driveways and bus pads.
- Striping (existing, removed and proposed).
- Nearby underground utilities, sub-structures, basements and vaults (associated with the after condition).
- Nearby above-ground structures (including bus shelters), above-ground cable and permanent street furniture (associated with the after condition).
- All existing or proposed bushes and trees greater than four feet in height and within 50 feet of any signal standard, with the outer perimeter of the foliage accurately shown.

Department of Transportation MANUAL OF POLICIES & PROCEDURES	SUBJECT Traffic Signal Design Guidelines	SECTION 521	DATE 9/2010	Page 5
---	---	----------------	----------------	-----------

- Existing, removed and proposed below and above-ground signal equipment.
- Regulatory signs which govern pedestrian and vehicular moves at the intersection.
- Other field conditions which might affect a design decision.

Field Checks

Field checks shall be conducted for each plan that is prepared. Field checks shall confirm, to the extent feasible, all base plan contents. Conditions should be photographically documented for future reference purposes. Documentation should include:

- Viewing at 50 feet and 250 feet (approximately) on each approach to the intersection
- Two close-ups at each corner of existing signal hardware, surface conditions and above-ground features
- Special conditions (such as trees) which might affect a design decision.

Plan Coordination

The Signal Design Section or the ATSAC Design Section shall be responsible for ensuring that the traffic signal plan is coordinated and compatible with the striping plans, signal system operation and street lighting proposals. In this regard, the plan shall be coordinated with other involved sections of the Department, as necessary, such as the Geometric Design Section and the Signal Timing Section.

Special Projects

The Signal Design Section is responsible for understanding how the improvements shown on an individual plan or set of plans are integral to the goals and requirements of larger projects, such as major land development projects or major street construction projects. This knowledge ultimately will lead to improved design decisions. If the information is not directly submitted, the Section is responsible for seeking the information from project managers or other sources as necessary.

Complex Designs

Complex, unusual, novel or trial designs or methods of operation for major projects should be reviewed by senior management staff before proceeding beyond the preliminary stage. If the project design is initiated outside of the Design Division, then the Design Division Head shall ensure that an internal review and concurrence by a departmental street improvement committee has taken place. This procedure will help to ensure that new designs are properly scoped, well developed and not problematic.

Department of Transportation MANUAL OF POLICIES & PROCEDURES	SUBJECT Traffic Signal Design Guidelines	SECTION 521	DATE 9/2010	Page 6
---	---	----------------	----------------	-----------

Plan Processing

All signal plans and related documentation submitted for LADOT review by consultants or other agencies shall be submitted to the Plan Processing Control Desk of the Design Division which will route the plans to the Signal Design Section.

Signal plans submitted by Caltrans or another agency that are part of a larger joint project, shall be submitted first to the Interagency Coordination Section for evaluation. If acceptable, the Interagency Coordination Section shall subsequently submit them to the Plan Processing Desk or brief the design staff and/or Department management, as appropriate.

The Signal Design section shall seek documentation supporting any operational changes proposed in the plan from consultants submitting plans. Proposed operational changes require justification using realistically projected traffic volumes associated with the immediate phase of land development or re-development and yet should anticipate the operational needs for ultimate build-out of the final phase of related land development.

Plans that are being submitted for approval by consultants shall include two mylar originals and a compact disk. One of the mylar originals is to be returned to the consultant after plan approval. It is the responsibility of the consulting project engineer to ensure that the contents of the compact disk are consistent with those on the mylar plan and that any minor oversights that have been manually corrected on the mylar copy of an AutoCAD plan have been incorporated on the compact disk prior to approval of the plan.

After the plan is approved, the electronic file shall be modified in a timely manner by the Signal Design Section to show in printed form the names, initials and dates of all persons who were part of the design approval and submittal.

As-Built Plans

As-Built plans are an important part of the record of field conditions as of a certain date. The electronic files of said plans shall be timely revised for all implemented plans.

The LADOT signal yard supervisor or his designee is required to verify that the work shown on the signal plan has been completed by LADOT crews, whereas the LADOT field signal electrician inspector is required to verify that the work shown on non-ATSAC signal plans has been completed by contractors. The ATSAC Construction Section Head or his designee is required to verify that the work shown on ATSAC signal plans has been completed. Verification of completion shall include verification of all traffic control devices shown on the plan. Construction-related changes and other differences shall be shown in red. Each of these persons is responsible for timely notification to the Signal Data Records Unit of the verification of work and the date of

Department of Transportation MANUAL OF POLICIES & PROCEDURES	SUBJECT Traffic Signal Design Guidelines	SECTION 521	DATE 9/2010	Page 7
---	---	----------------	----------------	-----------

completion. The Signal Data Records Section then becomes responsible for timely notification to the Signal Design Section. The Signal Design Section shall record on the LADOT plan "As Built" or "Condition As Of," along with the date and shall revise the file plan to show any construction-related change orders. The electronic file of the plan shall then be revised in a timely manner to show the same information.

Signal Plan Distribution

Signal plans shall be distributed as follows:

- For projects to be completed by LADOT field forces, one copy to the appropriate LADOT District office, one copy to the Signal Timing Section, and six copies to the Field Coordination Section by the Signal Design Section.
- For B-Permit and CIP projects, one copy to the appropriate LADOT District office, one copy to the Signal Timing Section and two copies to the appropriate LADOT Yard by the Signal Design Section.
- For ATSAC projects, one copy to the appropriate LADOT District office, one copy to the Signal Timing Section and two copies to the appropriate LADOT Yard by the ATSAC Design Section.

As-Built plans shall be distributed by the Signal Design Section or ATSAC Design Section with one copy to the appropriate LADOT District office, two copies to the appropriate LADOT Yard and one copy to the ATSAC Center, if in an ATSAC area.

Signal Plan Files

All current "As-Built" and proposed signal interconnect plans and traffic signal plans (mylars and electronic files) shall be stored in the Signal Design Section as the City's official record. Sections of the Department, other than the Signal Design Section, that may prepare traffic signal plans shall timely provide the Signal Design Section with a mylar copy and compact disk of the plan as soon as the related plan set is completed. When the plan set is constructed, the initiating unit of the Department shall timely provide an "As Built" plan and compact disk to the Signal Design Section. Provision of said plans includes their filing in a manner acceptable to the Signal Design Section.

There shall be one comprehensive Signal Plan File in the Signal Design Section for all plans for traffic control signals, beacons, overhead signs, electric signs, variable message signs and traffic monitoring cameras. In addition, there shall be a separate comprehensive file in the Signal Design Section for signal interconnect plans. Other LADOT sections may retain copies and electronic files of the plans.

Superseded "As Built" plans shall be sent to the Master File.

Filed signal plans shall not be removed from the file except for brief reference or copying. If prolonged reference to a plan is needed, then a photocopy or print copy shall be made.

Department of Transportation MANUAL OF POLICIES & PROCEDURES	SUBJECT Traffic Signal Design Guidelines	SECTION 521	DATE 9/2010	Page 8
---	---	----------------	----------------	-----------

Plan Titles

- Numeric-Alpha Order

All plans shall be filed and listed by all units of LADOT in numeric-alpha order, with the lowest numbered streets and intersections (if the number appears before the street title) listed before the alphabetic order of named streets and intersections. Numbered streets shall use Arabic numerals and shall not be fully-spelled.

Accordingly, “1st Street” not “First Street” is used. In addition, “4th Avenue” is filed under the number “4,” since the number appears before the street title; whereas “Avenue 26” is filed under “A” since the number does not appear first.

- Five-Digit Code

Below the numeric-alpha title shall be a distinct five-digit code number which shall be consistent throughout LADOT with those used on timing charts and other records.

- Official Names

If there is any doubt regarding the official name of a public roadway after referring to the Thomas Guide, the agency which operates the roadway should be consulted. Within the City the designated agency is the Bureau of Engineering, while for freeways it is Caltrans. For identification purposes, freeway names, not route shield numbers, shall be used.

The names shall not be abbreviated but street titles which appear after the name may be abbreviated. Where a name has several words, the plan is to be filed under the first word.

Examples which illustrate the above are shown below:

1. “North Main Street” is filed under “N” and exists northeasterly of Alameda Street, whereas Main Street is filed under “M” and exists southeasterly thereof. A cardinal direction within an address number, such as 200 N. Main Street, is not part of the street name.
2. “Hollywood Freeway” exists northwesterly of the Harbor Freeway/Pasadena Freeway junction and “Santa Ana Freeway” exists southeasterly thereof.
3. The official name is “Glenn M. Anderson Freeway” (filed under “G”), not “Century Freeway.”

Department of Transportation MANUAL OF POLICIES & PROCEDURES	SUBJECT Traffic Signal Design Guidelines	SECTION 521	DATE 9/2010	Page 9
---	---	----------------	----------------	-----------

4. The official name is “Ronald Reagan Freeway,” not Simi Freeway nor “118 Freeway.”
5. “John S. Gibson Boulevard” is filed under “J,” not “G.”
6. The official name is “Martin Luther King, Jr. Boulevard,” (filed under “M”), not “ML King Boulevard” nor “King Boulevard.”

- Intersection Names

The names of roadways to be shown in the plan title shall include:

1. All intersecting legs of named public roadways (including freeway names) and officially named private streets operated by the same signal controller; and
2. All driveway approaches, unless the plan title already includes the names of at least two public roadways. Driveway names, when necessary, shall be named on the plan and then officially requested in writing so as to ensure that they are included in the 911 Emergency system and in the Thomas Guide. They should be requested through the Land Development Section of the Development Services Division of the Bureau of Engineering for eventual approval by the City Council. For a new signalized driveway, the B-Permittee should be given the first opportunity to name it. Otherwise, driveway names should be selected based on the commonly known name of the land development served.

Examples which illustrate the above are described below:

1. “Fairfax Avenue, Olympic Boulevard and San Vicente Boulevard” is shown on one plan and not two plans since this intersection complex is operated by one signal controller.
2. “Courtyard Place and Wilshire Boulevard” incorporates the name of a private street.
3. “Malcolm Avenue and Pico Boulevard” does not include the name of the approach driveway serving the Westside Pavilion regional shopping center because the intersection name already includes the name of two public roadways.
4. “Beverly Center Driveway and La Cienega Boulevard” incorporates the name of the driveway since there is no other intersecting public street and the Beverly Center regional shopping center is the commonly known name shown in the Thomas Guide.

Department of Transportation MANUAL OF POLICIES & PROCEDURES	SUBJECT Traffic Signal Design Guidelines	SECTION 521	DATE 9/2010	Page 10
---	---	----------------	----------------	------------

5. "Alvarado Street and Hollywood Freeway Northbound Ramps" includes the freeway name (versus route shield number) and uses the plural form of the word, "ramp", since there is both an approach off-ramp and a departure on-ramp.

- Midblock Names

For naming purposes, midblock locations are considered to be those locations neither within a signalized intersection nor at a signalized driveway. They include signalized crosswalks not at signalized driveways. They may include overhead signs, variable message signs and electric signs not at a signalized intersection.

The first name shall include the route on which they are located. The route name shall be followed by the word "between," or in some cases "at". However, if the device is located in an end-of-block segment, cardinal direction references such as "north of," "south of," "east of," or "west of" shall be used. The reference street names following the word "between" shall be listed in numeric-alpha order.

Examples which illustrate the above are shown below:

1. "Main Street between 1st Street and Temple Street" uses the route name, the word "between" and the reference street names listed in numeric-alpha order.
2. "Pacific Avenue south of Shepard Street" incorporates the cardinal direction reference since the street terminates.

- Jogged Streets

Where a street has a jog at an intersecting cross street and each leg of the jogged street is signalized and operated by a separate controller, it is necessary to have a distinct name for each intersection. This may necessitate reference to the adjacent cross street external to the jogged segment which generally parallels the jogged street. When this is necessary, the name of the intersection should be appended by the word "near" followed by the adjacent parallel street external to the jogged segment.

Examples which illustrate the above are described below:

1. "Foothill Boulevard and Osborne Street near Clybourn Avenue" and "Foothill Boulevard and Osborne Street near Terra Bella Street" are thusly named to distinguish them.

Department of Transportation MANUAL OF POLICIES & PROCEDURES	SUBJECT Traffic Signal Design Guidelines	SECTION 521	DATE 9/2010	Page 11
---	---	----------------	----------------	------------

2. “Franklin Avenue and Highland Avenue” and “Franklin Avenue, Franklin Place and Highland Avenue” do not require appending with the word “near” since they already have distinct names.

- Duplicated Names

Duplicated street names that are not the result of a jog also need to be given distinct names. Usually, name duplication occurs at or near the boundary of adjacent cities or in outlying communities that annexed to the City of Los Angeles. In order to provide a distinct name, the associated adjacent city or community should be cited in parentheses after the duplicated street name.

Examples which illustrate the above are described below:

1. “Imperial Highway and Main Street (Los Angeles)” located in the southern part of the City versus “Imperial Highway and Main Street (El Segundo)” near the airport.
2. “9th Street and Western Avenue (Koreatown)” versus “9th Street and Western Avenue (San Pedro).”
3. “San Diego Freeway Northbound Off-Ramp and Sepulveda Boulevard (Bel Air)” versus “San Diego Freeway Northbound Off-Ramp and Sepulveda Boulevard (Mission Hills).”

Interjurisdictional Agreements

There shall be a maintenance and/or operational agreement for each traffic signalized intersection that lies partially within another jurisdiction, lies completely within another jurisdiction but is maintained and/or operated by LADOT or lies completely within the City of Los Angeles but is maintained and/or operated by another agency. The maintenance and/or operational agreement shall define the cost sharing among the jurisdictions. The agreed cost-sharing percentages shall be shown on the signal plan for that intersection. If the cost sharing for a particular project is to be different, it is to be so specified on the plan.

Design Elements

The LADOT Special Provisions and Standard Drawings for the Installation and Modification of Traffic Signals shows some of the special hardware used.

- Signal Standard Locations

Department of Transportation MANUAL OF POLICIES & PROCEDURES	SUBJECT Traffic Signal Design Guidelines	SECTION 521	DATE 9/2010	Page 12
---	---	----------------	----------------	------------

The precise location of traffic signal standards relative to curb faces and crosswalks are shown in S-51.0. However, below-ground utilities and structures may require adjustments to these locations.

- Warning Beacons

Typical layouts and operations for Fire Station Warning Beacons and Activated Pedestrian Warning Devices are shown in S-60.0 and S-55.0 respectively.

- Mastarm Signals

Mastarm signals are required where an approach has two or more striped lanes or a significant right offset. The criteria are shown in S-102.0. Farside mastarm signal heads generally are to be placed as close as practical to the extension of the middle of the number two, number one or left-turn lane, depending on the type of left-turn phasing. Where a mastarm signal is otherwise required facing a terminating street, such as a "T" or offset intersection, a high mount (Type 1A) standard may be used instead, as shown in S-101.0, if the street upon which it is placed is fully developed. Nearside supplemental mastarm signal head to be installed when the mastarm head is outside of a 20-degree half cone-of-vision. The locations are shown in S-65.0.

- Pedestrian Control

Pedestrian heads shall be provided wherever pedestrians are legally allowed to cross. Otherwise, pedestrian prohibition signs mounted on barrier railing are to be installed.

On divided streets where there is sufficient pedestrian clearance time to allow pedestrians to cross in one phase, median pedestrian heads shall not be provided.

On divided streets where it is not feasible to allow pedestrians to cross in one phase, pedestrians may be required to wait in a raised median area. This applies where the median island is at least 20 feet in width, it extends across the marked crosswalk and the waiting area is raised. In such cases, pedestrian heads in the median island are required. In addition, the crosswalks across each roadway should be offset or aligned to create an angle point at the median island so as to provide a visual cue of the need to wait in the median.

Pedestrian push buttons are to be located within 5 feet of the outside crosswalk line, as shown in S-101.0.

Department of Transportation MANUAL OF POLICIES & PROCEDURES	SUBJECT Traffic Signal Design Guidelines	SECTION 521	DATE 9/2010	Page 13
---	---	----------------	----------------	------------

For projects involving new traffic signals or major traffic signal reconstruction accessible pedestrian features shall be provided.

- Typical Traffic Signal Layouts

Typical traffic signal layouts for locations involving three legs, four legs, one-way streets, left-turn phasing, driveways and midblock crosswalks are shown in S-101.0. The typical layouts assume that the criteria for mastarm signals are met.

- 12-Inch Signal Heads

LADOT criteria for 12-inch signal heads exceed State and national standards. Twelve-inch heads generally are required, as summarized in S-103.0.

- Detectors

Limit line inductive loop detectors are to be located as shown in S-70.0 for single lane and multiple lane approaches. On all actuated approaches, new or reinstalled detection shall be capable of detecting bicycles.

Inductive loop detectors can be used in a variety of special applications. S-75.0 shows these applications. Other detection technologies may be used, as justified, in place of inductive loop detection.

System detection identifies volume and occupancy and is used to determine system timing parameters. It may also be used for traffic counting stations and for advance detection.

Advance detection is used on actuated approaches, where speed limits or 85th percentile speeds are 40 miles-per-hour and above. It is used to call and extend the green so that platoons generally will not have to stop and is located so that a vehicle just upstream of the detector when the yellow is displayed can comfortably decelerate to a stop.

Left-turn queue detection is used to call and sometimes extend a protected left-turn phase, when a queue develops. It can be used for transit assistance.

Bus queue jumper detection is used to call and extend a leading bus phase.

Small bicycle detection is used in bike lanes.

Department of Transportation MANUAL OF POLICIES & PROCEDURES	SUBJECT Traffic Signal Design Guidelines	SECTION 521	DATE 9/2010	Page 14
---	---	----------------	----------------	------------

Rest-in-red detection is used to encourage motorists to decelerate to a more appropriate speed, where there is a documented collision pattern involving excessive speed near the intersection and an adequate trial of appropriate warning devices has not been successful.

- Visibility-Limited Traffic Signal Heads

Visibility of traffic signal heads is to be limited using programmed visibility heads, beveled visors or long visors, as shown in S-85.0.

Longitudinal visibility generally should be limited where adjacent signals are within 300 feet or where slot clearance is to be provided at an offset intersection. The longest ground cut-off feasible should be used, so as to maximize visibility once motorists discharge from the upstream signal. Usually a curb line prolongation is used for the ground cut-off. The yellow lens is not masked to ensure that drivers of buses and tall trucks may see the change interval in time to safely decelerate to a stop.

Lateral visibility generally should be limited so that no more than 50% of the lens width can be seen by motorists anywhere along the stop line of a conflicting approach. Right, left and long (a combination of right and left) visors are to be used in preference to programmed visibility heads, except where they cannot meet the 50% threshold criteria.

- Signalized Jogged Intersections

The design of signalized jogged intersections is a most complex task. Motorists can face the following challenges from one or more of the four approaches to a signalized jogged intersection:

1. Pedestrians might not be seen early on
2. Opposing vehicles might not be seen early on
3. Opposing left turns interlock
4. Reverse turn maneuver versus a single turn cannot readily be distinguished
5. Motorists must determine if there is one versus two intersections and how to respond to each

These challenges can be mitigated by providing a full complement of controls and applying them in a uniform manner. S-100.0 shows the options available for a variety of conditions. A primary consideration is whether or not to provide interior limit lines, so as to create two intersections. If the internal storage is 40 feet or more, then interior limit lines are to be provided. Another primary consideration is whether or not to provide opposed phasing for the jogged approaches, due to the challenges resulting from the physical separation. If opposing motorists

Department of Transportation MANUAL OF POLICIES & PROCEDURES	SUBJECT Traffic Signal Design Guidelines	SECTION 521	DATE 9/2010	Page 15
---	---	----------------	----------------	------------

are separated by more than 20 degrees, then some type of exclusive phasing is to be provided. The placement of signal heads is determined from the above considerations and the specific geometrics of the intersection.

- Left-Turn Phasing

LADOT guidelines for left-turn phasing have specific threshold values for protected, protected/permitted and opposed phasing. The guidelines are summarized in Table 1. The Signal Design Section or the ATSAC Design Section is responsible for checking with the Signal Timing Section to assure that a guideline has been satisfied before proceeding with the design.

- Right-Turn Phasing

Exclusive right-turn phasing generally should be provided where there is an exclusive right-turn lane in combination with complementary left-turn phasing or where high pedestrian volume in combination with right-turn vehicular demand results in excessive delay. Exclusive right-turn phasing should not be provided without an exclusive right-turn lane. Where complementary left and right-turn phasing exists, U-turns shall be prohibited for the approach which receives the left turn phase. Where the crosswalk that is crossed by the right turn has high pedestrian volumes, the right turn phase should be a lag phase.

- Interconnect

Traffic signals within 2000 feet of each other should be interconnected. Those that are 2000 to 3000 feet apart should be evaluated as to the need for interconnect, based on link volume. Signals that are greater than 3000 feet apart need not be interconnected. All signals in an ATSAC system shall be interconnected.

- Controllers

All signalized intersections maintained by LADOT shall use LADOT-compatible Type 170 or Model 2070 controllers.

- Electric and Variable Message Signs

Appropriate application of electric and variable message signs are encouraged as ways of providing credible, real-time information to motorists of real-time traffic conditions.

Department of Transportation MANUAL OF POLICIES & PROCEDURES	SUBJECT Traffic Signal Design Guidelines	SECTION 521	DATE 9/2010	Page 16
---	---	----------------	----------------	------------

- Freeway Guide Signs

Freeway guide signs generally fall into two categories -- “lane assignment” and “action.”

Due to the various types of on-ramp configurations, some freeways can be entered from the right lane while others can be entered from the left lane on a cross street. Accordingly, multi-lane streets having access to freeways shall be posted with “lane assignment” signs. “Action” freeway guide signs are an essential follow-up to “lane assignment” signs.

Generally, overhead signing is the most effective means of communicating freeway access to motorists. Roadside guide signing on the right or in a raised median can be used where overhead signing is not immediately feasible. However, roadside guide signing has limited area for text and may require more signs for communicating lane assignment. S-476.1 shows the maximum sign area that may be installed for various postings.

The various formats for freeway guide signing are shown in S-418.5 and S-418.6.

- Overhead Signs

Overhead signs provide a high degree of visibility to forewarn and direct motorists on multi-lane approaches of access or lane assignment conditions that generally cannot be anticipated by unfamiliar motorists. Conditions include: divergent arterial roadways; skewed arterial approaches; unshadowed left-turn lanes; arterial grade separations, including freeways; bus and/or carpool lanes; street name or sign route changes; and end of one-way operation. These situations are illustrated in S-418.6. Overhead signs should be placed no more than 30 feet downstream from a modern electrolier. If this is not feasible, then external illumination should be incorporated into the design of the overhead sign.

- Large Street-Name Signs

At signalized intersections supplemental large street-name signs are to be posted as per S-486.0 and mounted per S-457.1. At signalized intersections with one-way streets the large supplemental street name signs are to be further supplemented with large R-10 (One-Way) signs as shown in S-473.0.

Table 1. Summary of LADOT Left-Turn Phasing Guidelines			
Phasing	Overhead Position	Factor	Threshold Values and Criteria
Protected (usually lead; lag OK if no opposing permitted left turns)	A three-section arrow head over middle of left-turn lane(s), plus a three-section head over middle of number two lane (second lane from center).	Accidents	Four left-turn accidents in a recent 12-month period during various time periods or 3 or more for 3 consecutive years. Four right angle or four left-turn accidents in a recent 12-month period at one of the intersections involving vehicles departing from the interior limit line of a left offset intersection, so as to allow slot clearance.
		Geometry	Dual left-turn lanes across opposing traffic are feasible and desirable. Sight distance less than 5.5 sec. to number one opposing lane, plus 0.5 sec. to each additional opposing through lane Left-turn lane is inadequately shadowed on opposite leg (less than 9 ft. where turn is initiated). <ul style="list-style-type: none"> • Opposing left-turn paths on arterial street interlock. • Combination of wide intersection, higher speeds and failed cycles.
		Livable Neighborhoods	To be selectively applied to restrict left-turn capacity into a residential area, where there is a documented problem of significant through traffic using a residentially developed local or collector street.
Protected/ Permitted	A five-section cluster head over middle of number one lane (next to median or centerline), or a four-section head with a Red Arrow, Solid Yellow Arrow, Flashing Yellow Arrow, and Green Arrow over the middle of the left turn lane.	Capacity	Projected volumes: HCM, Chapter 9, Operational Analysis, documents inadequate capacity using optimized timing.
		Delay	Eighty percent or more of cycles fail for left turns, and opposing traffic would have an average delay of 40 sec. or less for any two hours. The delay threshold may be waived if there are no feasible alternate left-turn opportunities in a limited arterial street network.
		Lane Blockage	Queues recurrently spill over into number one lane and pocket cannot be extended.
		Peak Period Accidents	Three left-turn accidents in a recent 12-month period during peak traffic periods.
		Railroad Preemption	Left-turn vehicles queue across tracks and have difficulty clearing them before gate descends.
		Transit Reliability	Three cycles per hour fail for left-turning buses and opposing traffic would have an average delay of 40 sec. or less for any two hours.
		Alternate Route	The left turn would facilitate travel along a primary emergency route or freeway alternate route.
		Livable Neighborhoods	To be selectively applied to increase left-turn capacity onto the arterial street network and away from a residential area, where there is a documented problem of significant through traffic using a residentially developed local of collector street.

Table 1. Summary of LADOT Left-Turn Phasing Guidelines			
Protected/ Permitted	A four-section stacked head over middle of number one lane, or a four-section head with a Red Arrow, Solid Yellow Arrow, Flashing Yellow Arrow and Green Arrow over the middle of the left turn lane.	(See Protected/ Permitted factors)	Same as for Protected/Permitted criteria but restricted to locations where a permitted left-turn is not allowed in the opposing direction.
Opposed	A four-section, stacked head over middle of number one lane.	Lane Groups	Intersection operation can be improved by having separate phasing for opposing directions, often to allow a left-through optional lane.
		Offset Legs	Opposing legs of a single intersection have a significant offset.
Permitted	A three-section head over middle of number two lane.	Default Operation	Where none of the above is met.

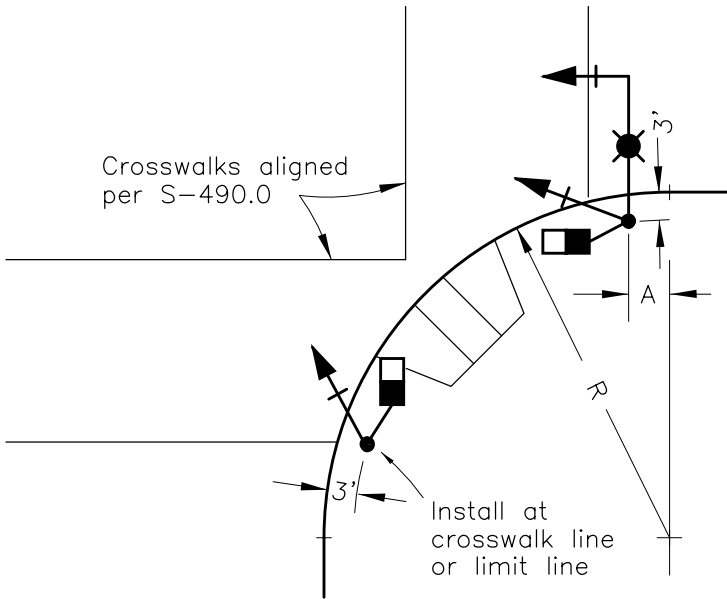

R	A *
50'	20'
45'	17'
40'	13'
35'	10'
30'	6'
25'	2'
20'	0'
15'	0'

* Adjust distance A so that any pedestrian pushbutton is within 5' of crosswalk line. If this is not feasible, then a Type 7 pole is to be used.

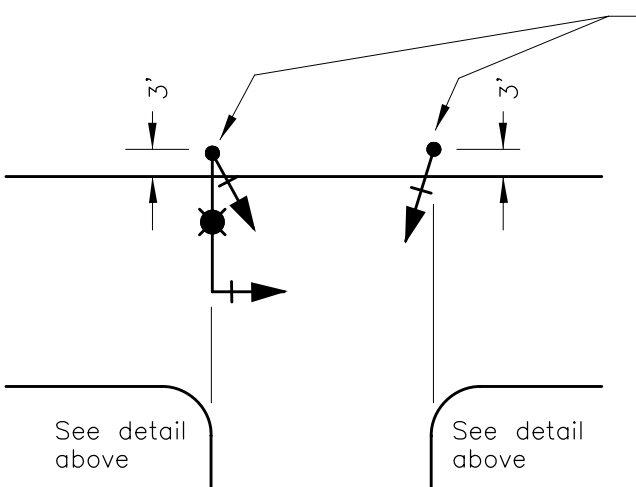
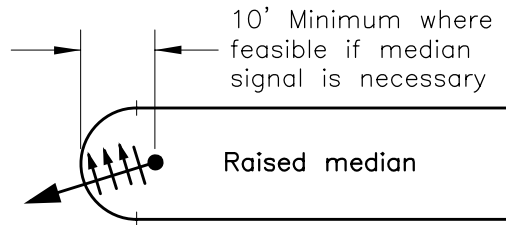

Generally; install along the curb face prolongation. The locations may be adjusted to satisfy cone-of-visibility requirements, to avoid below-ground obstructions, or to ensure that any pedestrian pushbutton is within 5' of the crosswalk line. If the selected pole location is not within 5' of the crosswalk line, then a Type 7 pole is to be provided for a pedestrian pushbutton. Mastarm locations should be a minimum of 50' downstream of the approach stop line. When this is not feasible, a shorter distance consistent with the requirements of the MUTCD, Section 4D.15, may be used.

Note: For these and other intersection alignments not depicted above, the distance between the center of the pole to the curb face shall be 3', unless otherwise shown on plan.

DWN	MT	01-23-02	Title Typical Location of Traffic Signal Standards	1/1
CKD				
T. E.				
Sr. T. E.	TLJ	01-29-02	CITY OF LOS ANGELES DEPARTMENT OF TRANSPORTATION	
Pr. T. E.	GO	01-30-02		
Approved		<i>John E. Fisher</i>		Drawing No.
for		Frances T. Banerjee, General Manager		S-51.0

Flashing beacon
activated by pedestrian push button

Notes:

1. The flash pattern utilizes LED heads and a Model 2070 controller. There are 60 flash periods per minute. The flash period for each beacon includes three pulses within 0.5 seconds and a pause of 0.5 seconds. The pulses of one beacon alternate with the pause of the other beacon, as shown below.
2. Flash length is $\frac{W}{3.5}$ seconds and retimes with each call.
3. See S-481.0 for required advance signing, pavement marking, and red curb.
4. At school crossings, school related signs and pavement markings shall be used in place of those shown hereon, as per S-481.0.

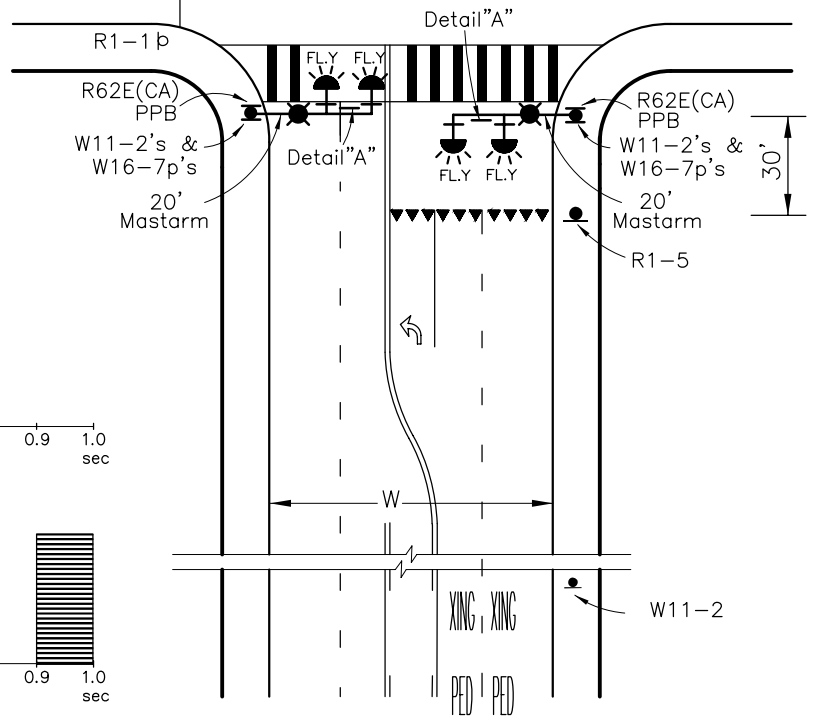
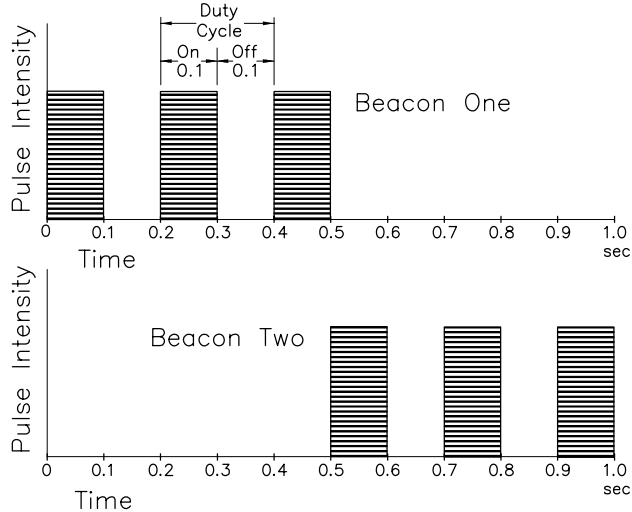
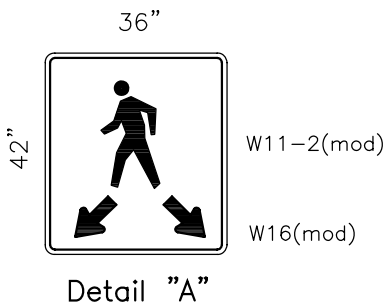
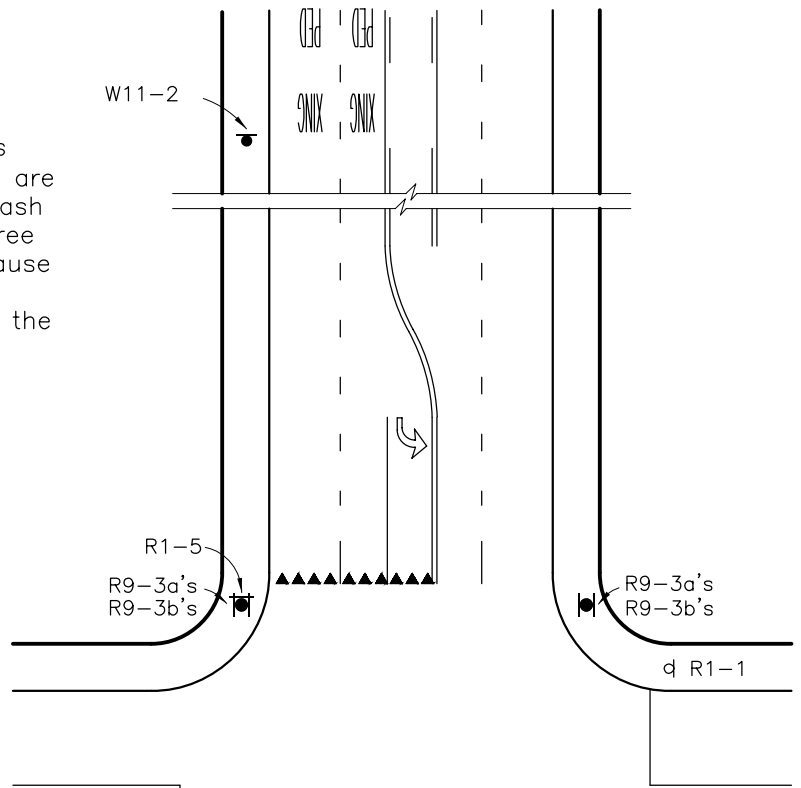

DWN	EC	6-10-10	Title Typical Layout for Activated Pedestrian Warning Device	1/1
CKD				
T. E.				
Sr. T. E.				
Pr. T. E.			CITY OF LOS ANGELES DEPARTMENT OF TRANSPORTATION	
Approved June 24, 2010			Drawing No.	
<i>John E. Fisher</i>			S-55.0	
for Rita L. Robinson, General Manager				

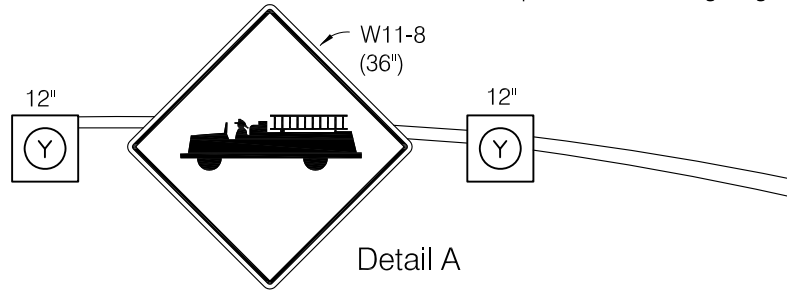
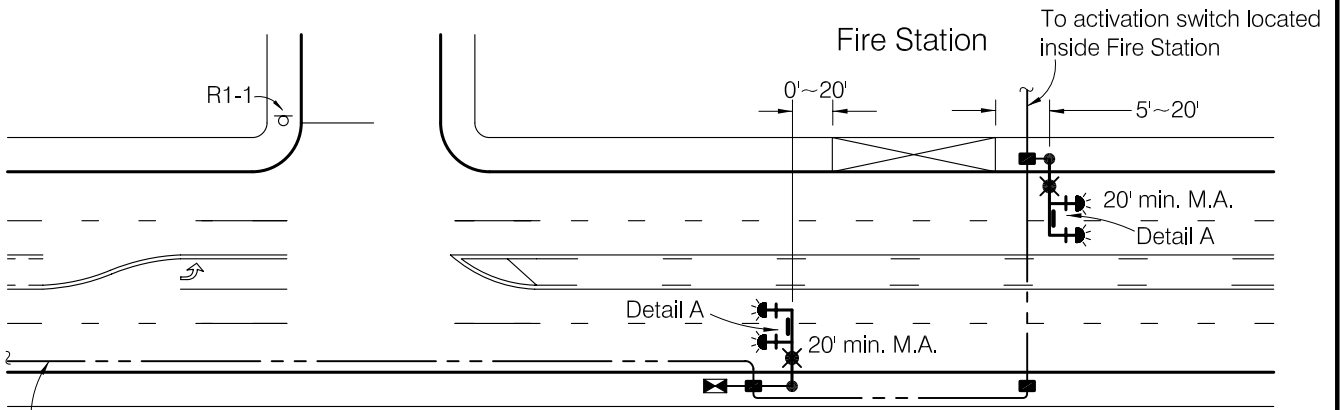

Authorization

Fire Station Warning Beacons shown on this plan are authorized when:

1. There are existing warning beacons that flash all-day or during non-emergency periods and it is desired to retain some form of warning beacons; or
2. There are no existing warning beacons, the Fire Station Captain requests or concurs with the installation of Fire Station Warning Beacons, and an engineering study using LADOT guidelines documents Condition A, B, C or D below:
 - A. An accident pattern involving emergency vehicles at or near the fire station driveway.
 - B. The cross traffic visibility between the emergency vehicle driver and arterial street motorists is less than an acceptable gap.
 - C. The queue extending from a nearby signal recurrently blocks the fire station driveway and "KEEP CLEAR" pavement markings have not been effective.
 - D. There is an excess of 30 seconds of delay for exiting emergency vehicles.

Operation

1. The beacons are dark in the absence of a manual emergency response activation.
2. Upon an emergency response, a station officer manually activates a switch to commence flashing of the yellow beacons. The beacons immediately flash alternately in push/pull fashion. The duration of emergency flashing operation generally is 45 seconds. The warning signs and flashing beacons complement Section 21806 of the California Vehicle Code, regarding driver and pedestrian responsibilities near authorized emergency vehicles. They serve to alert motorists when an emergency is in effect and where emergency vehicles will be entering the street.
3. If Condition C is satisfied or if there is an adjacent traffic signal within 300 feet, then it should operate under preemption operation. This preemption operation will hold vehicles from approaching the fire station in one direction, allow queued vehicles to clear the driveway in the opposite direction and enable emergency vehicles to clear the intersection. The operation is as follows:
 The phase receiving the green goes to normal pedestrian and yellow clearances followed by 3 seconds of all-red for all approaches with an opposing, permissive left-turn, in order to preclude a left-turn trap situation. Then the approach to the adjacent signalized intersection, which is on the departure from the Fire Station, goes to green and stays in green. All other vehicle approaches stay in red and pedestrian indications provide a solid Upraised Hand (Don't Walk) display.
4. At the end of emergency preemption, normal signal operation resumes from the current position. Flashing yellow beacons are extinguished.

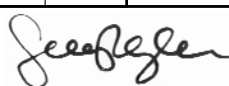
DWN	MT	9-30-15	Title Fire Station Warning Beacons 1/1
CKD			
T. E.	JV	9-30-15	
Sr. T. E.	MA	10-1-15	
Pr. T. E.	VJ	10-2-15	
CITY OF LOS ANGELES DEPARTMENT OF TRANSPORTATION			
Approved  Seleta Reynolds, General Manager		11-20-15	Drawing No. S-60.0

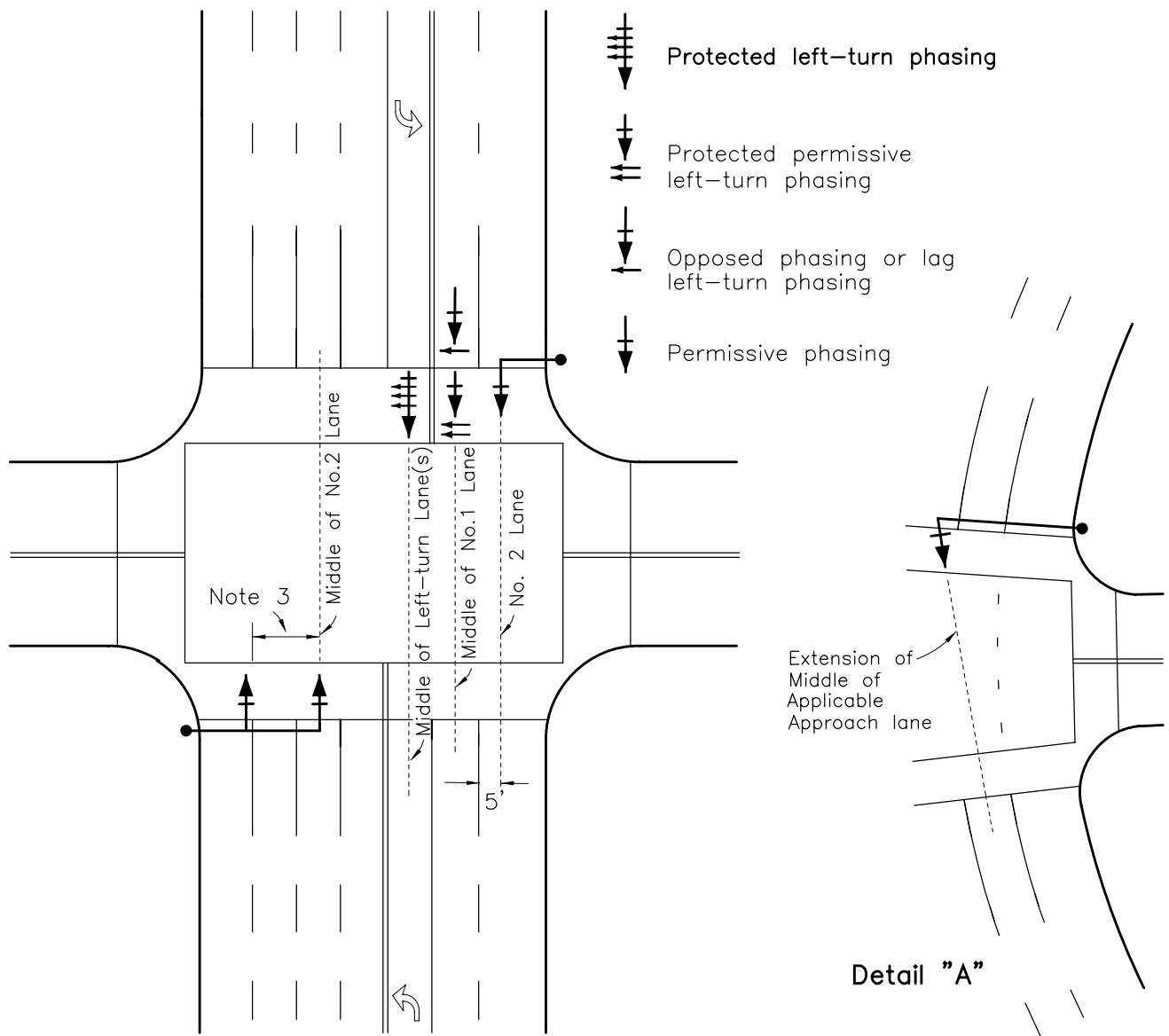

Notes:

1. For new construction, the mastarm length should be selected so that the head locations are within 3 feet of the locations shown above. Curved alignments should locate the mastarm head within 3 feet of the tangent to the center of the respective approach lane at stop line (see Detail A). Where street trees or other obstructions interfere with signal head visibility, the mastarm signal head location should be extended to provide adequate visibility.
2. For existing traffic signals where there is a project involving special funding, mastarm lengths should be changed to ensure that they meet the criteria in Note 1.
3. Where an approach has 4 or more through and right turn lanes, a second mastarm signal head should be placed 15 feet to the right.

DWN	MT	12-05-05	Title	MASTARM SIGNAL HEAD PLACEMENT
CKD				
T. E.				
Sr. T. E.			CITY OF LOS ANGELES DEPARTMENT OF TRANSPORTATION	
Pr. T. E.	SS	1-25-06		
Approved		January 30, 2006		Drawing No.
		for Frances T. Banerjee, Interim General Manager		S-65.0

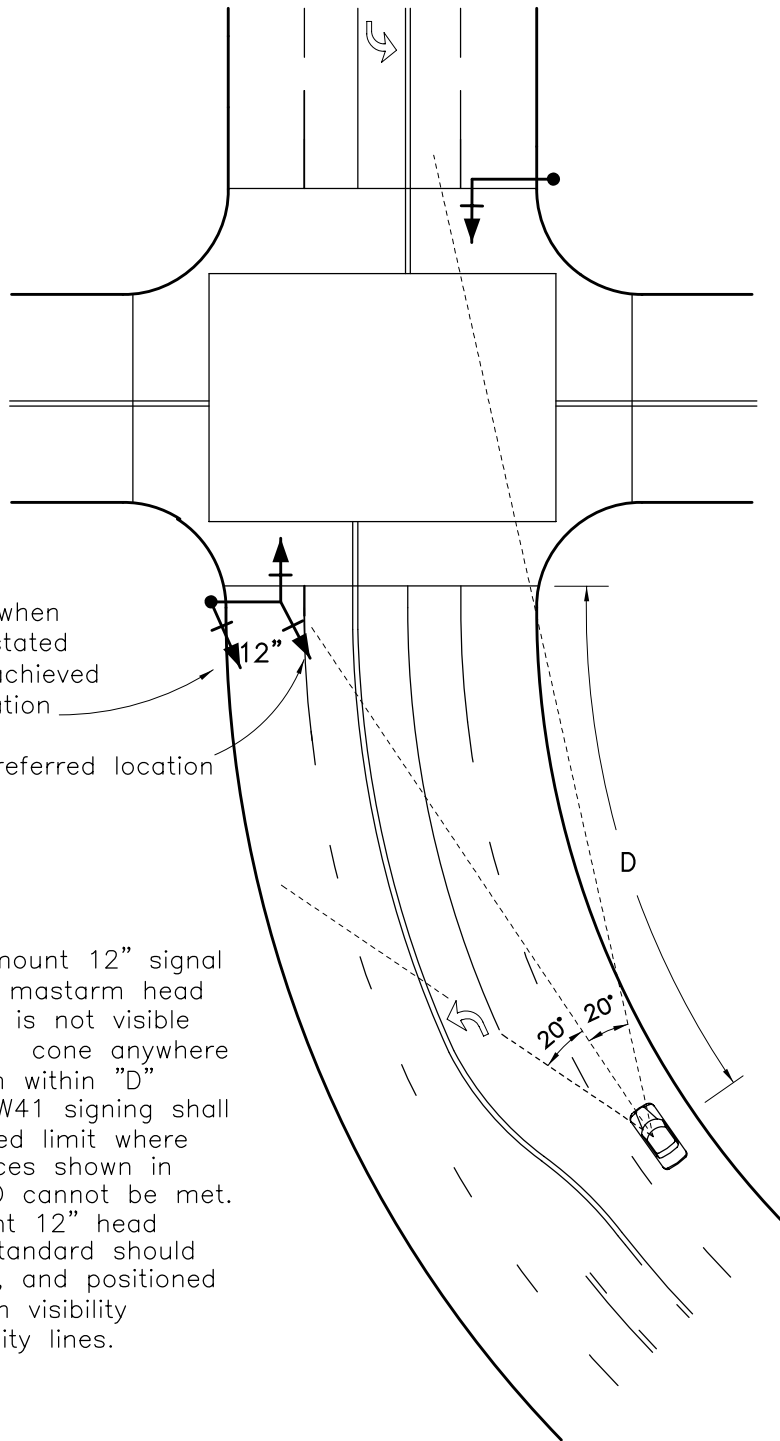

Alternate location when visibility distance stated below cannot be achieved with preferred location

preferred location

Provide a nearside highmount 12" signal head to supplement the mastarm head when the mastarm head is not visible or is outside of the 20° cone anywhere along a curved approach within "D" as shown in the table. W41 signing shall be installed for any speed limit where minimum visibility distances shown in Table 4-1 of the MUTCD cannot be met. Clearance to a highmount 12" head mounted on a vertical standard should be between 14' and 18', and positioned to avoid interference with visibility obstructions such as utility lines.

Speed Limit mph	D ft
25	215
30	270
35	325
40	390
45	460
50	540
55	625

Curved Approach Criteria

For single lane approaches, The number of pairs of loop detectors is based on distance A measured between the double yellow center line (DYCL) and the curb face. A single pair shall be used for distance A less than 20'. Dual pairs shall be used for distance A greater than or equal to 20'. Loop detectors should be installed as specified in the tables below.

Case A: Single Pair

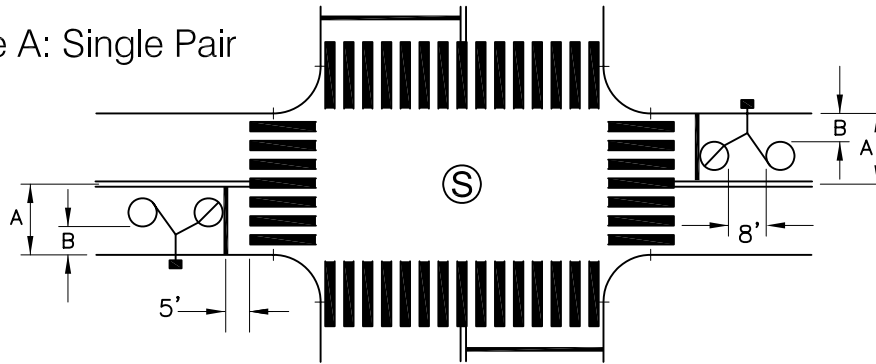

Dist. Bet. DYCL and Curb Face (A)	Dist. Bet. Inner Loop and Curb Face (B)	Dist. Bet. DYCL and Curb Face (A)	Dist. Bet. Inner Loop and Curb Face (B)
10'	3'	15'	6'
11'	3'	16'	6'
12'	3'	17'	7'
13'	4'	18'	8'
14'	5'	19'	8'

Case B: Dual Pair

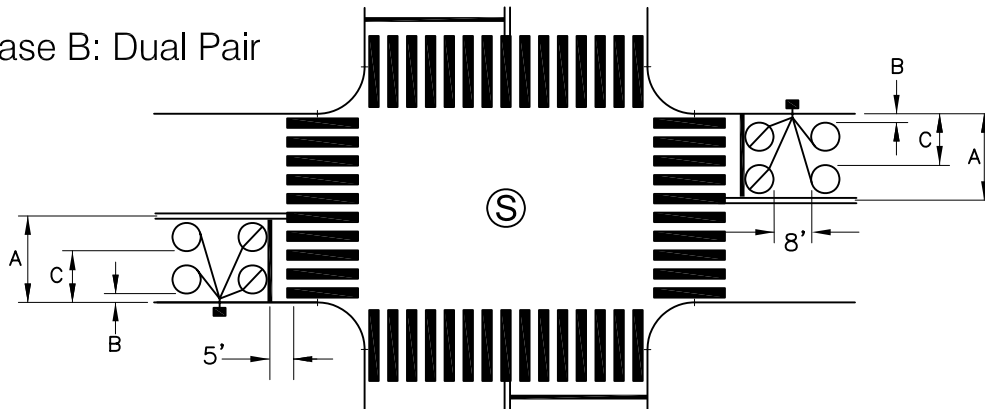

Dist. Bet. DYCL and Curb Face (A)	Dist. Bet. Inner Loop and Curb Face (B)	Dist. Bet. Outer Loop and Curb Face (C)
20'	3'	12'
21'	3'	12'
22'	3'	13'
23'	3'	13'
24'	4'	14'
25'	5'	15'

Single Lane Approaches

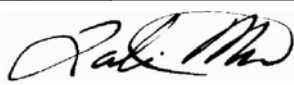
DWN	MT	3-15-13	Title LIMIT LINE INDUCTIVE LOOP DETECTOR PLACEMENT (1/2)
CKD			
T. E.			
Sr. T. E.	MA	3-19-13	CITY OF LOS ANGELES DEPARTMENT OF TRANSPORTATION
Pr. T. E.	VJ	3-20-13	
Approved  Jaime de la Vega, General Manager			Drawing No. S-70.0

For multiple lane approaches, loop detectors should be centered in lanes.
 For curb lane, follow the guidelines for single lane approach.

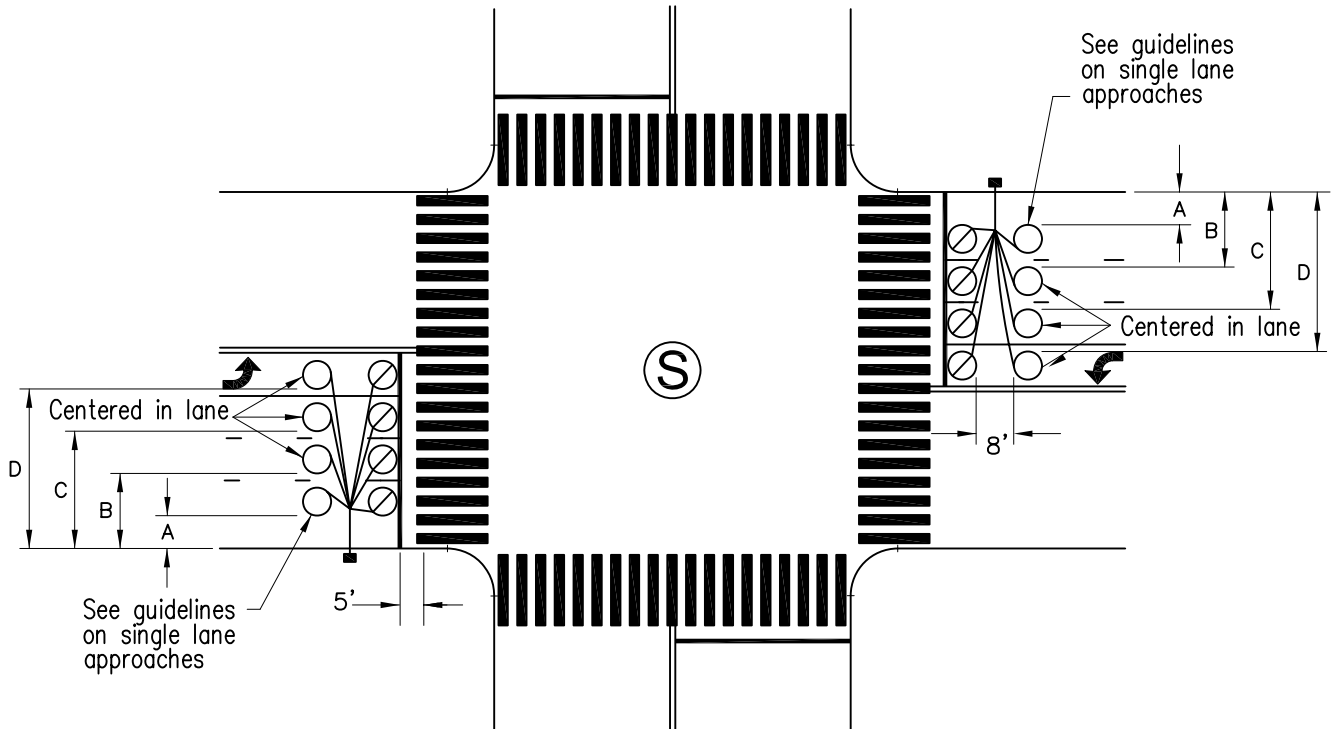

Multiple Lane Approaches

Notes:

1. This Standard Drawing applies to new installations and re-installations due to maintenance. Loop detectors should be re-installed at existing locations where the loop detectors extend 4' or more into marked crosswalks and limit lines.
2. All loops are 6' diameter with 8' separation between front and rear loops.
3. A, B, C, D dimensions shall be shown on plans.
4. The loop detectors adjacent to the limit line shall be bicycle detectors.
5. See Standard Drawing Nos. S-70.1A and S-70.1D for installation details.
6. Types and locations of conduits, pullboxes and stub-outs to be installed per plan.

Ped-Actuated Pedestrian Crossing

(Pushbutton activates accessible pedestrian signals and the WALK interval)

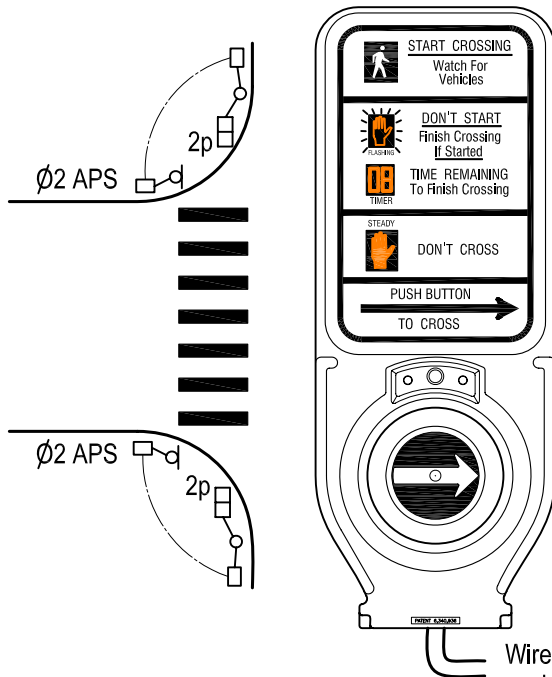

Wires to controller pedestrian pushbutton (PPB) input

Pre-Timed & Rest-in-Walk Pedestrian Crossing

(Pushbutton activates accessible pedestrian signals only. WALK interval is on recall)

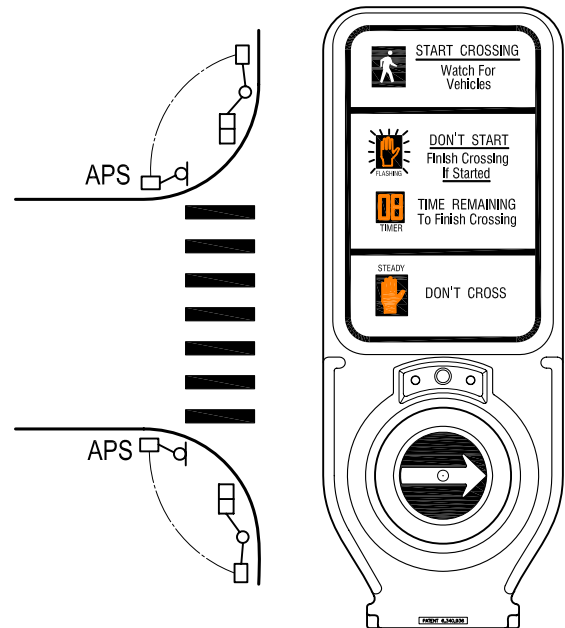

No wires connected to controller pedestrian pushbutton (PPB) input

Notes:

1. APS shall be used for situations where new pedestrian pushbuttons are being installed or where they are being replaced, due to maintenance.
2. Audio Specifications:
 - WALK interval
 - Rapid "Tick" tone is activated with a duration of 0.15 seconds and repeats at 0.25-second intervals for a maximum of 7 seconds. Then, APS returns to locator tone for the remainder of the WALK interval.
 - FLASHING DON'T WALK interval and SOLID DON'T WALK interval
 - Locator tone shall have a duration of 0.15 seconds and repeat at 1-second intervals.
3. Vibrotactile Specifications:
 - Pushbutton vibrates only during the first 7 seconds of the WALK interval.
 - Tactile arrows shall be aligned parallel to the direction of travel on the associated crosswalk.
 - WALK tones and vibrotactile require actuation, even at pre-timed crossings.
4. See California MUTCD 2014, Figures 4E-3 and 4E-4 for pushbutton locations.
5. Countdown pedestrian heads shall be installed at all accessible pedestrian signal locations.
6. See sheet 2/2 for accessible pedestrian signal field wiring for ped-actuated pedestrian crossing.
7. Low Voltage "Grey Cable" on sheet 2/2 refers to manufacturer supplied cable that is included with the APS unit.
8. 4cc on sheet 2/2 as per LADOT Spec. 92-097-01

DWN	MT	6-27-16	Title ACCESSIBLE PEDESTRIAN SIGNAL (APS) 1/2	
CKD				
T. E.	JV	7-7-16		
Sr. T. E.	MA	8-3-16		
Pr. T. E.	VJ	8-9-16	CITY OF LOS ANGELES DEPARTMENT OF TRANSPORTATION	
Approved			8-9-16	Drawing No.
 Seleta J. Reynolds, General Manager				S-73.2

APS pushbutton and associated pedestrian head on same pole for ped-actuated pedestrian crossing

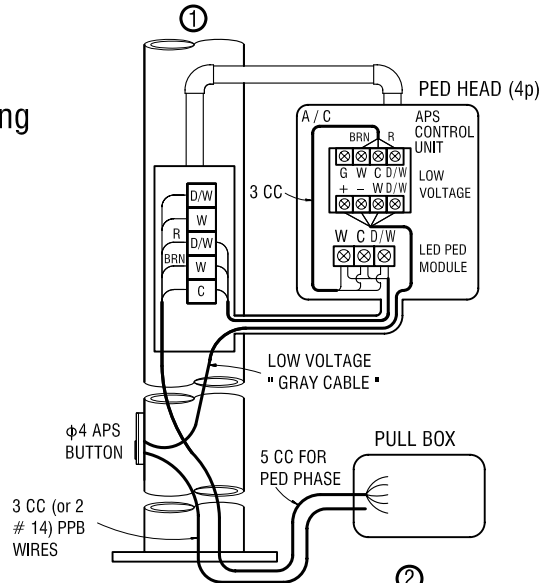
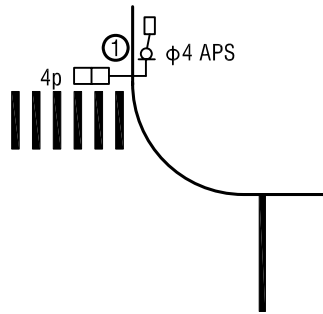

APS pushbutton and associated pedestrian head not on same pole for ped-actuated pedestrian crossing

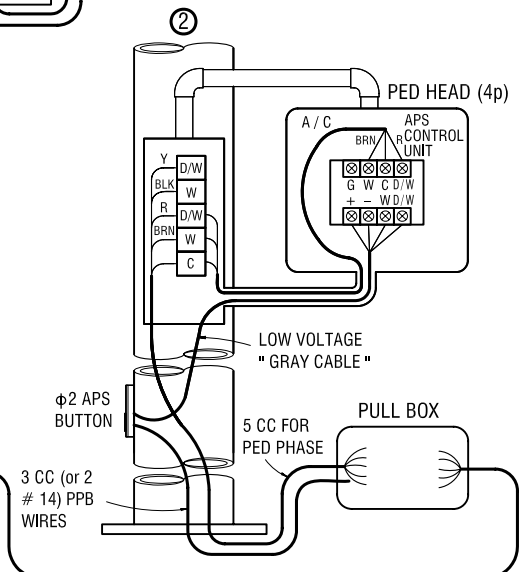
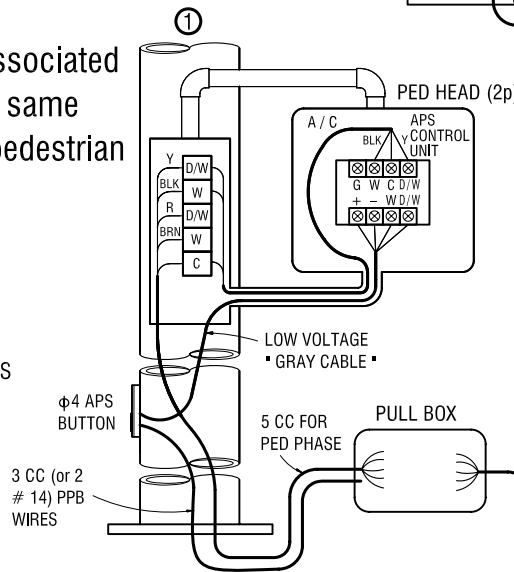
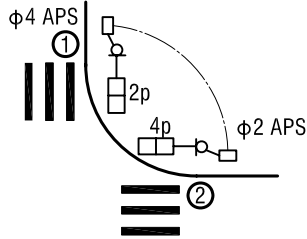

SPARES (5 CC IF NO SPARES)

APS pushbutton on Type 7 post and associated pedestrian head not on same pole for ped-actuated pedestrian crossing

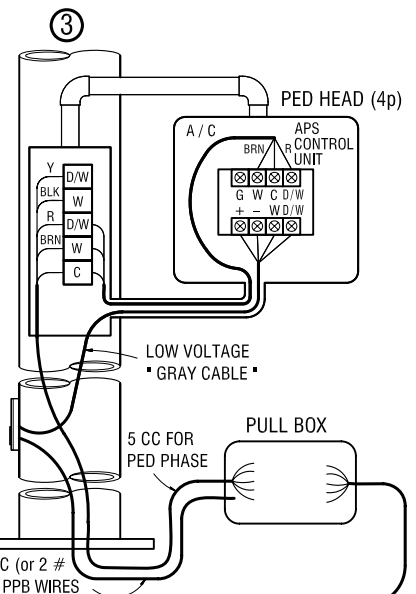
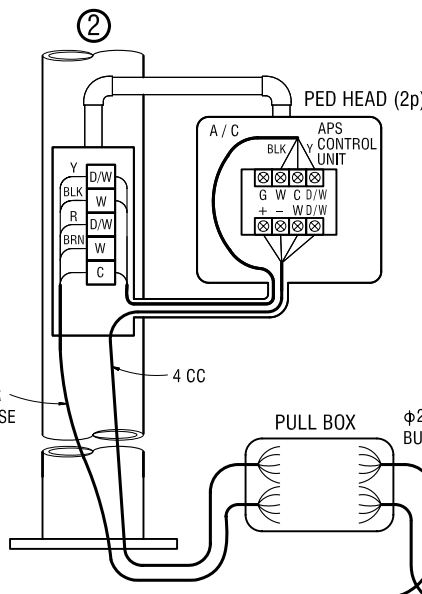
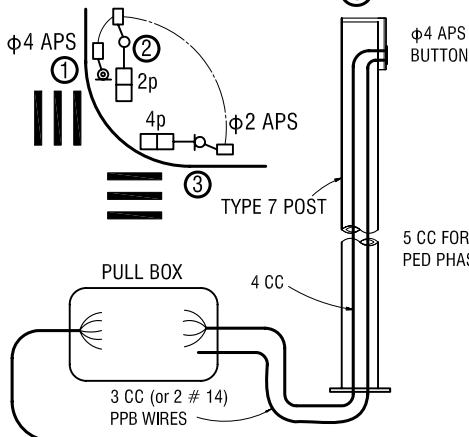

SPARES (5 CC IF NO SPARES)

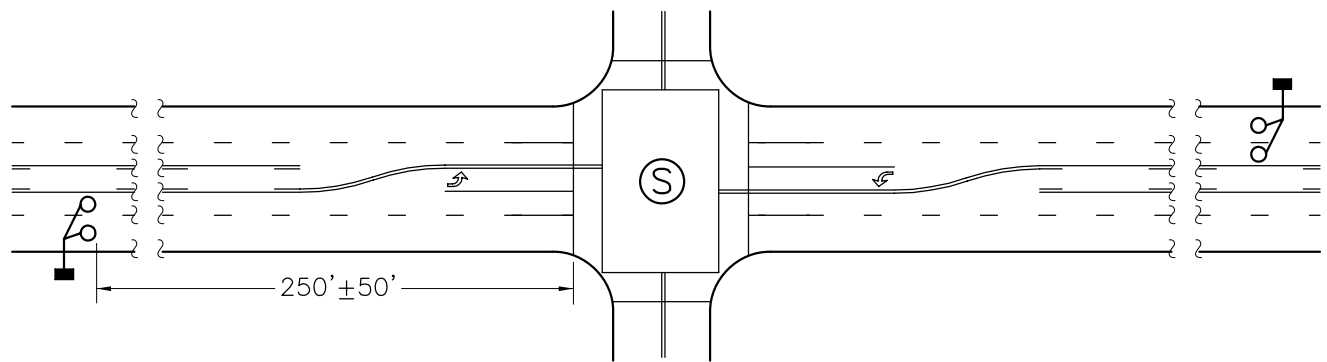

System Detection

Notes

1. System Detectors identify volume and occupancy and are used to determine the timing parameters in an automated signal system.
2. They are to be installed at 1/4 mile points or less and on all arterial street approaches. However, if an arterial street carries less than 8,000 ADT then system detection on the associated approaches may be deleted.
3. The precise locations are adjusted to avoid placement at cross streets, alleys, driveways, maintenance holes or vaults.

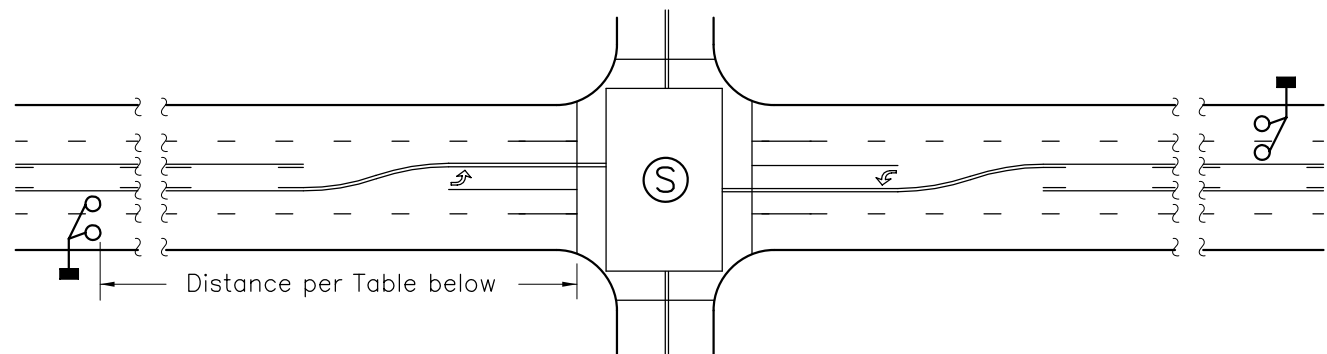

Advance Detection

Detector Setback Table

Speed Limit mi/hr	Minimum Distance ft
25	105
30	140
35	185
40	230
45	285
50	340
55	405

Notes

1. Advance Detectors are used to call and extend the green for higher speed arterial streets where the approach is actuated.
2. Generally, they are used in conjunction with limit line detection. However, on streets with all-day parking prohibitions and no side streets, alleys or driveways downstream of the advance detectors, limit line detection may be deleted. In this case the advance detectors can count arrivals on red and provide the appropriate initial green time.
3. They are located so that a vehicle just upstream of the detector that is displayed a yellow, due to a gap-out, max-out or force-off, can comfortably decelerate to a stop.
4. On actuated approaches they shall be used for speeds of 40 miles per hour and above and may be used for lower speeds.
5. Where appropriate, they can be adapted to also function as system detectors.

DWN	MT	2-24-09	Title Special Detector Applications	
CKD				
T. E.				
Sr. T. E.	JW	2-27-09	CITY OF LOS ANGELES DEPARTMENT OF TRANSPORTATION	
Pr. T. E.	SS	3-3-09		
Approved		March 3, 2009		Drawing No.
				S-75.0
for Rita L. Robinson, General Manager				

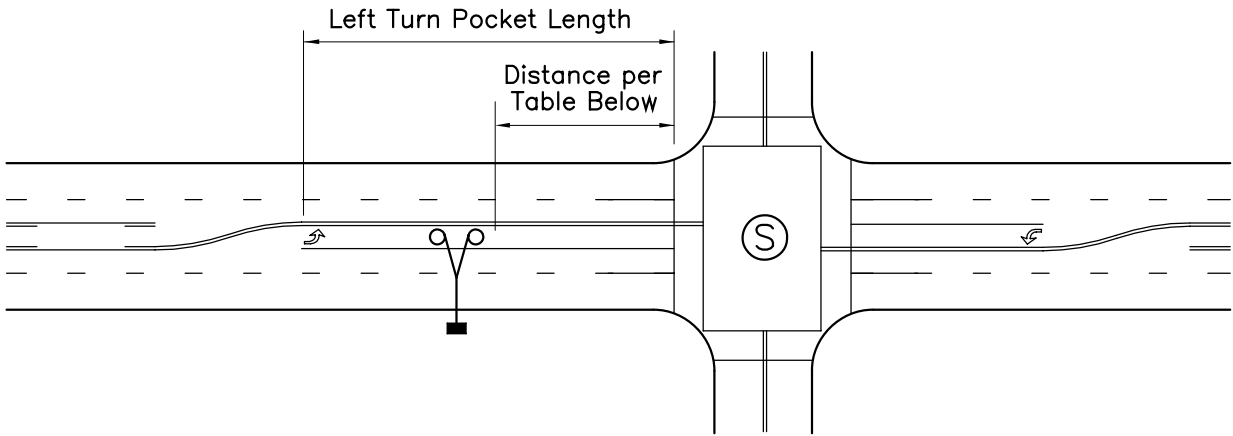

Left Turn Queue Detector

Notes

1. The Left Turn Queue Detector is used for protected-permissive left turn phasing to place a call and extend the protected phase only when a queue of sufficient length develops.
2. Two six-foot diameter circular loops with eight-foot spacing shall be used for queue detection.
3. Typically, three seconds of call delay should be used to distinguish a moving vehicle from a standing queue.
4. Lagging permissive-protected operation shall be utilized only where there is no opposing permissive left turn, because permissive left turners opposing a protected left turn could mistakenly believe that all through movement has been stopped.
5. The placement of the queue detector is based upon the left turn lane storage distance, the queued vehicle desired to be detected, and the left turn phase sequence, according to the table below. The fourth queued vehicle generally should be detected, which minimizes the need for phase actuations while tending to ensure a maximum of two cycles of delay for the second and third vehicles. Third vehicle detection should be considered where there is a high probability that left turn vehicles might block the adjacent through lane.
6. The left turn pocket should be lengthened, where feasible, to provide sufficient reserve storage to accommodate additional arriving vehicles after the detected vehicle places a call. To minimize the probability of vehicles blocking the adjacent through lane, the designated left turn vehicle should be detected for the associated pocket length shown in the table below. When the left turn lane is less than 110 feet, limit line detection without queue detection should be used for a leading phase, and a 20-foot setback should be used for a lagging phase.
7. If a queue detector is implemented where the adjacent approach lanes are actuated, limit line detection is also required to place a call for the through phase (permissive turn), in addition to queue detection for the left turn phase.
8. Where protected-permissive phasing has been authorized, based on documented bus delay, the queue detector should be placed upstream of the limit line, as shown in table. If a bus is the only vehicle, it will not place a call and will be able to turn during the permissive phase. If it is the second or third vehicle in the queue, the bus will place a call. If it is in the queue upstream of the detector, the preceding vehicles will place a call.

Detector Setback Table (feet)

Minimum Pocket Length	Detected Vehicle	Detector Setback	
		Leading Phase	Lagging Phase
110	Third	45	20
145	Fourth	70	35
110	Bus	55	25

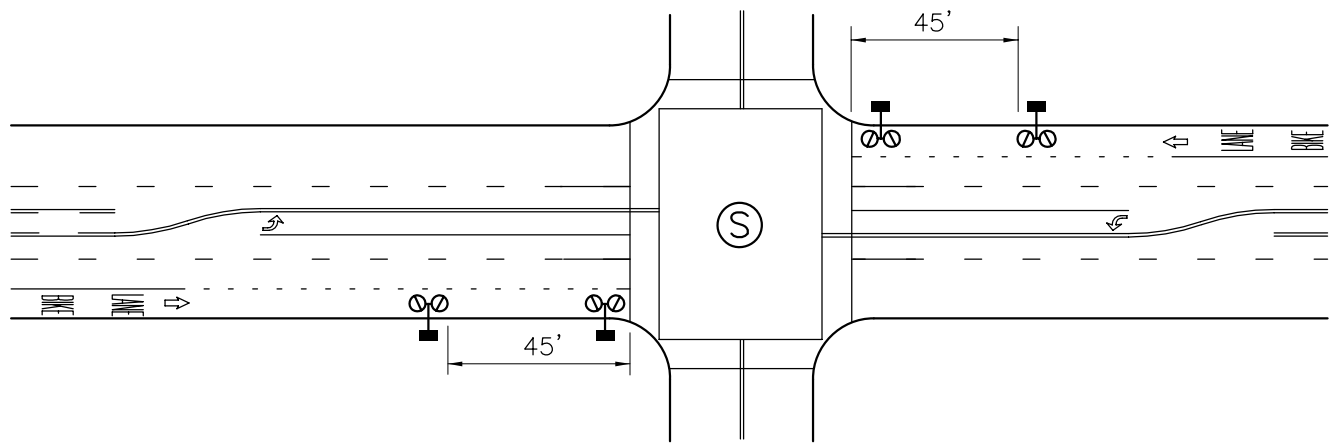

Bicycle Detection

Notes

1. The Bicycle Detector is used in bicycle lanes, on streets where the adjacent vehicle lanes are actuated, to call and extend the green for bicyclists.
2. The special detector configuration is sensitive to the limited metal content in bicycles.
3. The placement of the advance detectors recognizes their slower travel speeds (approximately 10 miles per hour), relative to those of motor vehicles, and enables bicyclists to extend the green in order to clear the intersection before the red is displayed. The placement of the advance detectors is optional.
4. Bicyclists at or upstream of the advance detectors can comfortably decelerate to a stop.
5. Bicycle detectors are shown in S-70.1D.

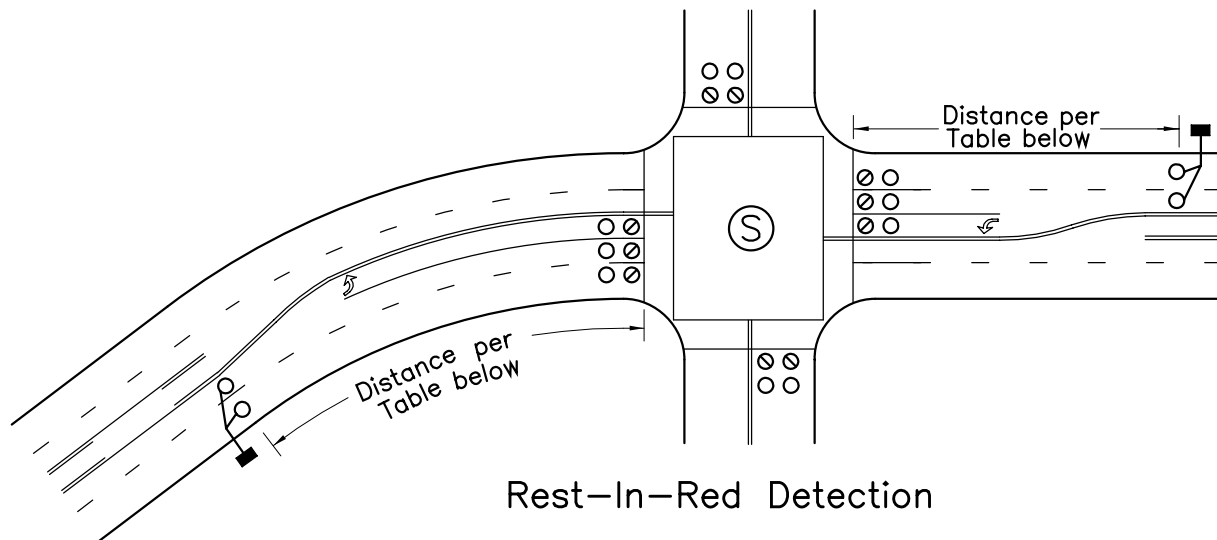

Rest-In-Red Detection

Detector Setback Table

Desired Speed mi/hr	Distance ft
15	45
20	70
25	105
30	140
35	185
40	230

Notes

1. Rest-In-Red Detectors are used to cause motorists to decelerate on the approach to a signal, where there is a documented accident pattern with excessive speed as the primary factor. The signal rests in red for all directions when there is no call. On the arterial approach it rests in red until the vehicle places a call at which time the signal turns green (assuming no call on the side street).
2. The detectors are placed at a safe stopping distance for the desired speed, such as the design speed of a curve, as shown in the table.
3. Motorists traveling at or below the desired speed will not start to decelerate when crossing the detector because the signal will immediately change to green.
4. Motorists traveling above the desired speed and who see the red display will start to decelerate upstream of the detector at or before a stopping distance corresponding to their speed. They will decelerate to a slower speed until they reach the detector at which point the signal will change to green, if there is no side street call.
5. Limit line detection is required for all approaches at Rest-In-Red locations.

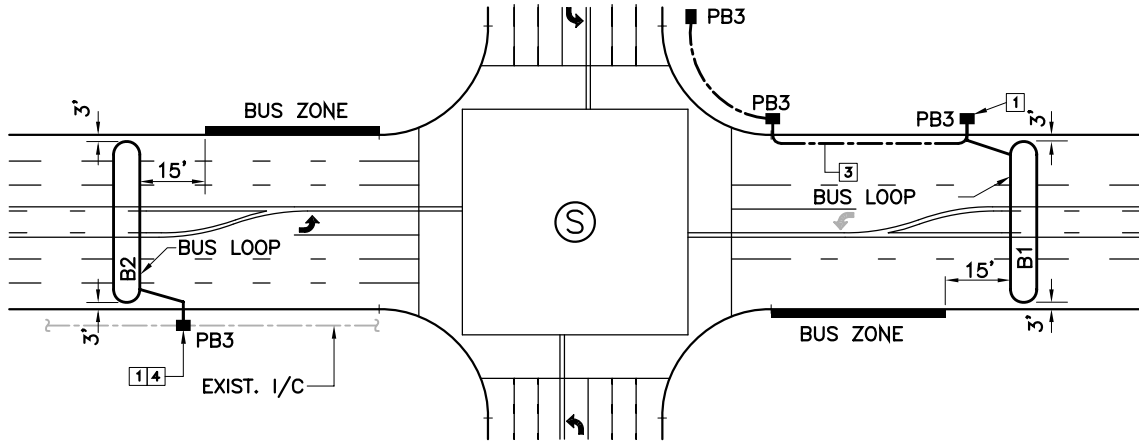

Bus Priority Detection with An Arterial Cross Street

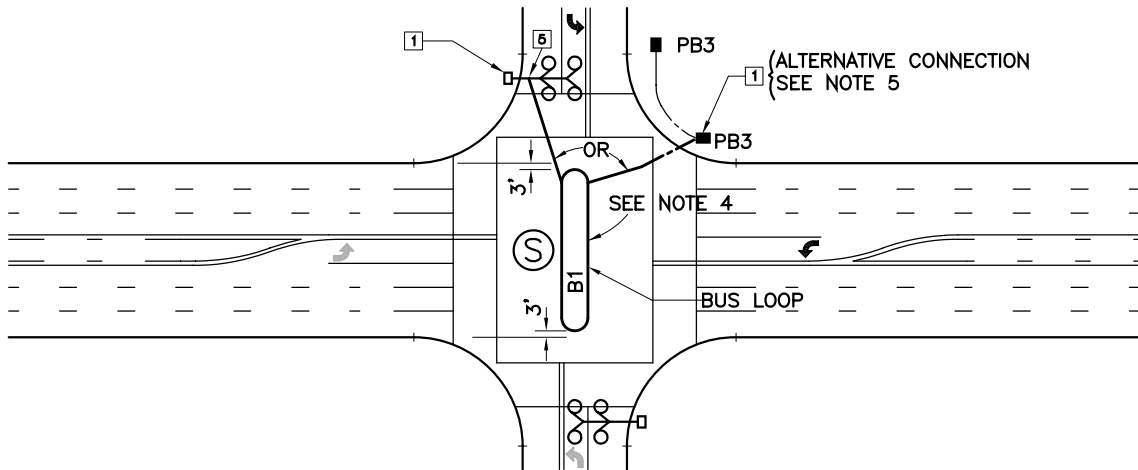

Bus Priority Detection with A Minor Cross Street

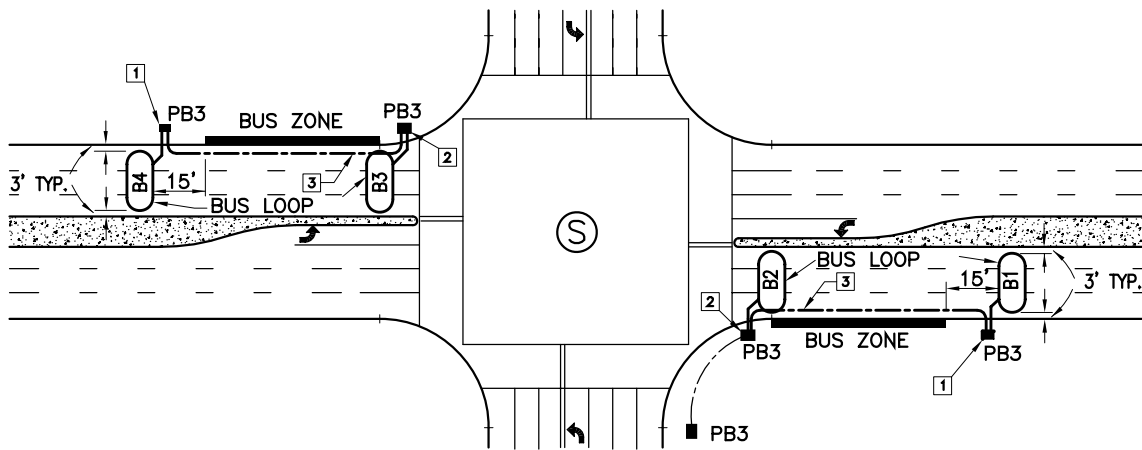

Bus Priority Detection on A Divided Street

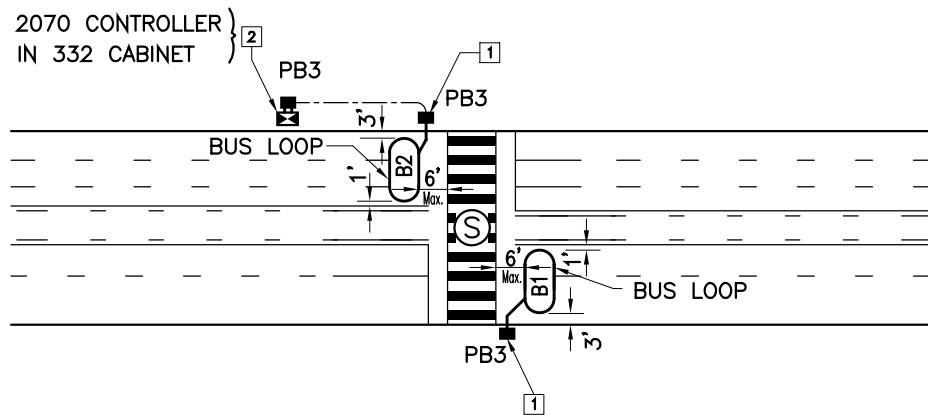

Bus Priority Detection at A Mid-Block Crosswalk Signal

Bus Priority Construction Notes:

- | | |
|--|--|
| <p>1 INSTALL ONE PAIR #12 AWG DLC FROM EACH LOOP TO CONTROLLER</p> <p>2 INSTALL TWO PAIR #12 AWG DLC FROM LOOP TO CONTROLLER</p> | <p>3 CONDUIT RUN ALONG OUTSIDE EDGE OF GUTTER.</p> <p>4 INTERCEPT CONDUIT AND INSTALL PULLBOX.</p> <p>5 PROTECT EXISTING LOOP.</p> |
|--|--|

Bus Priority Notes:

1. Use Model 2070 controller in a Type 332 cabinet.
2. Use 2" conduit for the bus loop, unless otherwise specified.
3. Loops 6'x40' and larger shall have one turn of wire. Smaller loops shall have two turns of wire.
4. Placement of the bus loop in the exact center of the cross street is not critical, and should be adjusted to avoid manholes, vaults, etc.
5. Where stamped crosswalks exist, stubout shall emerge within the center of intersection.
6. Bus priority loops are shown in S-70.1F.

- Longitudinal Visibility Application—See Sheet 2
- Lateral Visibility
 - General Notes—See Sheet 3
 - Visibility Nomographs—See Sheets 4 ~ 9
 - Beveled Visor Application—See Sheet 10
 - Long Visor Application—See Sheet 11
 - Programmed Visibility Application—See Sheet 12

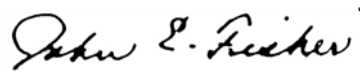
DWN	MT	12-06-05	Title	Application of Visibility—Limited Traffic Signal Heads	
CKD					
T. E.					
Sr. T. E.					
Pr. T. E.	SS	1-25-06	CITY OF LOS ANGELES DEPARTMENT OF TRANSPORTATION		
Approved			January 30, 2006	Drawing No.	
			S-85.0		
for Frances T. Banerjee, Interim General Manager					

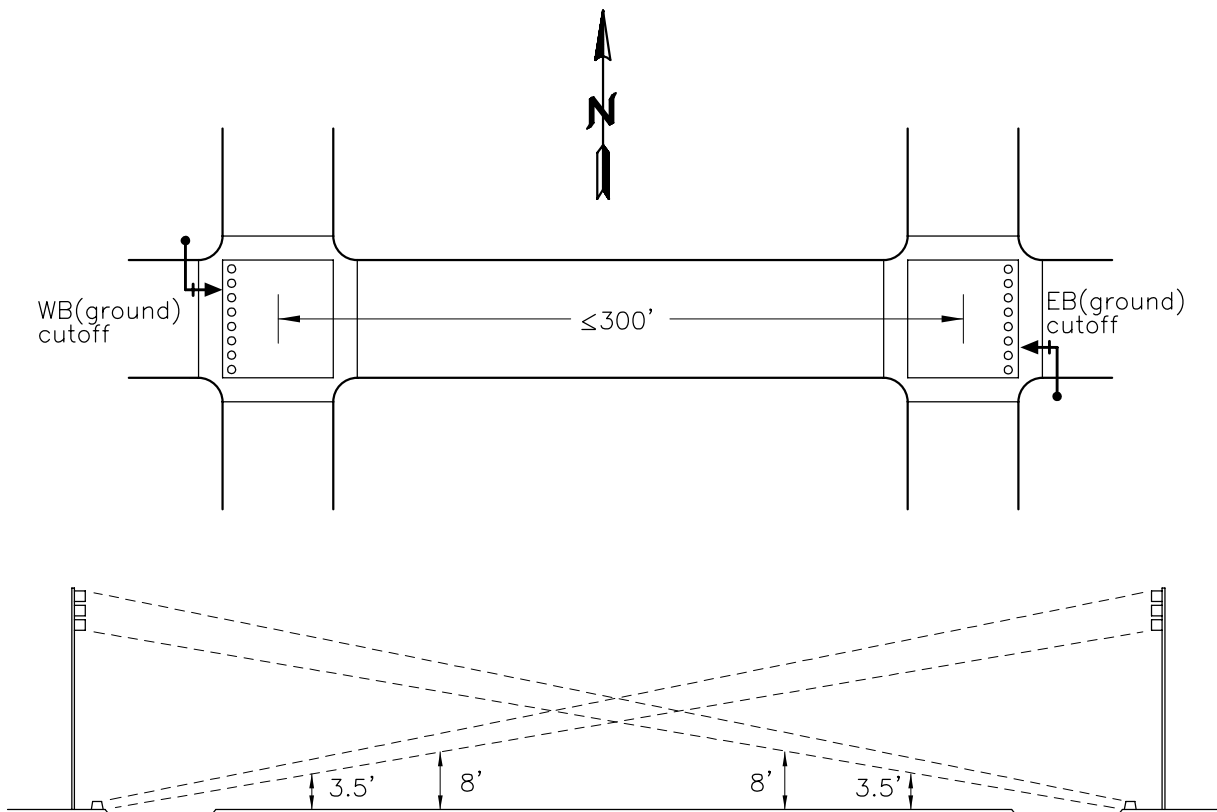

At the point where the visibility is 3.5' above ground passenger car motorists can see the signal. Where it is 8' all bus and truck drivers can see it.

1. Use programmed visibility heads for longitudinal cut-off where the distance between signalized intersections is 300' or less.
2. Mask the downstream green display so that a motorist stopped on red at the upstream signal will not inadvertently act on the downstream green display. Mask the downstream red display so that a motorist receiving a green at the upstream signal will not inadvertently act on the downstream red display.
3. Do not mask yellow displays so that drivers of buses and tall trucks can see the change interval in time to safely decelerate to a stop. The masked red display becomes visible after the yellow display terminates.
4. Use the longest ground cut-off feasible, so as to maximize visibility once motorists discharge from the upstream signal. Yet, use a practical physical point in the field, such as a crosswalk line or prolongation of the curb line. Due to "bleeding", use inside not outside crosswalk line. On the signal plan show the physical point and not just the distance to the ground cut-off.

Longitudinal Visibility :
 Programmed Visibility Head Application [ PV (G,R only)]

Lateral Visibility Notes

1. At skewed or jogged intersections traffic signal heads are to be evaluated for the need to restrict lateral visibility. To the extent possible all farside signal heads are to be designed to be configured so that no more than 50% of the lens width can be seen by motorists positioned anywhere along the stop line of a conflicting approach.
2. Where restricted lateral visibility is necessary, right or left beveled visors, long visors or programmed visibility heads are to be used. Louvers are not to be used, as they limit visibility to all approaches.
3. Right and left beveled visors restrict visibility to one side only. Long visors restrict visibility to both sides. Programmed visibility sections can be masked to restrict visibility to either or both sides.
4. Where they adequately restrict lateral visibility, beveled (right or left) or long visors are to be used in preference to programmed visibility heads. The latter can "bleed" beyond its masked limits during low light conditions.
5. Programmed Visibility heads have relatively narrow visibility cones as compared with standard heads. Where they are considered for application the designer should check to see that the visibility cone is adequate for the controlled approach.
6. Clear acetate copies of visibility nomographs should be used to determine applicability of each type of laterally restricted head.

Visibility Nomograph for Standard Visor Head

Place the line for "Center of Signal Head Alignment" along assumed alignment of head. Determine conformance with restricted visibility to conflicting approaches.

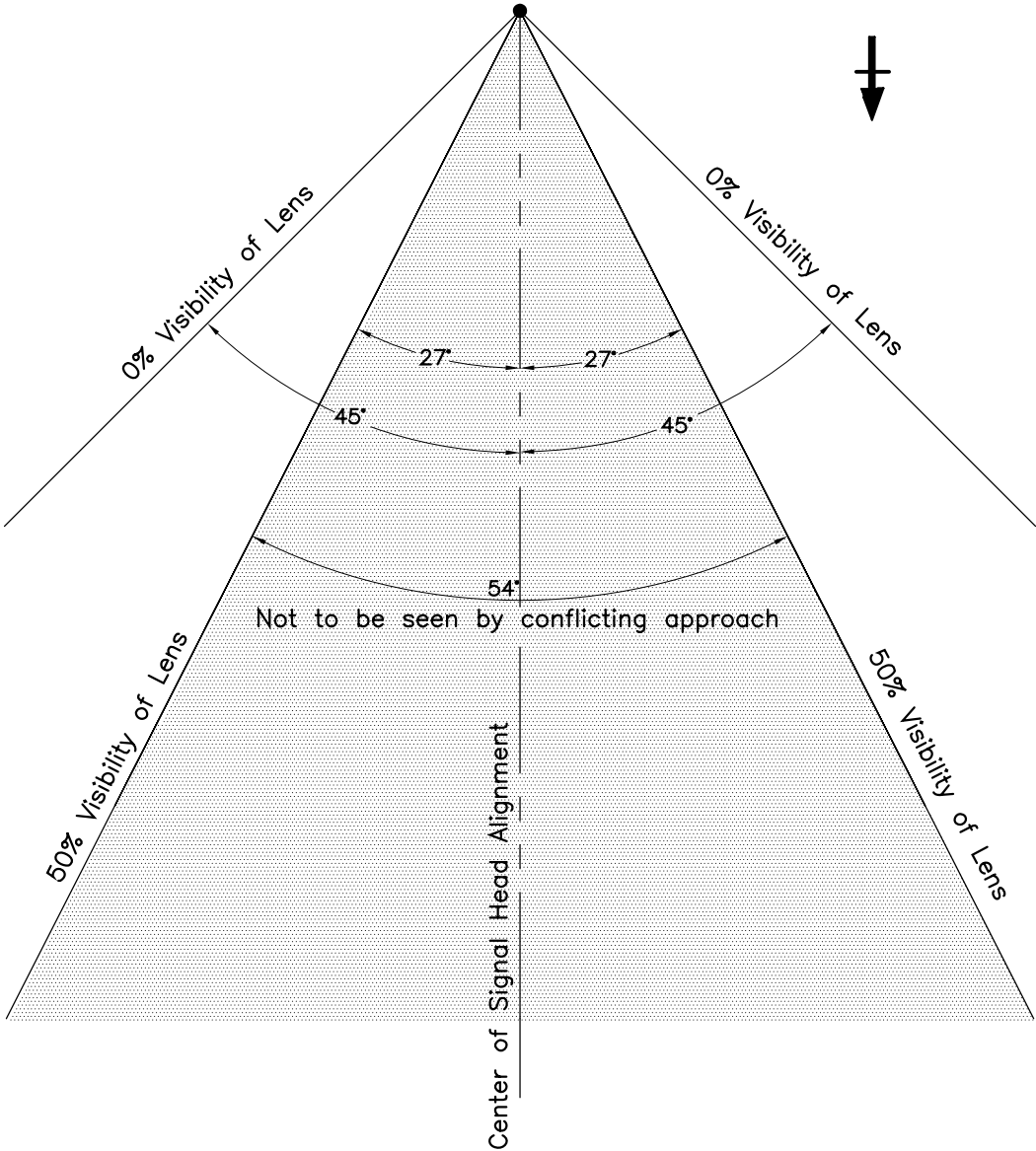

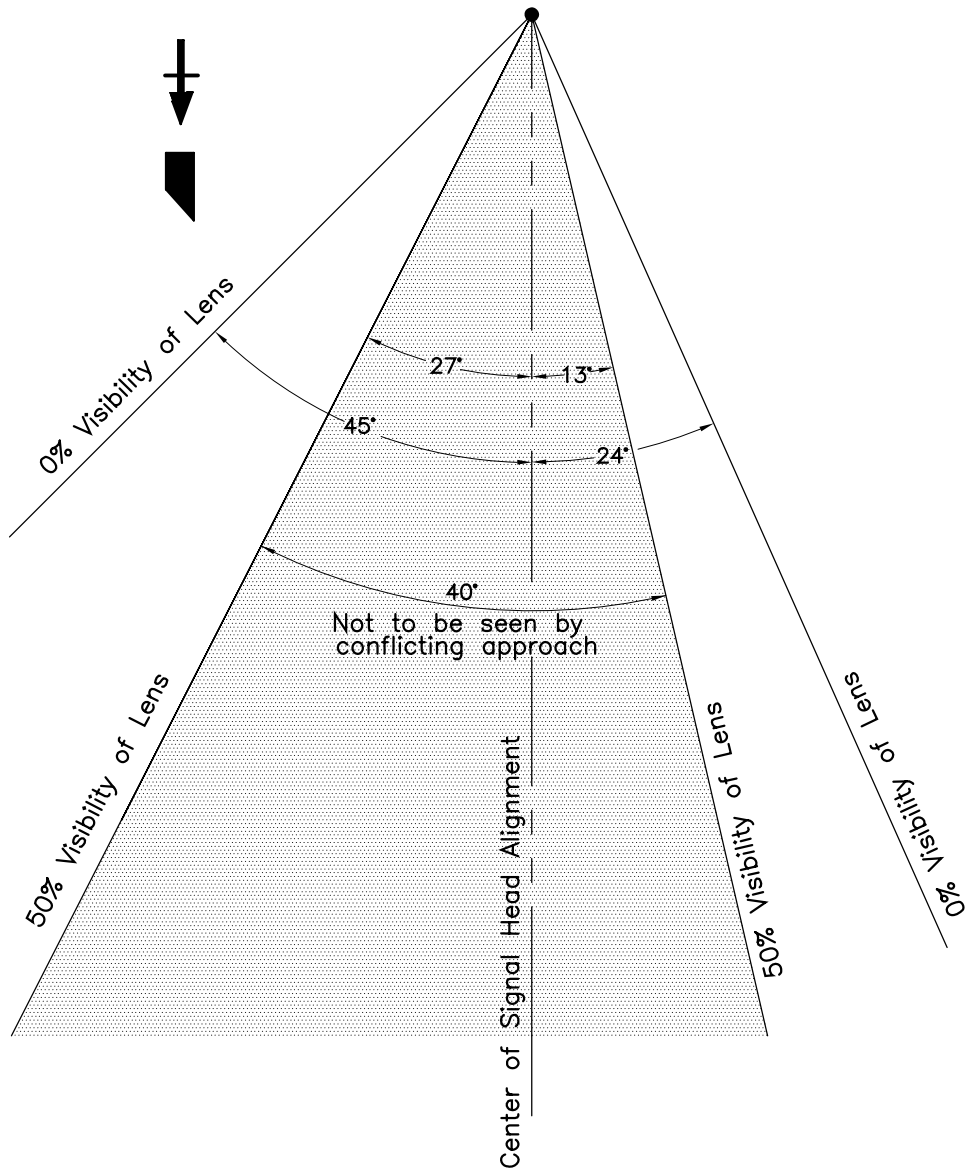

Visibility Nomograph for Right Beveled Visor Head

Place the line for "Center of Signal Head Alignment" along assumed alignment of head.
Use to determine conformance with restricted visibility to conflicting approaches.

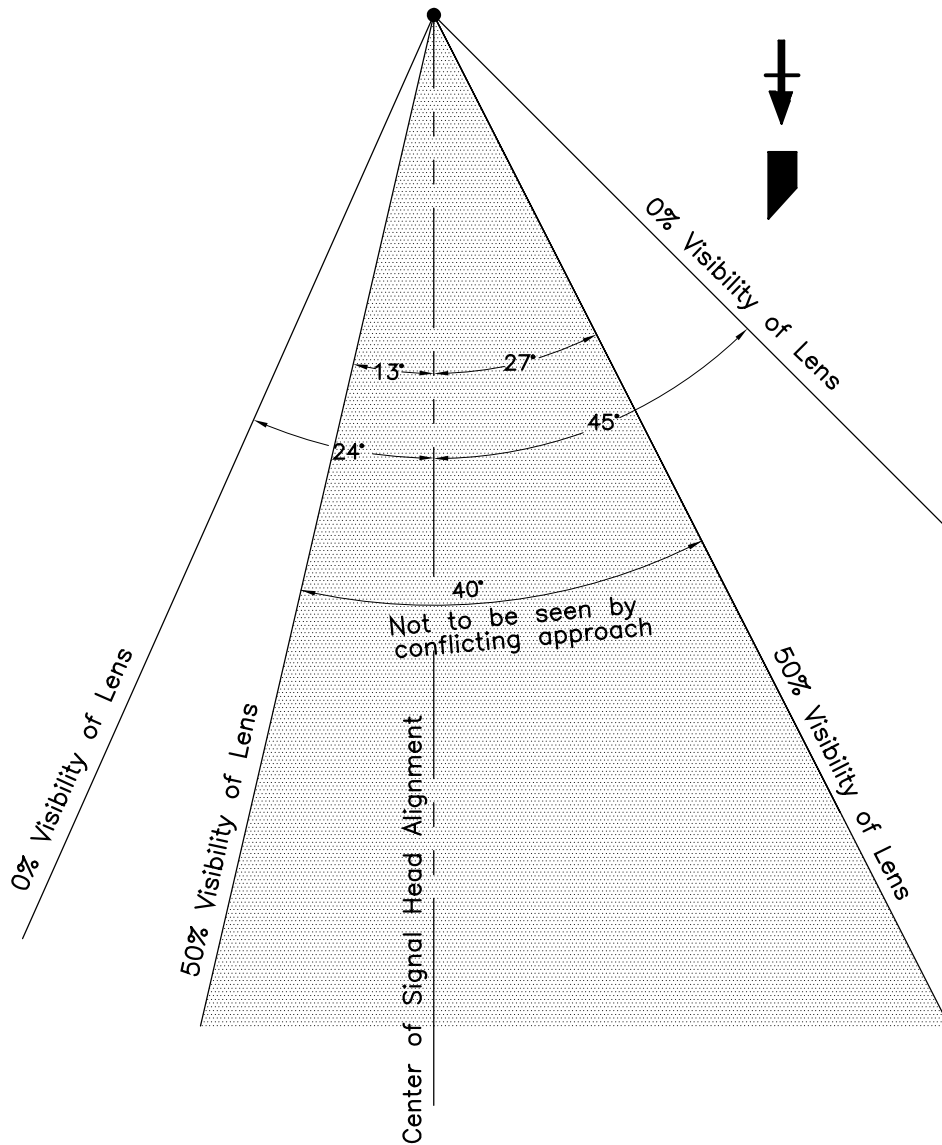

Visibility Nomograph for Long Visor Head

Place the line for "Center of Signal Head Alignment" along assumed alignment of head.
Use to determine conformance with restricted visibility to conflicting approaches.

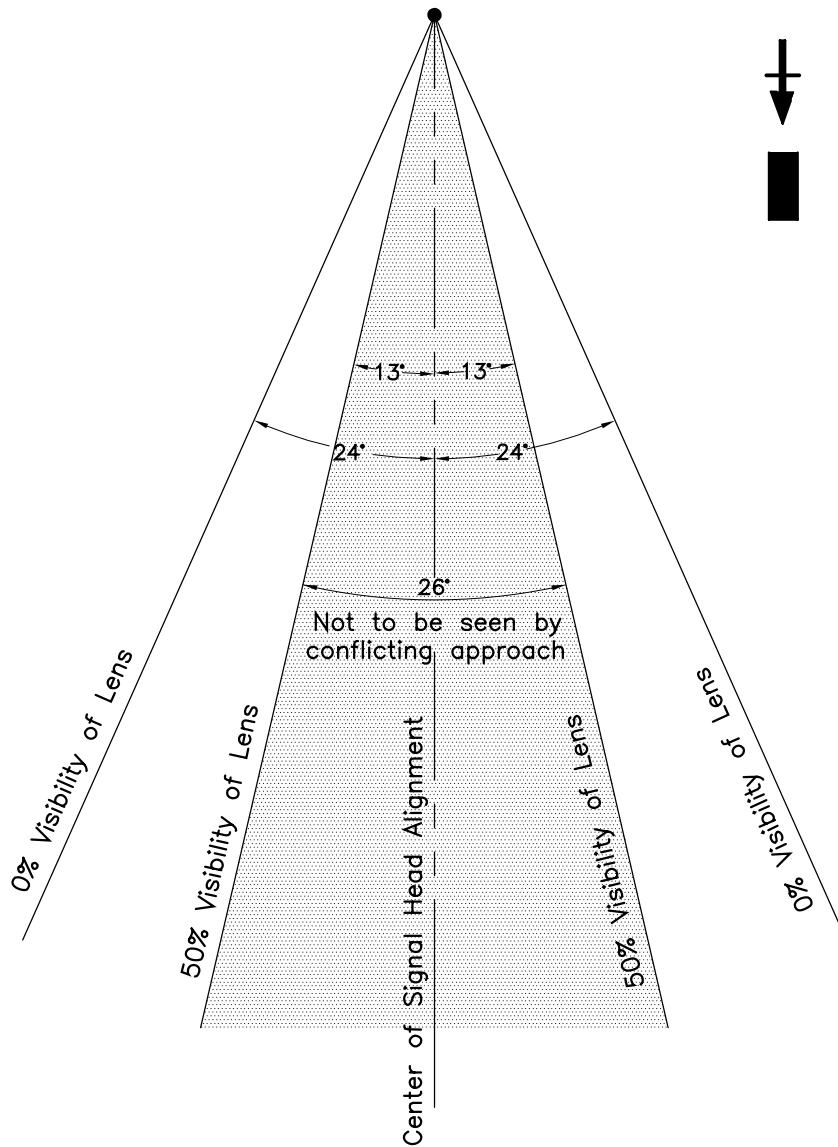

Visibility Nomograph for Programmed Visibility Head

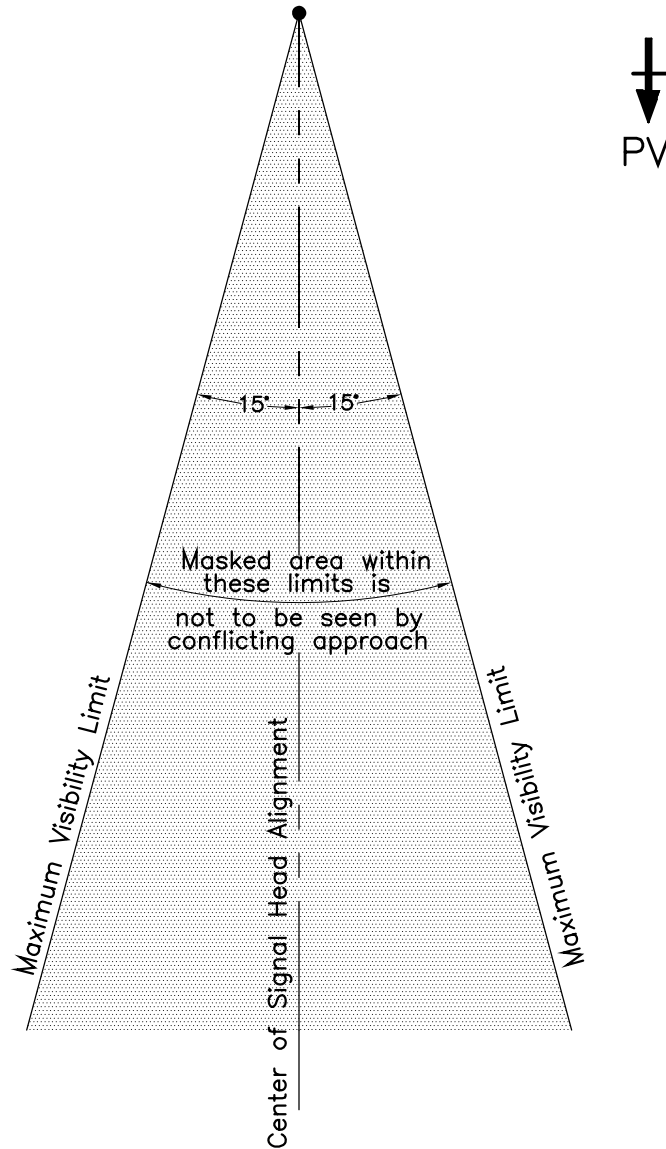

Place the line for "Center of Signal Head Alignment" along assumed alignment of head. The cone of visibility of the head can be masked within the limits shown. Use to restrict lateral visibility when beveled or long visors do not provide the required restriction. Check to see if the cone-of-visibility is adequate for all applicable approach lanes. During low light conditions programmed visibility heads can "bleed" beyond the masked limits.

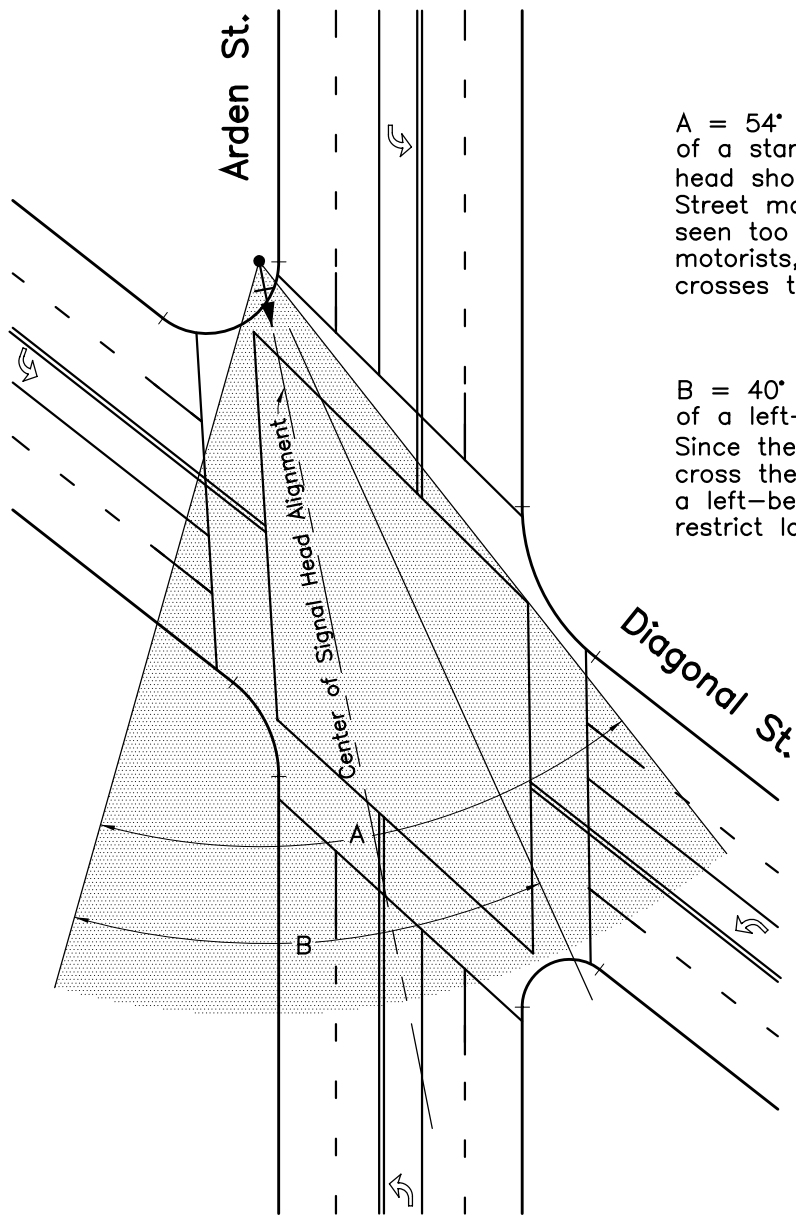



A = 54° Angle of 50% lens visibility of a standard signal head. The signal head shown is intended for Arden Street motorists. However, it can be seen too easily by Diagonal Street motorists, since the Angle A shading crosses that limit line.

B = 40° Angle of 50% lens visibility of a left-beveled visor signal head. Since the Angle B shading does not cross the limit line on Diagonal Street a left-beveled visor would adequately restrict lateral visibility.

Lateral Visibility:
 Beveled Visor Application ( or )

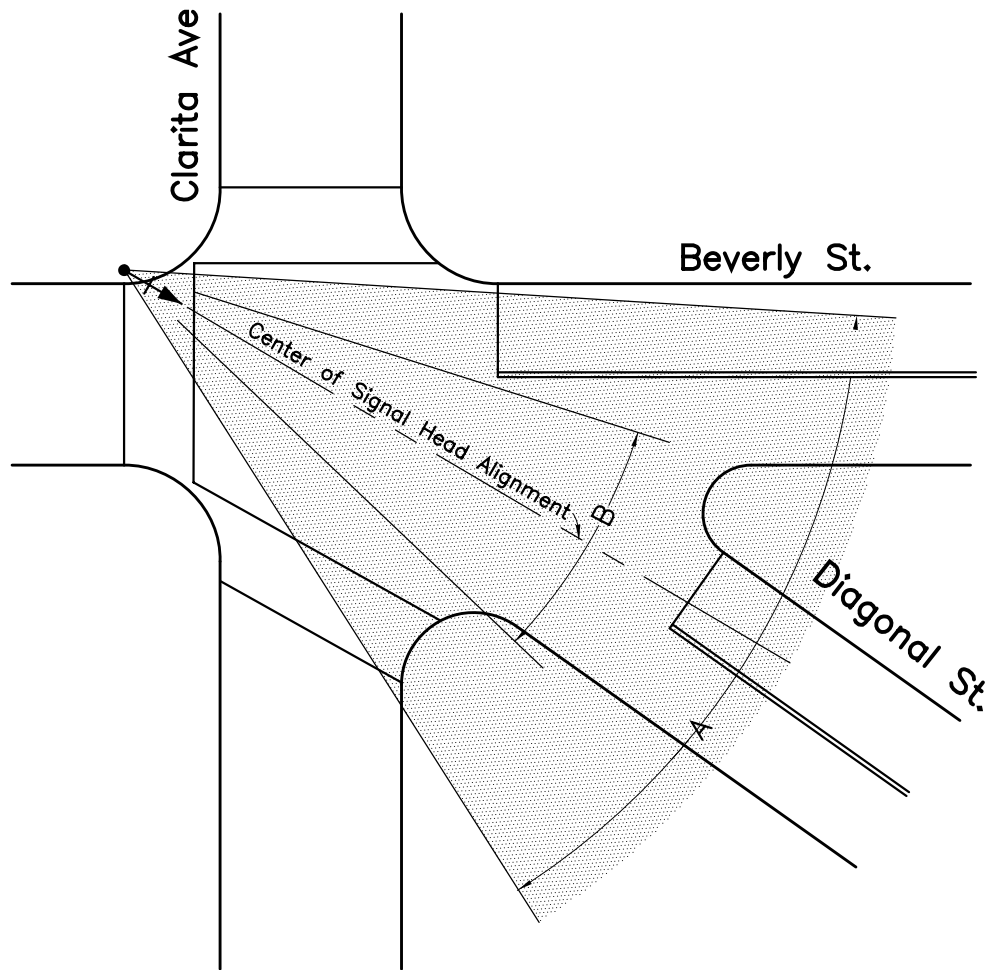

A = 54° Angle of 50% lens visibility of a standard signal head. The signal head shown is intended for Diagonal Street motorists. However, it can be seen too easily by Beverly Street and Clarita Avenue motorists, since the Angle A shading crosses their respective limit lines.

B = 26° Angle of 50% lens visibility of a long visor signal head. Since the Angle B shading does not cross the limit line on Beverly Street nor on Clarita Avenue a long visor would adequately restrict lateral visibility.

Lateral Visibility:
Long Visor Application (➔ ■)

Clarita Ave

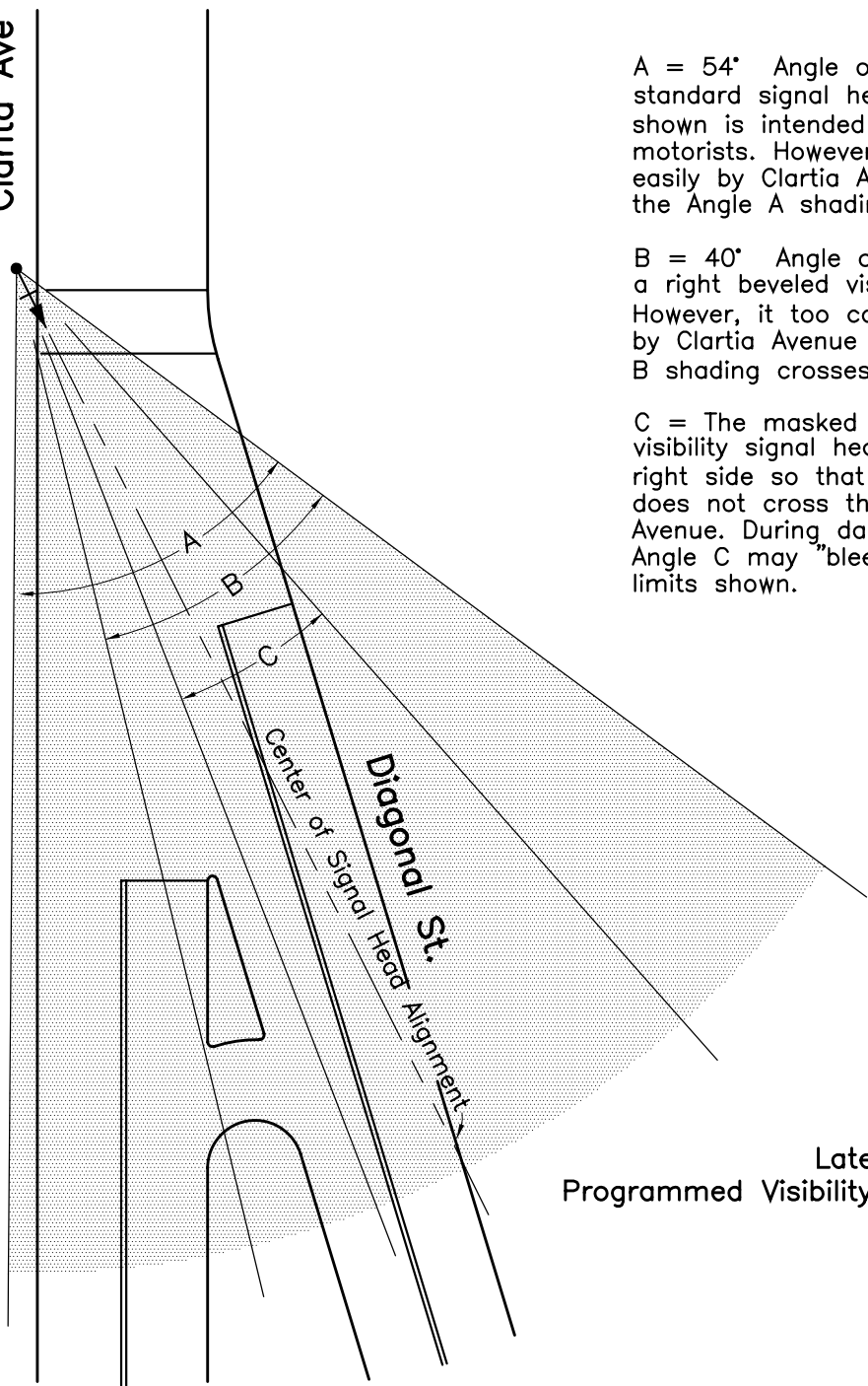

A = 54° Angle of 50% lens visibility of a standard signal head. The signal head shown is intended for Diagonal Street motorists. However, it can be seen too easily by Clarita Avenue motorists, since the Angle A shading crosses that limit line.

B = 40° Angle of 50% lens visibility of a right beveled visor signal head. However, it too can be seen too easily by Clarita Avenue motorists, since the Angle B shading crosses that limit line.

C = The masked angle of a programmed visibility signal head. It is masked on the right side so that the Angle C shading does not cross the limit line on Clarita Avenue. During dark weather and at night Angle C may "bleed" beyond the nominal limits shown.

Lateral Visibility:
Programmed Visibility Head Application (→ PV)

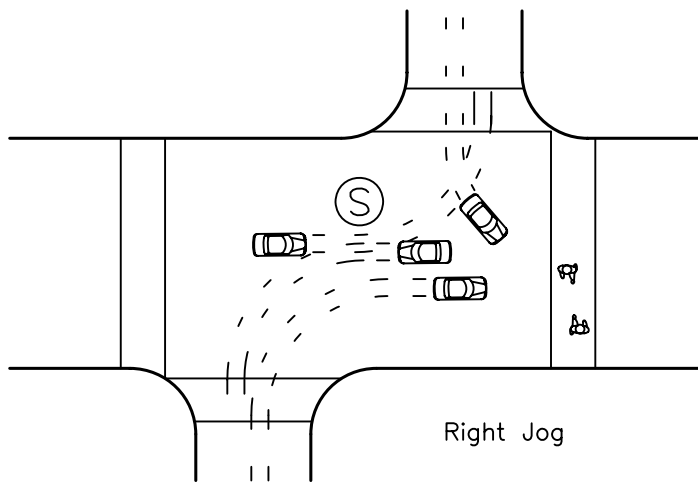

- Pedestrians might not be seen early-on by right-turning motorists.
- Opposing vehicles might not be seen early-on.
- Opposing arterial left turns might interlock.

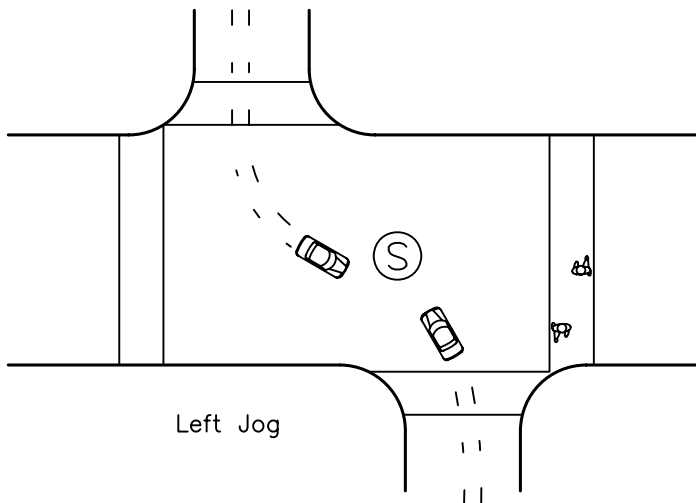

- Pedestrians might not be seen early-on by left-turning motorists.
- Opposing vehicles might not be seen early-on.
- Opposing left turns interlock.
- Difficult to determine if motorist is making a left turn or jogged through move.
- So-called opposing moves momentarily can be positioned at approximately right angles to each other.

Operational Challenges for the Minor Street Approaches to Signalized Jogged Intersections

To select the most appropriate design for minimizing the above challenges see Sheet 2.

DWN	EC	6-10-10	Title Operation and Design of Signalized jogged Intersections	1/12
CKD				
T. E.				
Sr. T. E.				
Pr. T. E.				
Approved June 24, 2010			CITY OF LOS ANGELES DEPARTMENT OF TRANSPORTATION	
for 			Drawing No. S-100.0	
Rita L. Robinson, General Manager				

θ_1 & θ_2 = angle between motorist looking straight ahead and back of opposing vehicle
 X_1 & X_2 = Distance along arterial from the crosswalk line or limit line to the signal pole or BCR at the far side of the first intersecting leg.
 D = Internal storage distance between real or hypothetical interior limit lines. For minor offset D may be a small or negative number.

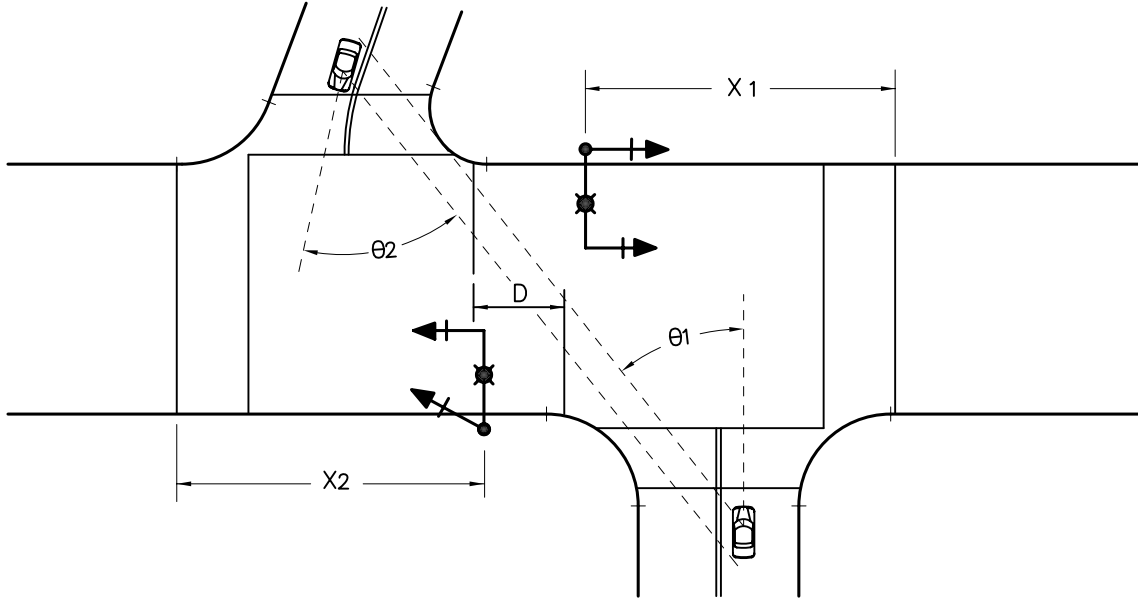

To select the most appropriate design:

- 1) Determine if there is a Left Jog or a Right Jog
 See Sheets 3, 5, 7, 9, 10 and 11 for left jogged intersections and Sheets 4, 6, 8 and 12 for right jogged intersections.
- 2) Determine D
 If $D \geq 40'$ then interior limit lines are required. If $D < 40'$ then the jog is operated as a single intersection. See Sheets 10, 11 and 12 for intersections with interior limit lines and Sheets 3 through 9 for single intersection operation.
- 3) Determine θ_1 and θ_2
 If θ_1 or θ_2 is $> 20^\circ$ and $D < 40'$ then some form of opposed phasing is required for the minor street. See Sheets 7 through 9 for situations requiring opposed phasing. See Sheets 3 through 6 for situations for which concurrent phasing is adequate. Note that for Sheets 4 and 6 opposed phasing is required if diagonal crosswalks are not feasible, due to the unexpected presence of pedestrians crossing the path of right-turning motorists.
- 4) Determine X_1 and X_2
 If X_1 and $X_2 \geq 50'$ and $D < 40'$ then only internal mastarms are to be used on the arterial street. If X_1 and $X_2 < 50'$ then only external mastarms are to be used on the arterial street. See Sheets 3, 4, 7, and 8 for internal mastarm designs and Sheets 5, 6 and 9 for external mastarm designs.

Note:

The drawings on Sheets 3 through 12 are not intended to show the required safety lighting design. Final lighting designs may not include the depicted mastarm lighting and and likely will include other lighting locations not shown.

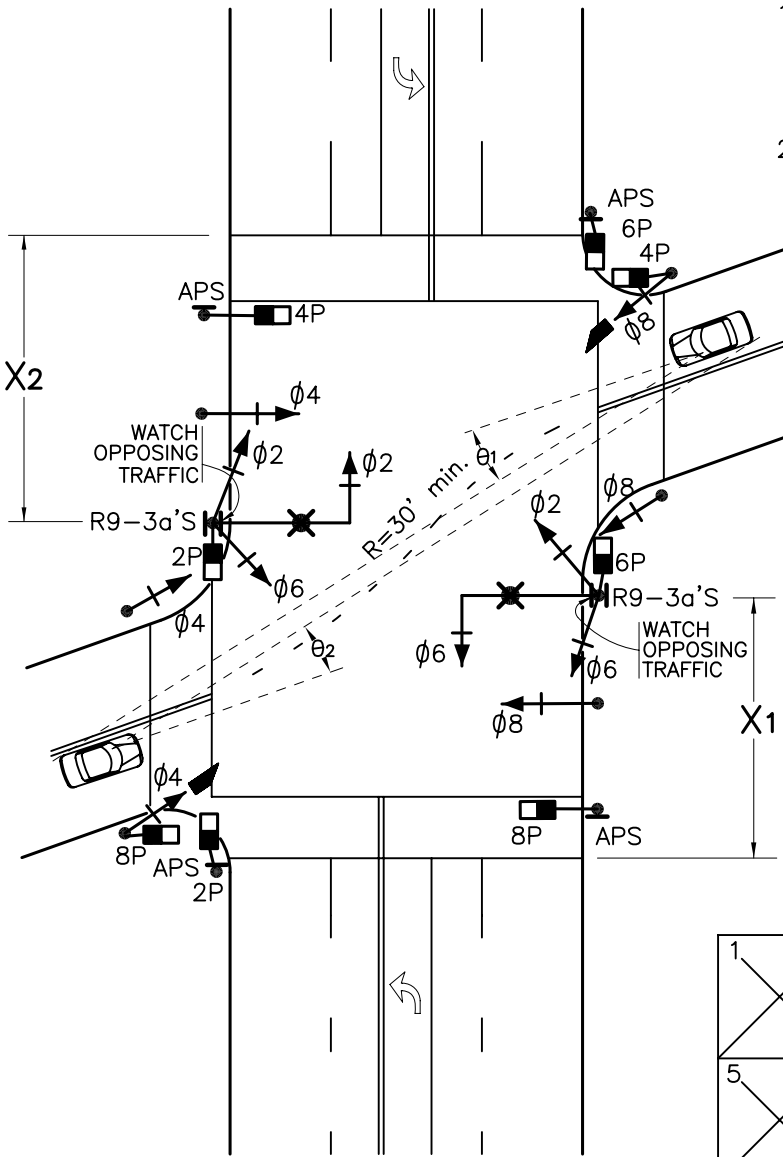

- 1) Install where:
 - a) $D < 40'$; and
 - b) θ_1 and $\theta_2 \leq 20^\circ$; and
 - c) X_1 and $X_2 \geq 50'$
- 2) The beveled visors shown should be installed only where cross-traffic motorists would see 50% or more of the lens area of a far-side signal as they wait at the limit line. PV heads should be used if beveled visors would not be adequate.

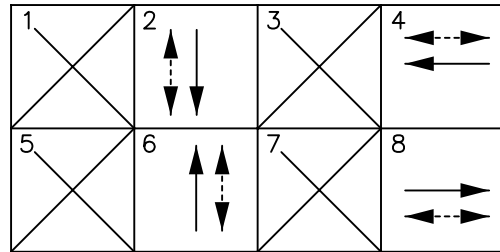

Left jogged Intersection
Internal Mastarms

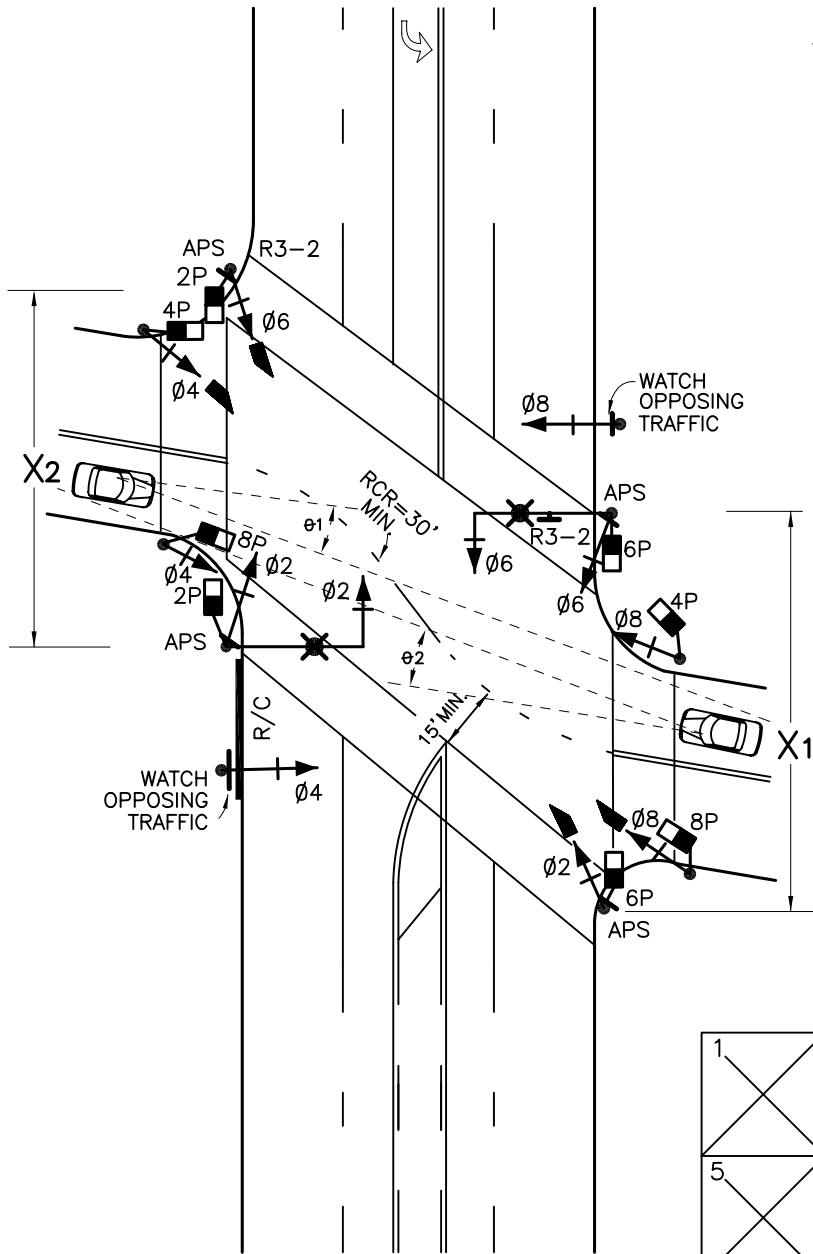

- 1) Install where:
 - a) $D < 40'$; and
 - b) θ_1 and $\theta_2 \leq 20^\circ$; and
 - c) X_1 and $X_2 \geq 50'$; and
 - d) Diagonal crosswalks are feasible
- 2) Where diagonal crosswalks are not feasible, use opposed phasing, as shown on Sheet 8.
- 3) The treatment to allow arterial left turns in one direction and prohibited in the other direction is an operational option. For other typical left turn operations on the arterial street see Sheets 6 and 8.
- 4) The beveled visors shown should be installed only where cross-traffic motorists would see 50% or more of the lens area of a far-side signal as they wait at the limit line. PV heads should be used if beveled visors would not be adequate.

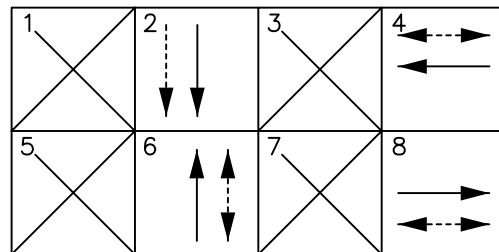

Right jogged Intersection
Prohibited Left Turn

- 1) Install where:
 - a) $D < 40'$; and
 - b) θ_1 and $\theta_2 \leq 20^\circ$; and
 - c) X_1 and $X_2 < 50'$

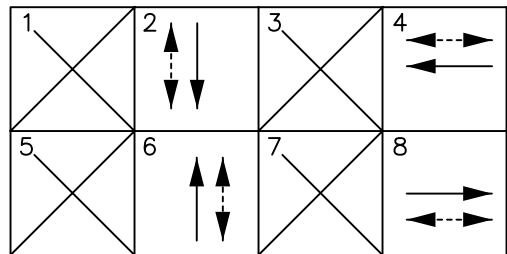
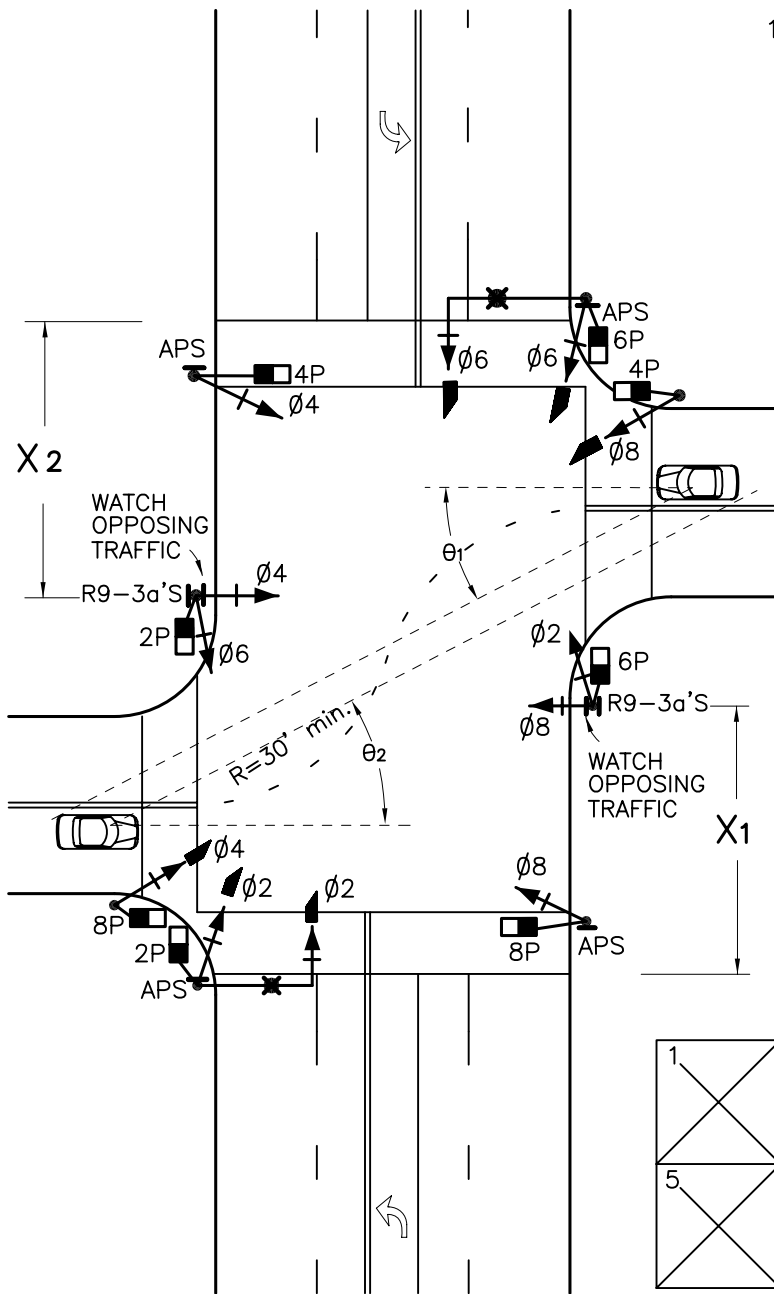

Left jogged Intersection
External Mastarms

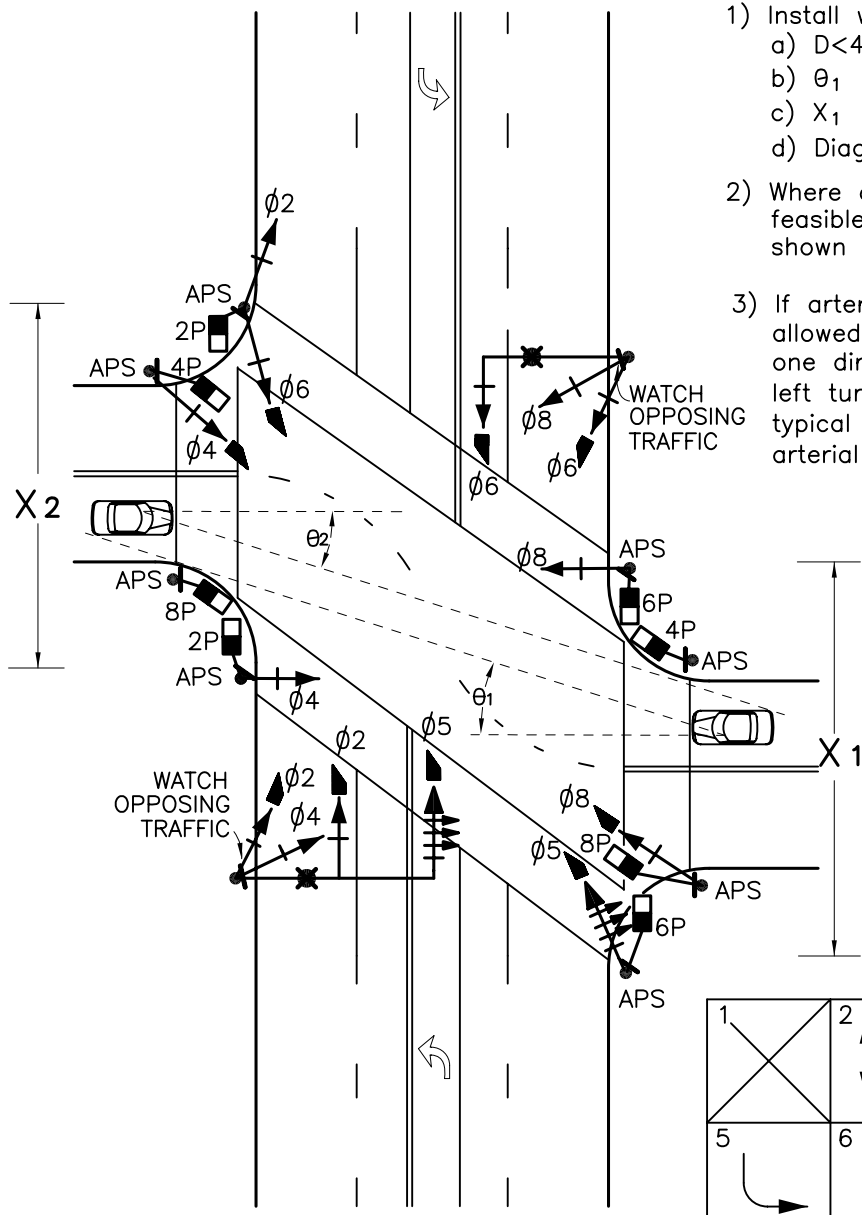

- 1) Install where:
 - a) $D < 40'$; and
 - b) θ_1 and $\theta_2 \leq 20^\circ$; and
 - c) X_1 and $X_2 < 50'$; and
 - d) Diagonal crosswalks are feasible
- 2) Where diagonal crosswalks are not feasible, use opposed phasing, as shown on Sheet 8.
- 3) If arterial left turns are to be allowed in both directions, at least one direction shall have protected left turns, as shown. For other typical left turn options on the arterial street see Sheets 4 and 8.

Right jogged Intersection
Protected Left Turn

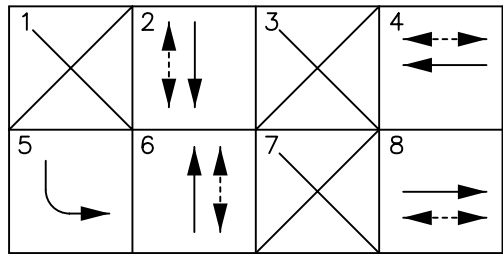

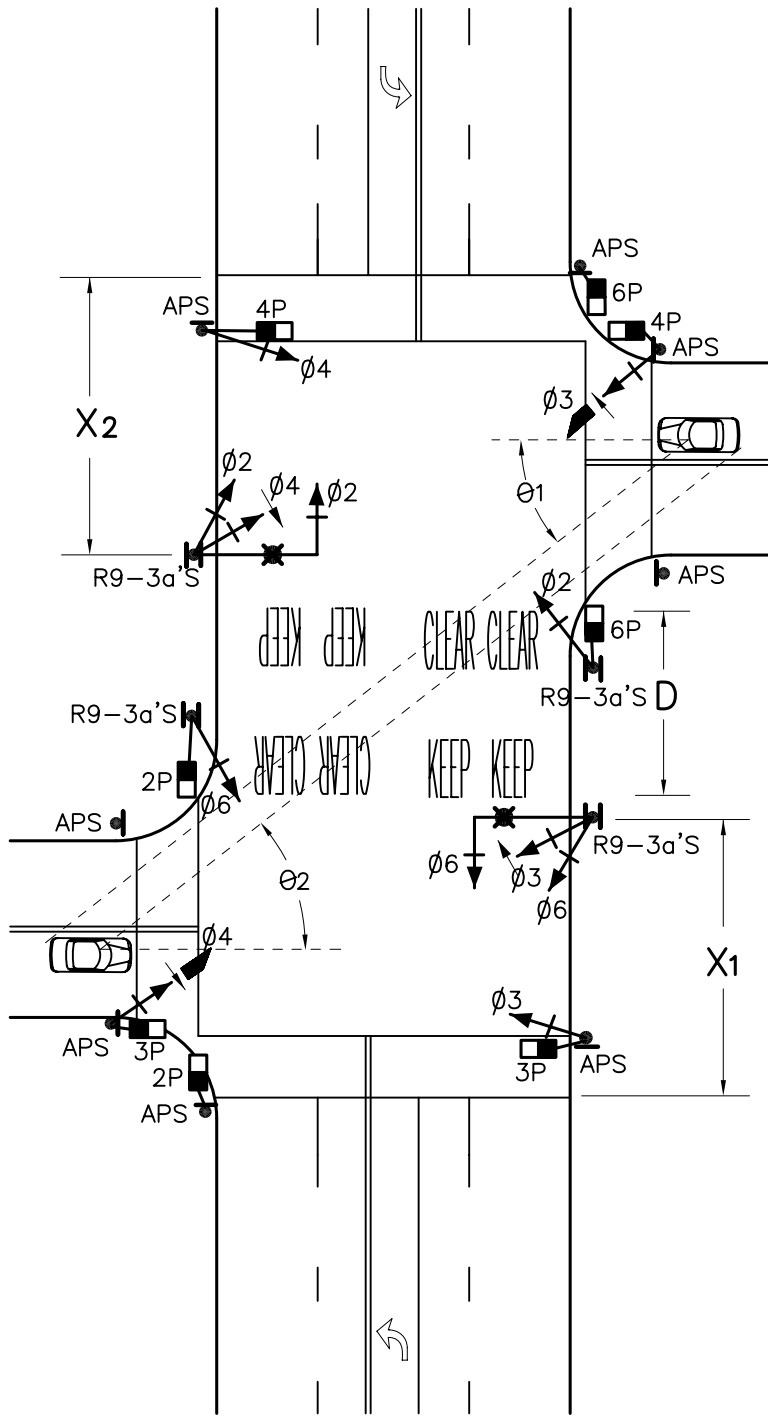

Left jogged Intersection
Internal Mastarms/Opposed Phasing

- 1) Install where:
 - a) $D < 40'$; and
 - b) θ_1 or $\theta_2 > 20'$
- 2) The alternate signal phasing schemes shown below, with corresponding signal head modifications (not shown), should be used only where the intersection would be operating near capacity with the more conventional opposed phasing. Generally, the alternate phasing would be necessary where pedestrian calls occur on most cycles. Where used, the lighter volume side street approach should have the left arrow indications. If one or both of the crosswalks across the arterial street can be eliminated, then the intersection operation can have more efficient phasing than shown.
- 3) Where $D \geq 20'$, "KEEP CLEAR" pavement markings should be installed between the cross street legs, as shown.

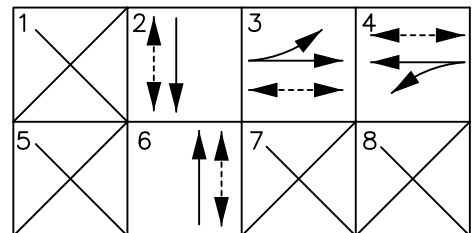

Alternate 1

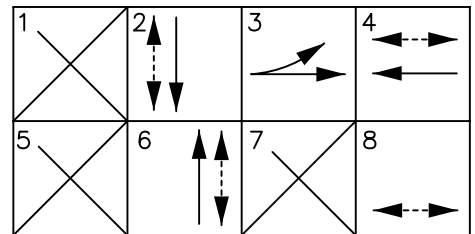

Alternate 2

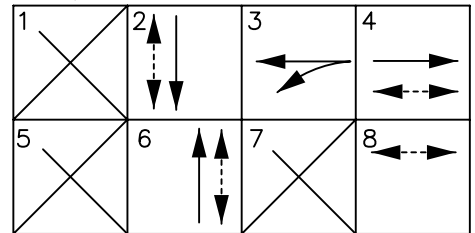

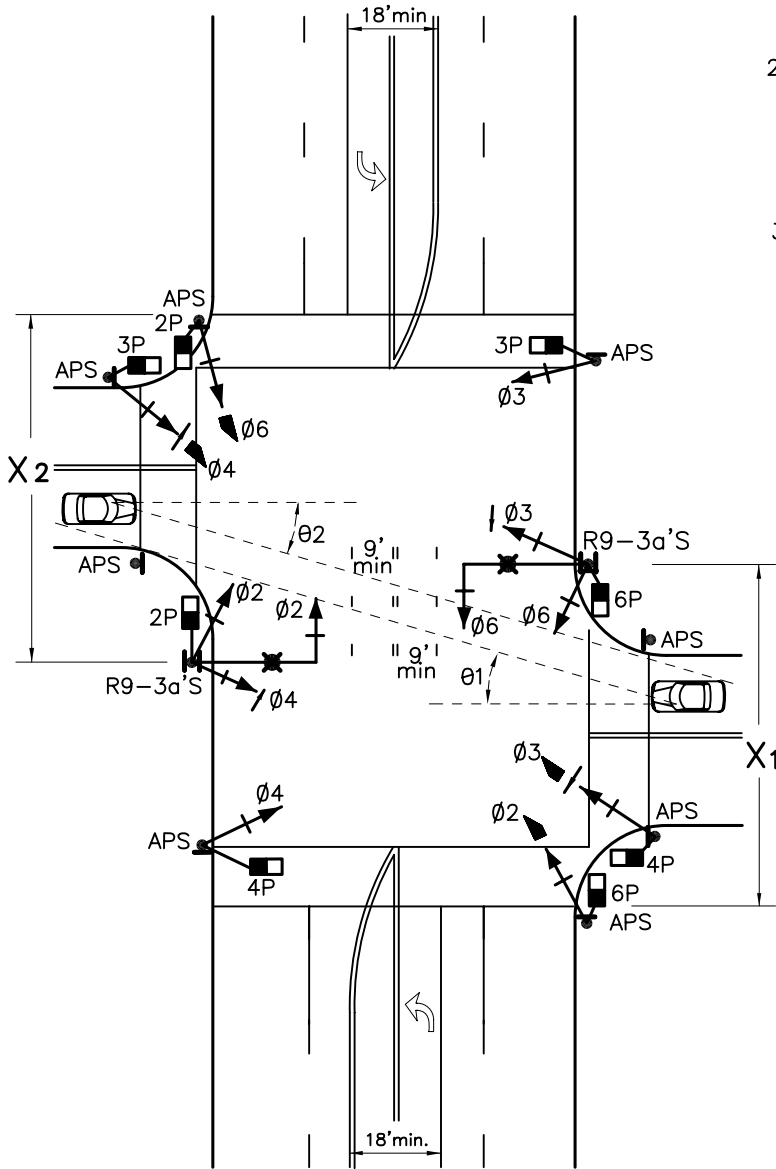

Right Jogged Intersection
Internal Mastarms
Opposed Phasing

- 1) Install where:
 - a) $D < 40'$; and
 - b) θ_1 or $\theta_2 > 20^\circ$
 - c) X_1 and $X_2 \geq 50'$
- 2) The arterial, cat-tracked side-by-side left-turn lanes, as shown, are possible only where the painted median channelization is at least 18' wide. For other typical left turn options on the arterial street see Sheets 4 and 6.
- 3) The alternate signal phasing schemes shown below with corresponding signal head modifications should be used only where the intersection would be operating near capacity with the more conventional opposed phasing. Generally, the alternate phasing would be necessary where pedestrian calls occur on most cycles. Where used, the lighter volume side street approach should have the right arrow indications. If one or both of the crosswalks across the arterial street can be eliminated, then the intersection operation can have more efficient phasing than shown.
- 4) Where $D \geq 20'$ "KEEP CLEAR" pavement markings should be installed between the cross street legs, as shown in Sheet 7.

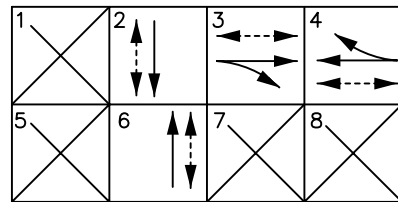

Alternate 1

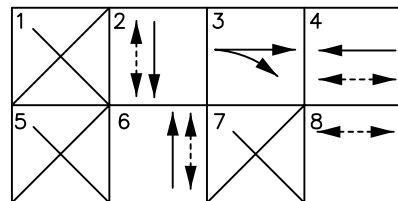

Alternate 2

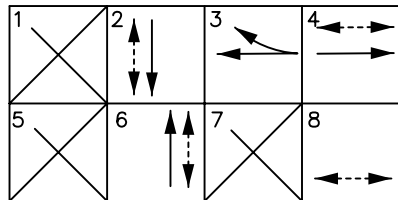

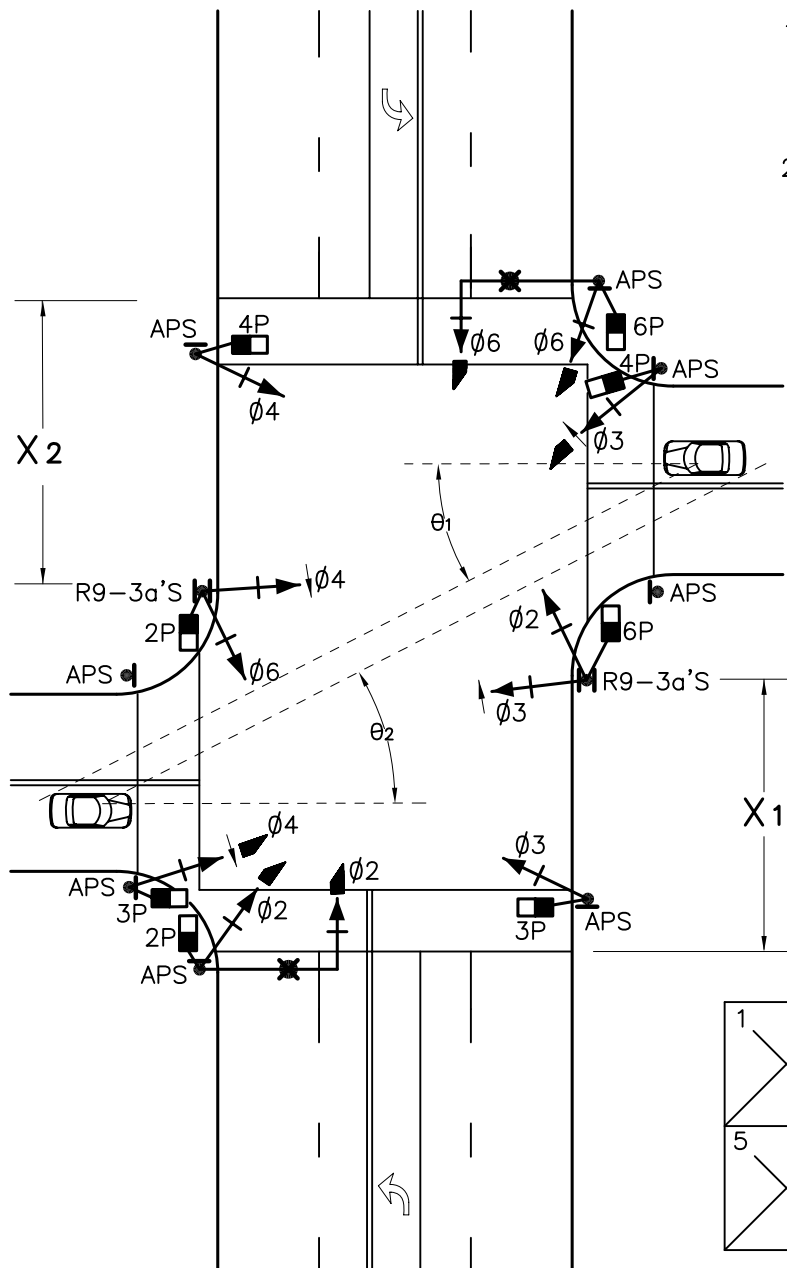

- 1) Install where:
 - a) $D < 40'$; and
 - b) θ_1 or $\theta_2 > 20^\circ$; and
 - c) X_1 and $X_2 < 50'$
- 2) See Sheet 7 for alternate signal phasing schemes.

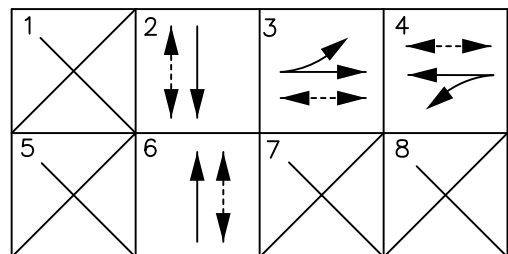

Left jogged Intersection
External Mastarms/Opposed Phasing

Install where $D \geq 40'$

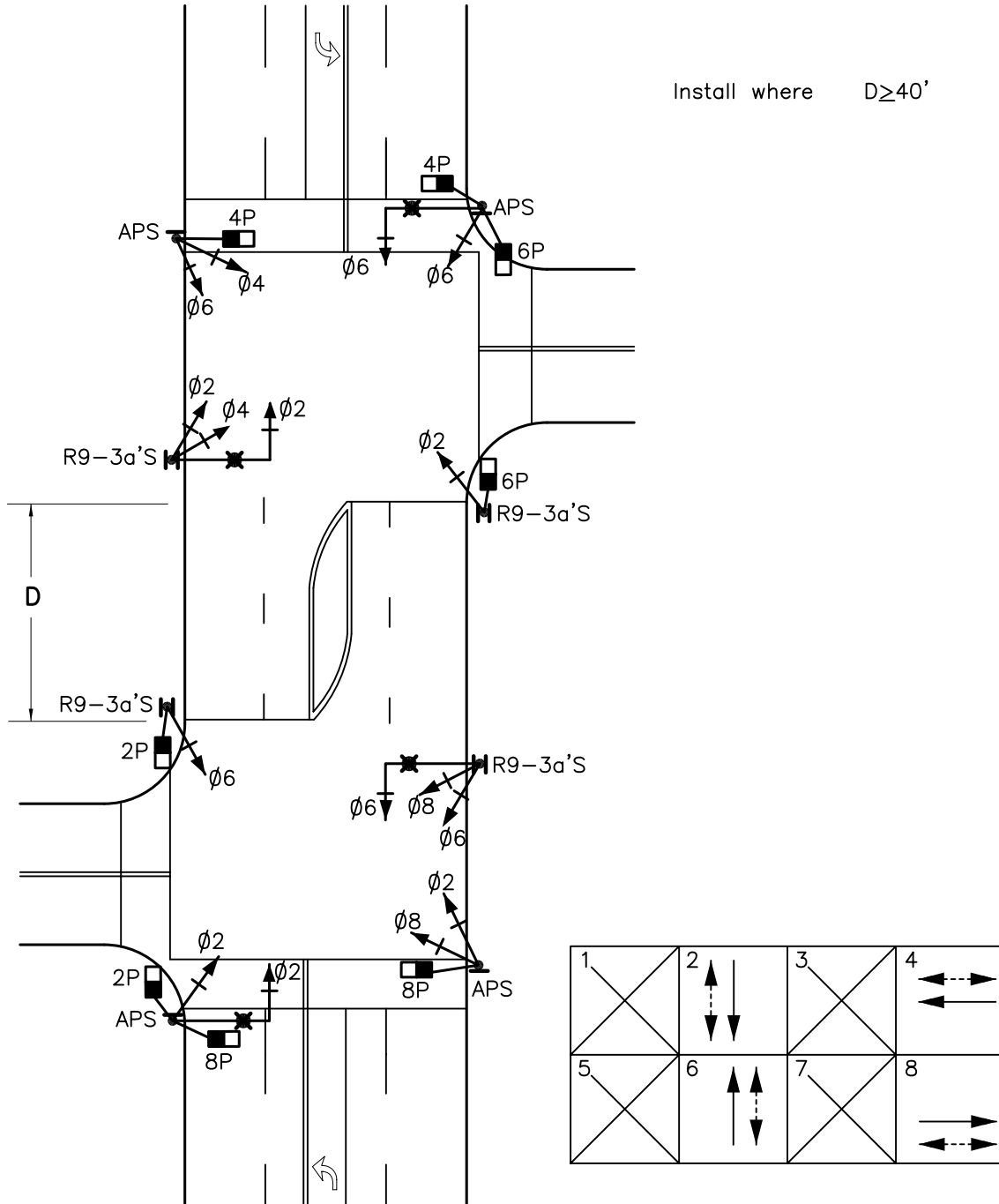

Left jogged Intersection
Interior Limit Lines

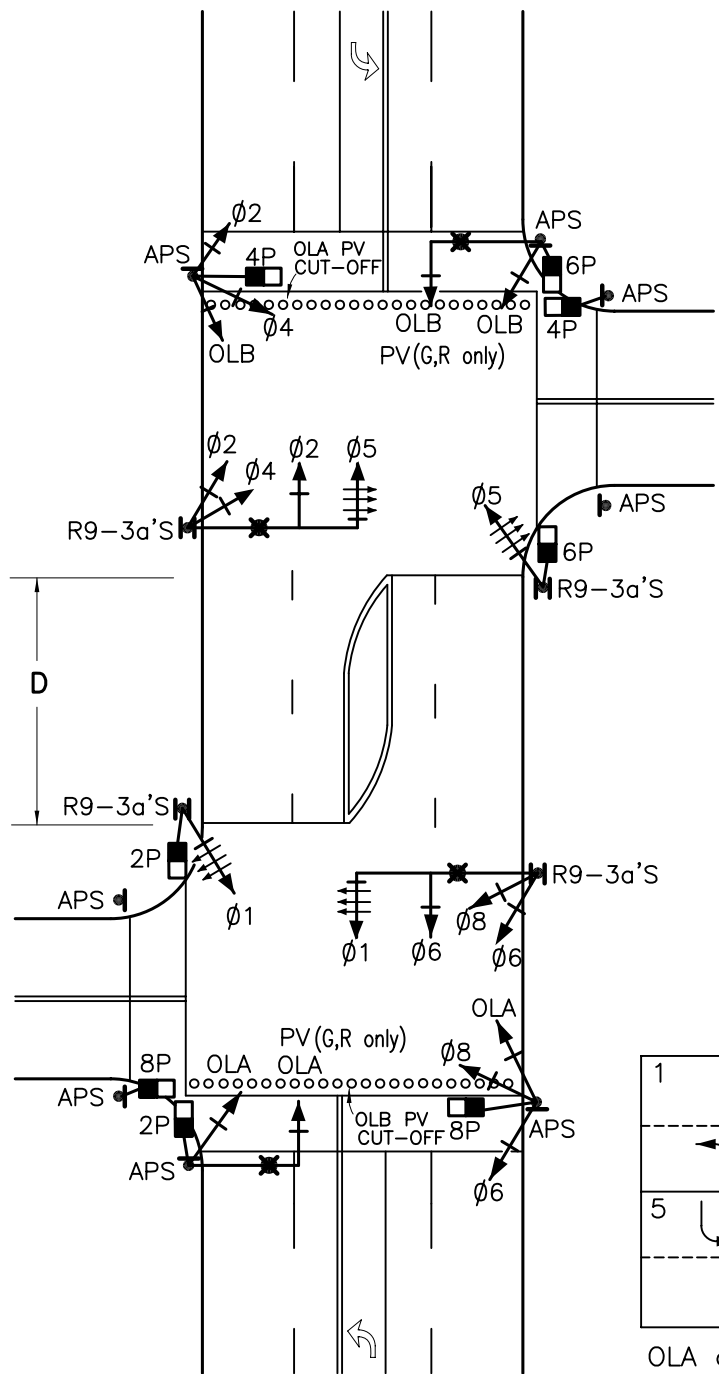

Install where:

- a) $40' \leq D \leq 200'$ and
- b) There have been 4 or more Right Angle accidents or 4 or more Left Turn accidents in a recent 12 month period at one of the intersections involving vehicles departing from the interior limit line.

Left jogged Intersection
Interior Limit Lines
Slot Clearance

1	2	3	4
	↓	↘	←
	↑	↙	←
5	6	7	8
↙	↑	↘	→
	↓	↙	→

OLA and OLB include slot clearance

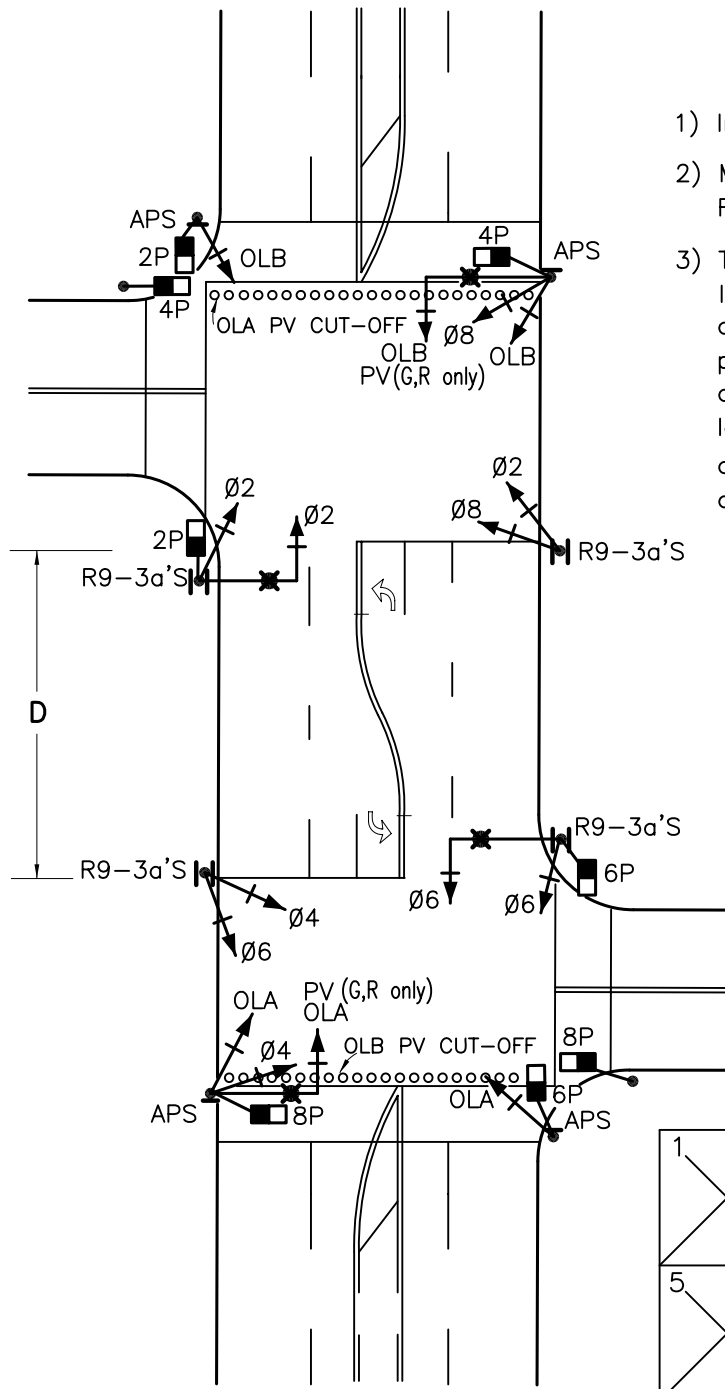

- 1) Install where $40' \leq D \leq 200'$
- 2) Mask only the Green and Red lenses of the PV heads.
- 3) The back-to-back left-turn lanes, as shown, are possible only where $D \geq 70'$. Where not possible, a left-turn lane in one direction, possibly with a left-turn restriction in the other direction, should be considered.

Right jogged Intersection
Interior Limit Lines

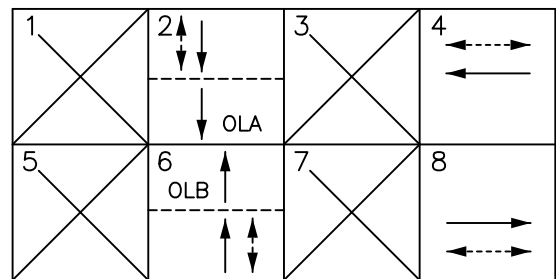

OLA and OLB include slot clearance

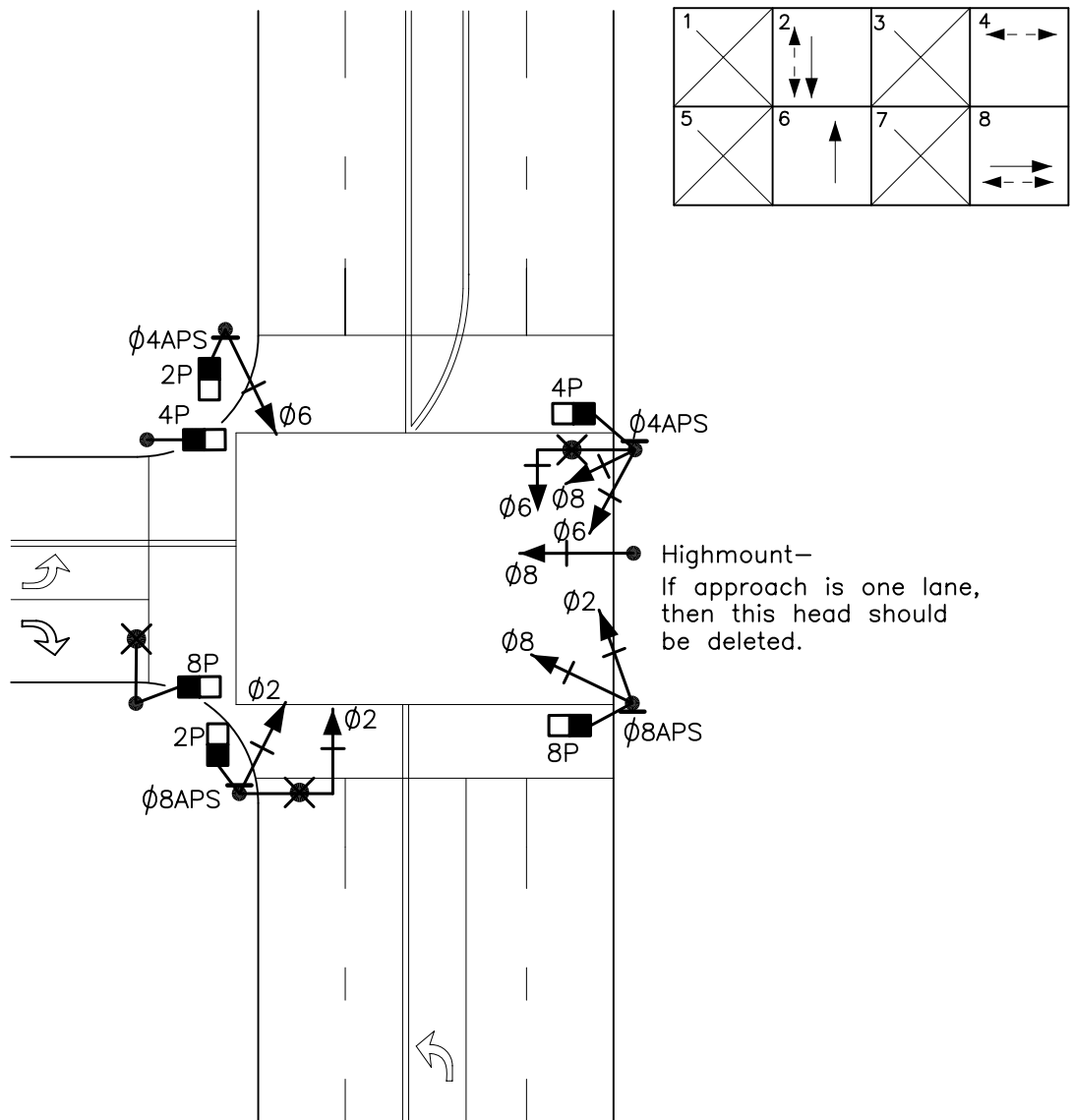

"T" Intersection

This drawing is not intended to show the required safety lighting design. Final lighting designs may not include the depicted mastarm lighting and likely will include other lighting locations not shown.

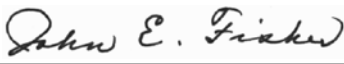
DWN	EC	6-10-10	Title	Typical Traffic Signal Layouts 1/8
CKD				
T. E.				
Sr. T. E.				
Pr. T. E.			CITY OF LOS ANGELES DEPARTMENT OF TRANSPORTATION	
Approved June 24, 2010			Drawing No.	
 for Rita L. Robinson, General Manager			S-101.0	

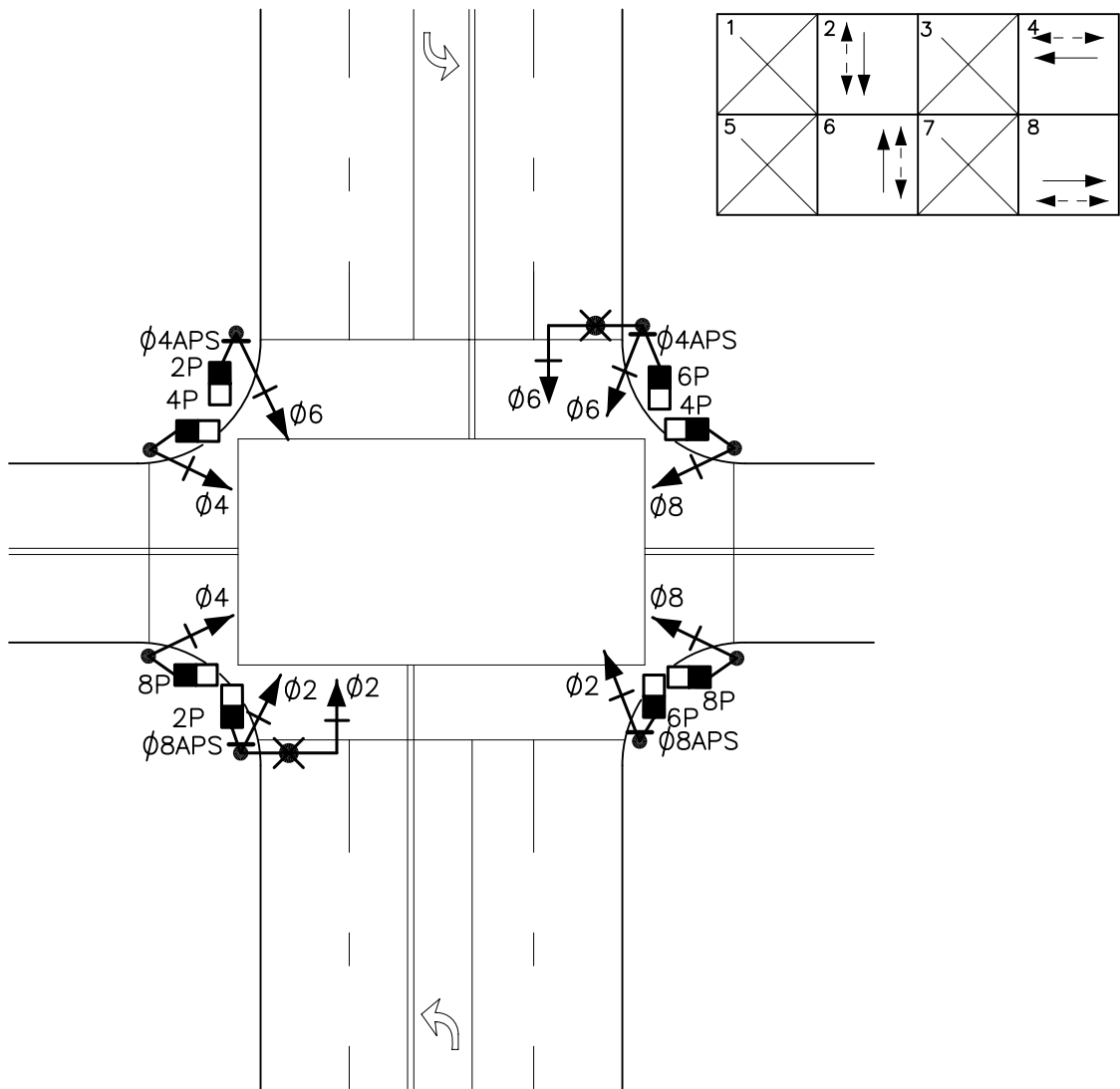

4-Leg Intersection

This drawing is not intended to show the required safety lighting design. Final lighting designs may not include the depicted mastarm lighting and likely will include other lighting locations not shown.

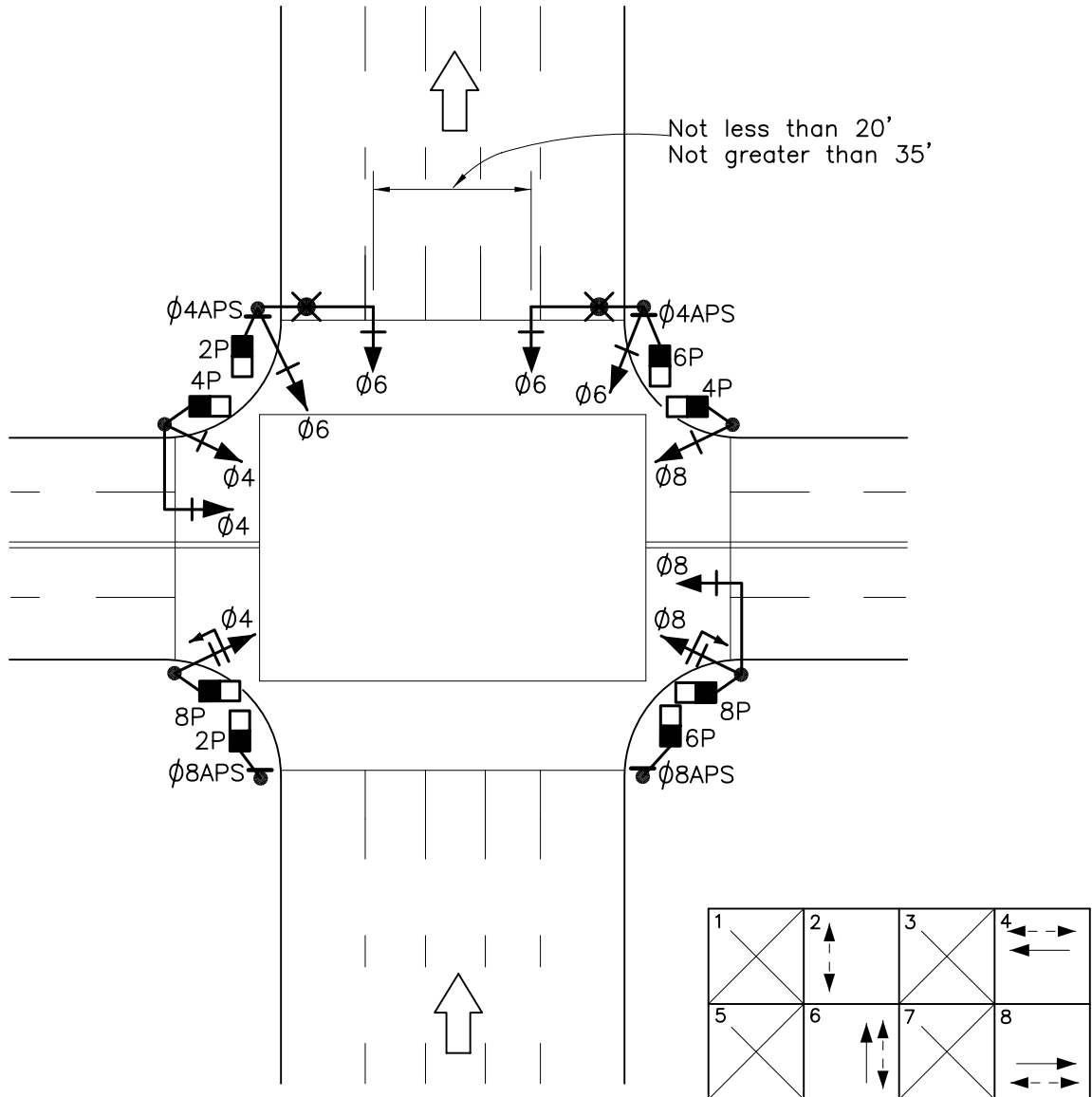

One Way Street

Notes:

1. For one-way streets with a roadway width less than 46 feet, a single mastarm signal head with the mastarm signal head placed within 5 feet of the center of the approach lane(s) should be installed.
2. This drawing is not intended to show the required safety lighting design. Final lighting designs may not include the depicted mastarm lighting and likely will include other lighting locations not shown.

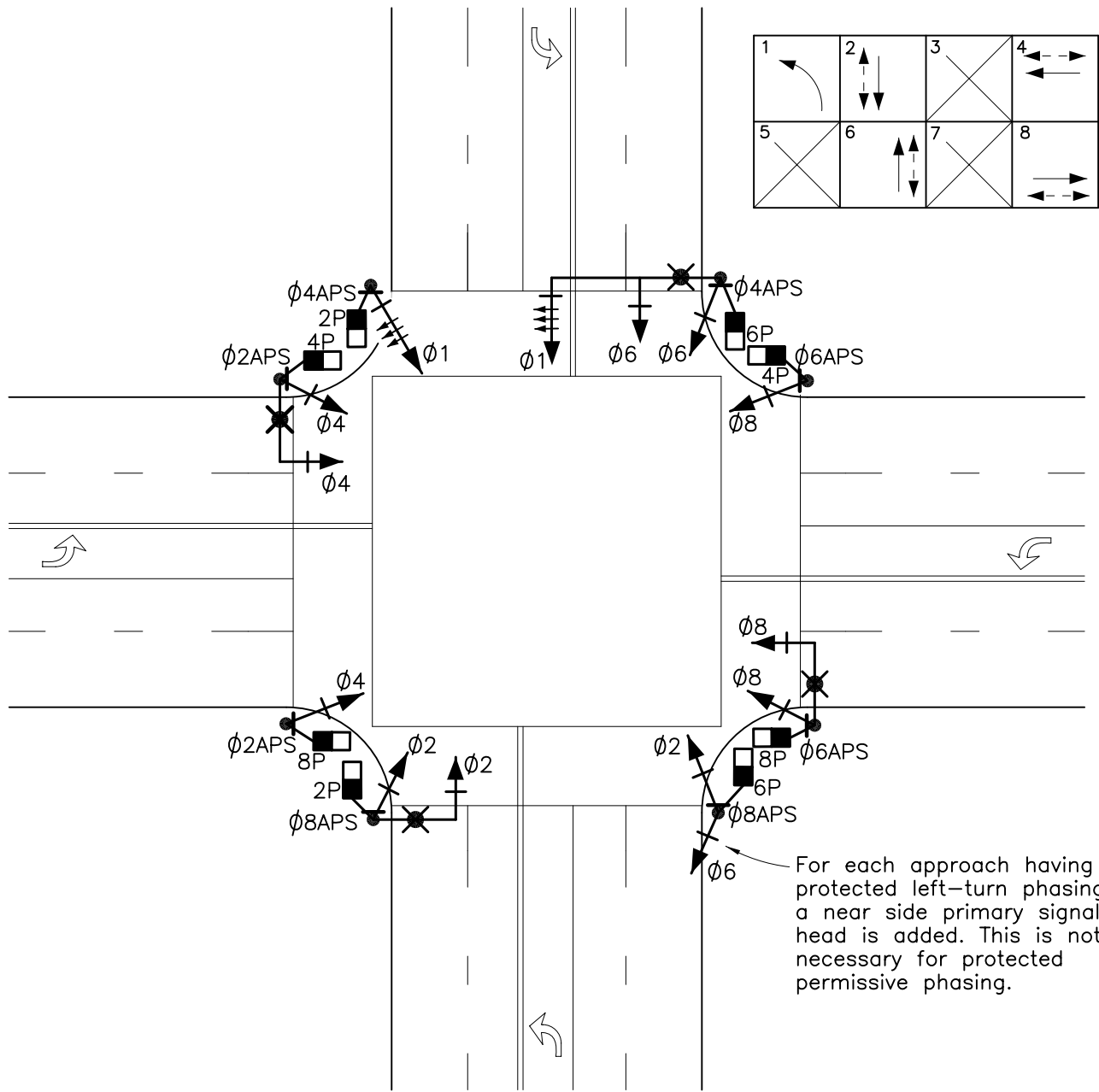

Left-Turn Phasing

Notes:

1. Protected left-turn phasing is shown. See S-65.0 for mastarm head placement for other types of left-turn phasing.
2. This drawing is not intended to show the required safety lighting design. Final lighting designs may not include the depicted mastarm lighting and likely will include other lighting locations not shown.

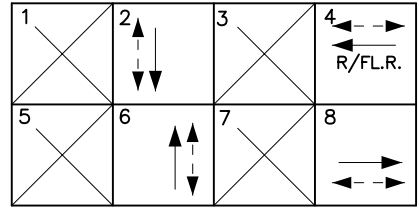
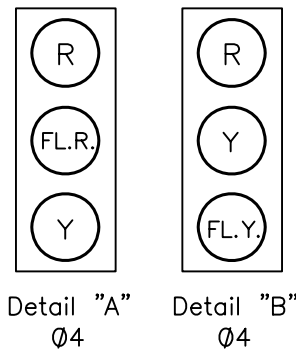
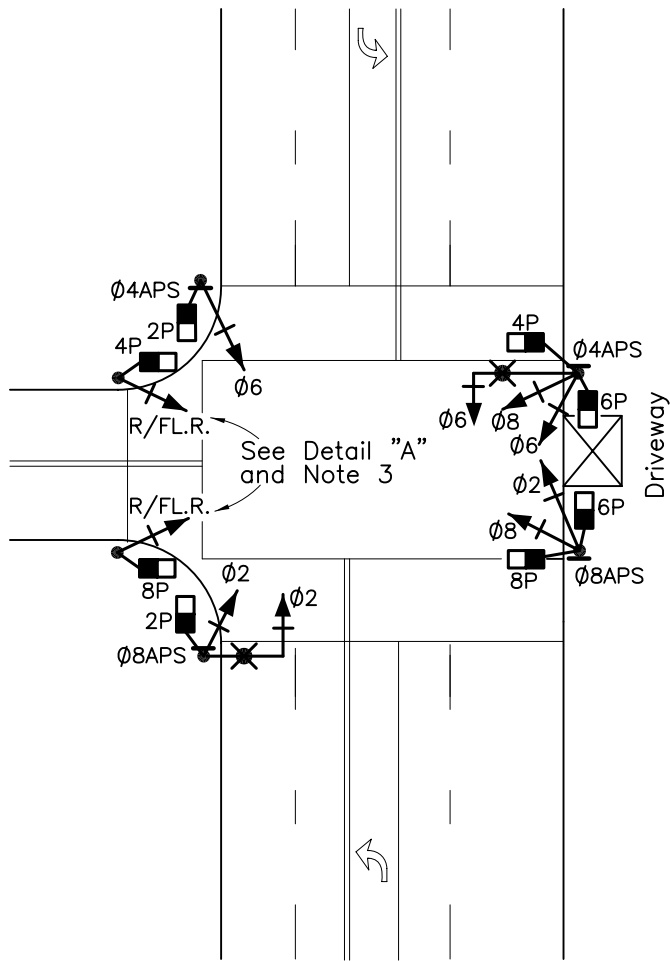

Where Ø8 traffic is moderately high or where the driveway is offset from the side street then opposed phasing should be considered.

Signalized Driveway

Notes:

1. This typical design is appropriate where a review of use has determined that the driveway should be signalized. Normally, this design would be used only where the driveway could not easily be reconstructed to be configured with curb returns and a "step down" design along the path of pedestrians. New development driveways with higher traffic volumes at intersections should be required to construct street like driveways with a layout for a "T" or 4-leg intersection, as appropriate.
2. This drawing is not intended to show the required safety lighting design. Final lighting designs may not include the depicted mastarm lighting and likely will include other lighting locations not shown.
3. Detail "B" may be used where visibility is good and a flashing yellow indication provides adequate control of driveway traffic.

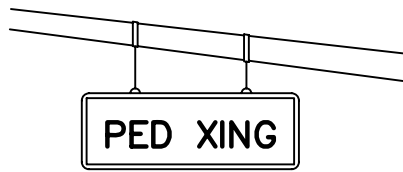

Black letters on yellow background
Detail "A"

X > 10'
See Note 3

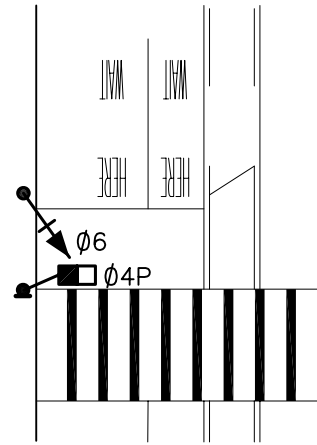

Detail "C"

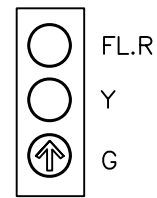
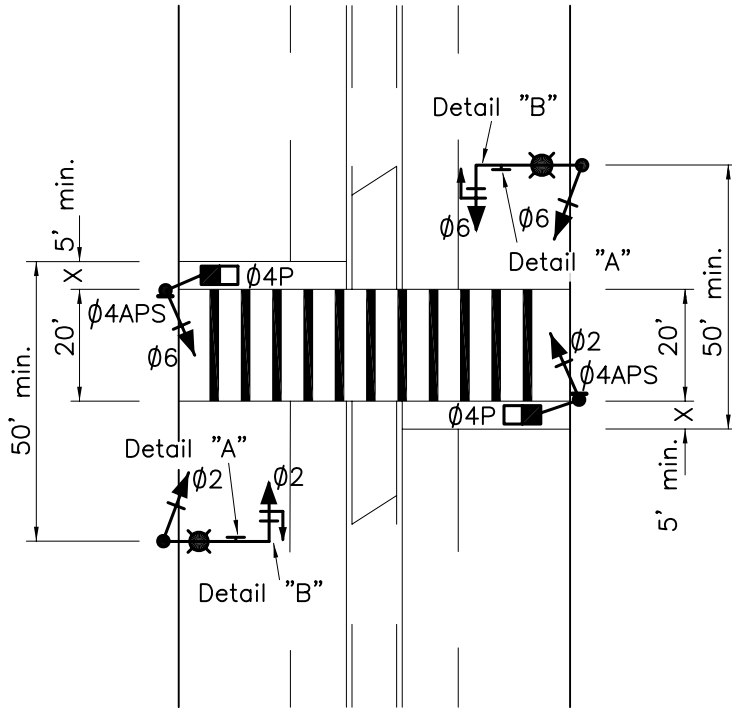

Detail "B"

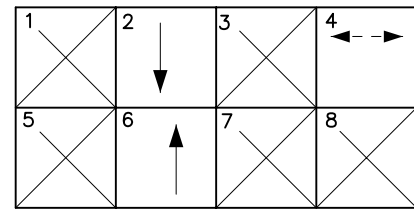

Signalized Midblock Crosswalk -Two Way Street

Notes:

1. Signal equipment should be combined with street lighting where feasible.
2. See S-493.0, Cases 13 & 14 for limit line locations. See S-481.0 for ladder crosswalk detail.
3. Where X is greater than 10', install a pole for the pedestrian head at the location shown, and a separate pole for the secondary vehicle head at the limit line, as shown in Detail "C".
4. This drawing is not intended to show the required safety lighting design. Final lighting designs may not include the depicted mastarm lighting and likely will include other lighting locations not shown.
5. During Phase 4 pedestrian sequence, Phases 2 & 6 receive a flashing red signal display.

Not less than 20'
Not greater than 35'

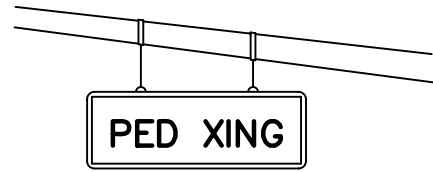
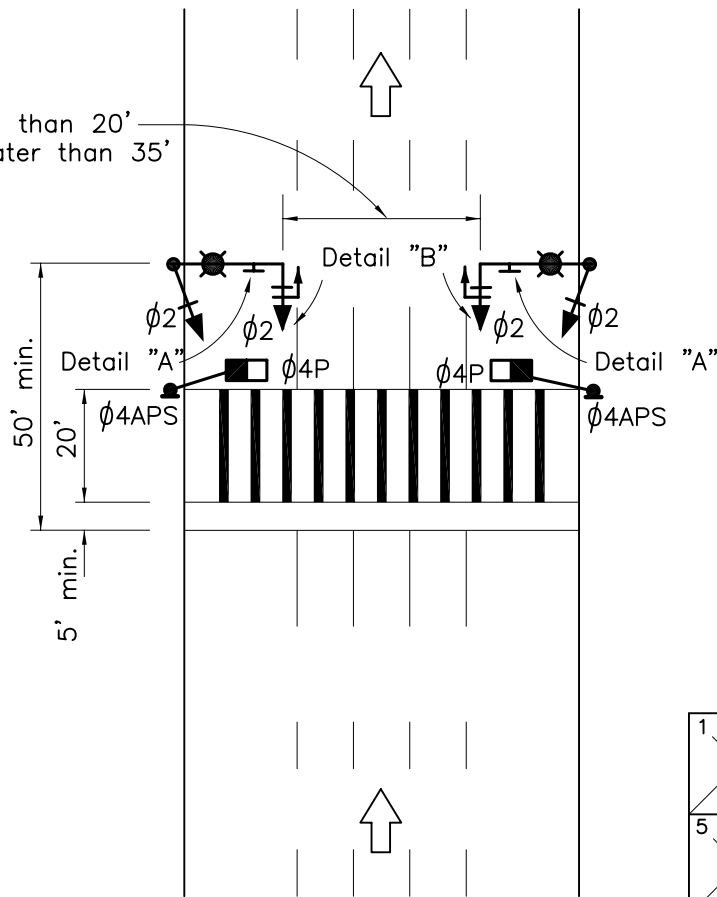

Black letters on
yellow background
Detail "A"

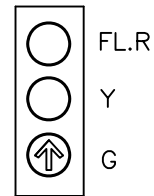

Detail "B"

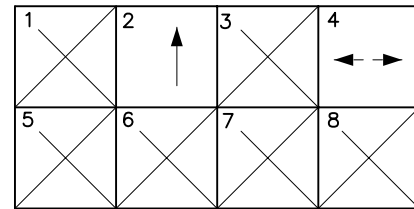

Signalized Midblock Crosswalk-One Way Street

Notes:

1. Signal equipment should be combined with street lighting where feasible.
2. See S-493.0, Cases 13 & 14 for limit line locations. See S-481.0 for ladder crosswalk detail.
3. For one-way streets with a roadway width less than 46 feet, a single mastarm signal head placed within 5 feet of the center of the approach lane(s) should be installed.
4. During Phase 4 pedestrian sequence, Phase 2 receives a flashing red signal display.

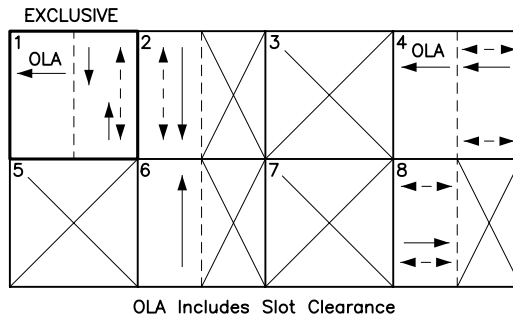
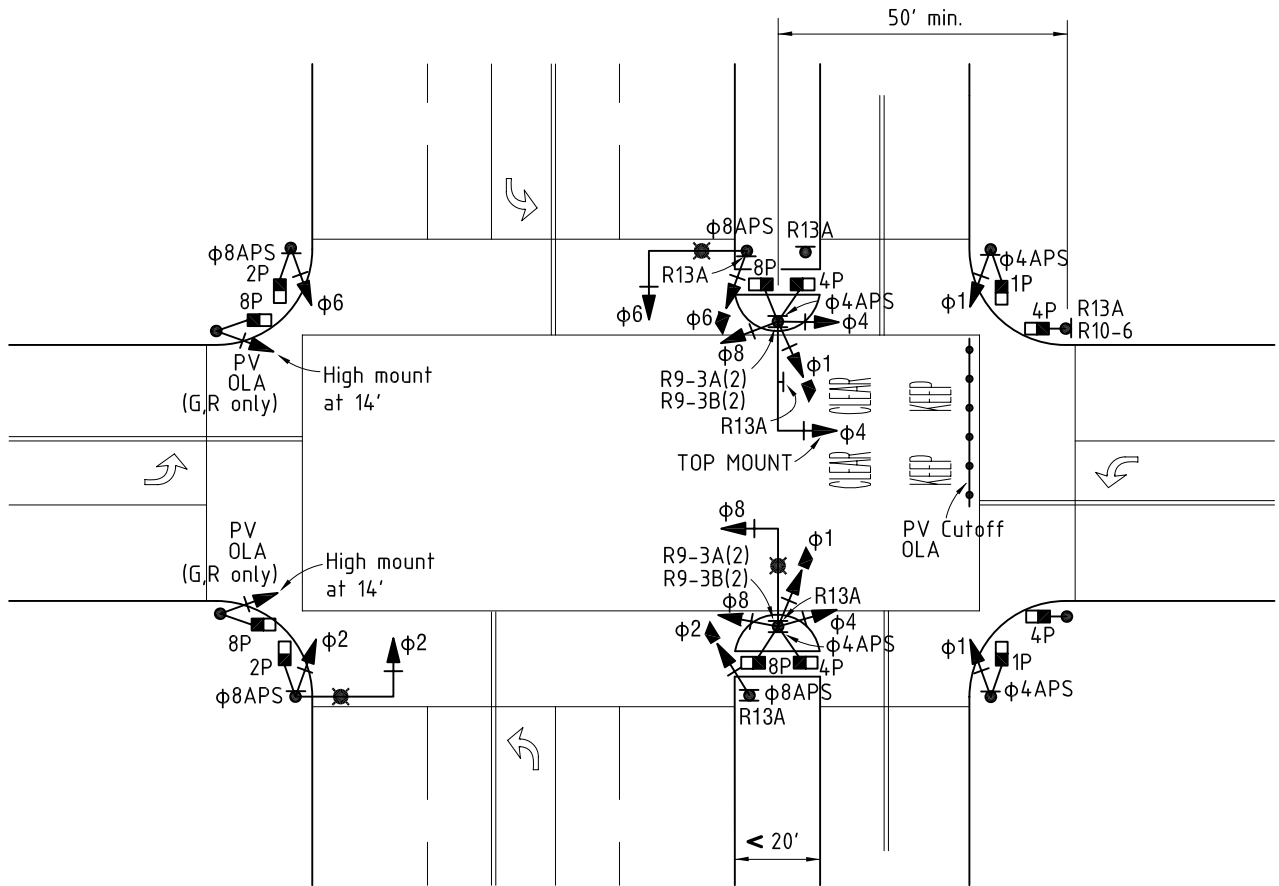

Intersection with Signalized Frontage Road

NOTES:

1. This drawing is not intended to show the required safety lighting design. Final lighting designs may not include the depicted mastarm lighting and likely will include other lighting locations not shown.
2. Mask only the green and red lenses of the programmed visibility (PV) heads.
3. To be used in Case 9 of S-493.0.

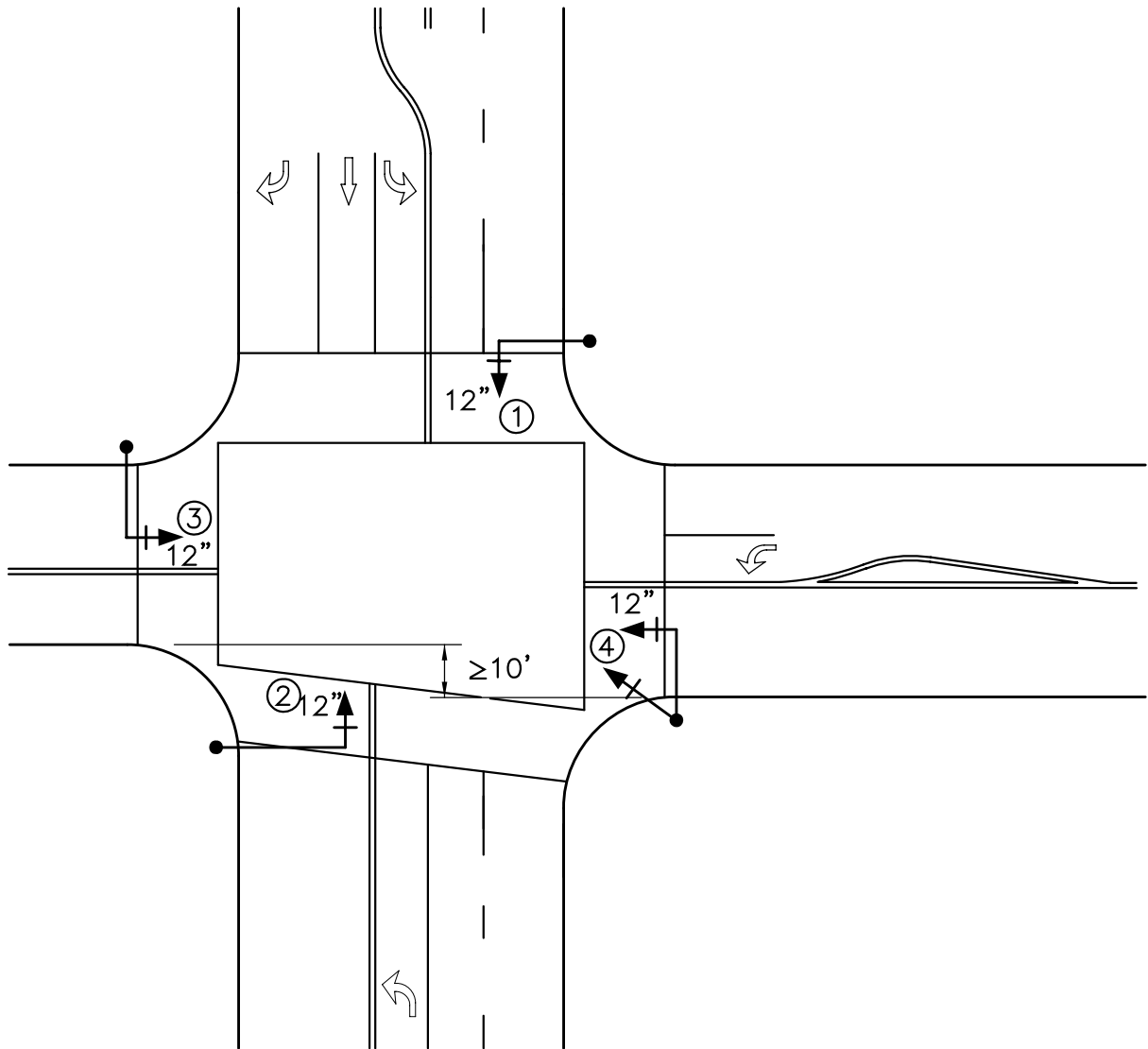

Provide mastarm heads where:

- . Approach has 2 or more striped lanes (mastarms ①, ② & ③).
- . Departure curb line has a 10' or greater offset to the right of approach curb line (mastarm ④), or a field investigation reveals the primary head location does not meet MUTCD Section 4B-12 visibility requirements.

DWN	MT	10-22-98	Title Mastarm Signal Head Installation Criteria	①/①
CKD				
T. E.				
Sr. T. E.			CITY OF LOS ANGELES DEPARTMENT OF TRANSPORTATION	
Pr. T. E.	JEF	11-2-98		
Approved		 Frances T. Banerjee, General Manager		11/13/1998 Drawing No. S-102.0

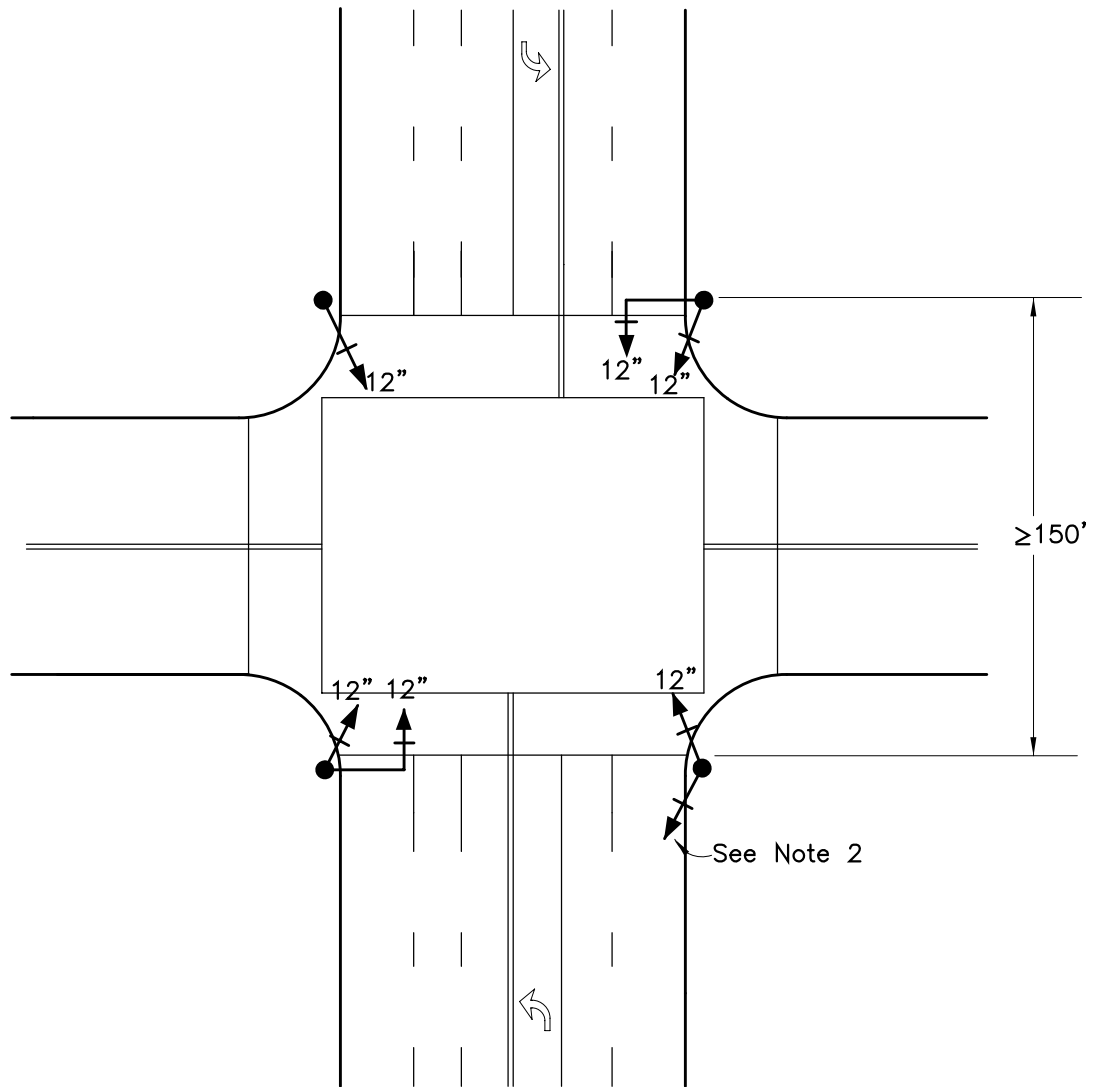

Notes:

1. All signal indications shall have 12" sections except as follows:
 - (a) Three-section near-side signals that are not high-mounted.
 - (b) Five-section near-side signals that have 12-inch arrows and three 8-inch circular indications.
 - (c) Signals that are exclusively used for bicycles at designated bicycle crossings.
 - (d) Far-side ground-mounted signals at closely spaced intersections (less than 300') where it is not practical to install visibility-limited signal indications.
2. Where the nearest signal is 150 feet or more beyond the stop line, a supplemental near-side indication shall be installed.

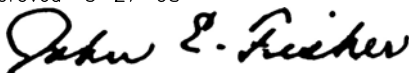
DWN	MT	02-28-08	Title Criteria for 12" Signal Heads	1/1
CKD	RAR	02-28-08		
T. E.	JV	3-20-08		
Sr. T. E.	JW	3-21-08		
Pr. T. E.				
CITY OF LOS ANGELES DEPARTMENT OF TRANSPORTATION				
Approved 3-27-08			Drawing No.	
 for Rita L. Robinson, General Manager			S-103.0	

- . Applications of Overhead Guide Signs: See Sheet 2
- . Overhead Sign Format Details: See Sheet 3
- . Arrow Styles and Specifications: See Sheet 4
- . Route Shield Sizes: See Sheet 5
- . W 61 Signs: See Sheet 5
- . Roadway Examples: See Sheets 6 & 7
- . Sign Formats: See Sheets 8~14
- . Application Notes: See Sheets 15 & 16

Approved		July 27, 2010	
 Rita L. Robinson, General Manager			
CITY OF LOS ANGELES DEPARTMENT OF TRANSPORTATION			
Overhead Guide Signing			1 / 16
T. E.	TC	Sr. T. E.	Pr. T. E.
DWN	MT 7-27-10	CKD	Dwg. No. S-418.6

APPLICATION OF OVERHEAD GUIDE SIGNS

General

These signs are desirable to provide a high degree of visibility to forewarn and direct motorists on multi-lane approaches of roadway access or lane assignment conditions that generally cannot be anticipated. Situations where overhead signs generally should be provided include:

- . Divergent arterial roadways
- . Skewed arterial approaches
- . Unshadowed left-turn lanes
- . Arterial grade separations, especially those which involve freeways
- . Priority lanes, such as bus and/or carpool lanes
- . Street name changes
- . End of one-way operation

While overhead signing should be used for the above situations, extenuating circumstances occasionally may suggest an alternative. Accordingly, roadside signing shall be used in the above situations where overhead signing is not used.

Divergent Arterial Roadways

Overhead signs are desirable because motorists cannot otherwise anticipate lane assignment and street name changes at the divergence. Where the intersecting street is not an arterial street and no lanes are entrapped onto it then overhead signing is not required. Also, where one of the arterial roadways has no change in horizontal alignment nor name and has no lanes that are entrapped onto the intersecting arterial roadway then no divergence exists and thus overhead signing is not required. See Signs A and B with related notes.

Skewed Arterial Approaches

Overhead signs are desirable because the deviation from right angles formed between the intersection legs can result in lane assignment ambiguity. See Signs C and D with related notes.

Unshadowed Left-Turn Lanes

Overhead signs are desirable on two-way streets so that motorists will readily recognize that the lane is entrapped and that there may be opposing traffic in the lane downstream. If there is a raised median then ground-mounted signing in the median may be adequate. See Signs B, C and D that display R3-5 signs with related notes and Signs S and U.

Arterial Grade Separations

Overhead signs are desirable because motorists cannot otherwise anticipate whether the connecting ramp figuration is on the left or right of the arterial approach. "Action" overhead signs show the immediate left-turn or divergent move necessary for access to the grade-separated facility. If there is a raised median then ground-mounted signing in the median may be adequate. "Action" overhead signs are not necessary for right turns or right-divergent moves, since "Lane Assignment" signs will direct motorists to the right lane(s) from where they can readily read roadside signing. See Signs E, F, G, H, H-Alternate, I, I-Alternate with related notes. "Lane Assignment" signs forewarn motorists as to which lanes of a multi-lane approach provide on-ramp access. Section 2D.45 of the California MUTCD requires "Lane Assignment" signs on multi-lane approaches to freeways. See Signs J, K, L, M and N with related notes.

Priority Lanes

Overhead signs are desirable for this rare regulatory condition which cannot otherwise be anticipated. See Signs O, P and Q with related notes.

Street Name Changes

Overhead signs are desirable at selected non-divergent locations and major junctions to advise motorists of the change in route name. selected locations would be near regionally-significant activity centers. See Sign R.

End of One-Way Operation

Overhead signs are desirable so that motorists in the opposing direction (on the two-way leg of the intersection) may readily recognize that they must turn left and/or right. See Signs S, T and U.

CITY OF LOS ANGELES DEPARTMENT OF TRANSPORTATION		
OVERHEAD GUIDE SIGNING		2 / 16
CKD.	SR. T.E.	PR. T.E.
DWN. M.T.	T.E.	S-418.6

OVERHEAD SIGN FORMAT DETAILS

Legend Size

The minimum size of letters on overhead signs is 8 inches upper case and 6 inches lower case. On streets with three or more approach lanes or with a posted speed limit of 40 miles per hour or greater 10.67 inch upper case and 8 inch lower case letters should be used.

Series E letter widths should be used, but in constrained situations Series C letter widths may be used.

Supplemental or clarifying wording on regulatory and guide signs (such as "ONTO BEVERLY DR", "200 FT" or "3 OR MORE") shall be 6 inch series D capital letters and numbers.

Lane Assignment wording ("RIGHT LANE", etc) shall be 6 inch Series D capital letters.

Cardinal directions shall have the first letter (N, S, E, W) larger so as to improve cardinal recognition. Where the general legend is 10.67 inches upper case and 8 inches lower case the cardinal direction should have 10 inch and 8 inch Series D letters. Where the general legend is 8 inches upper case and 6 inches lower case the cardinal direction should have 8 inch and 6 inch Series D letters.

The size of horizontal and vertical spacing should be equal to the height of the upper case letter. In constrained formats a minimum of one-half of these dimensions may be used. Division and border lines should be 1-1/2 inches wide.

See Sheets 4 and 5 for the sizes of arrows, route shields, and W61B(CA) and W61F(CA) signs.

Sign Size

The size of the sign is governed by the size of its elements. Sign software programs should be used to determine overall sign size.

Sign Structure

Fabrication of the sign from laminated, honeycomb panels using aluminum framing is shown in S-45.0. Cantilevered sign supports are shown in S92.2, S92.3, S98.0 and Plans S40N, S40P and S40Q of the State of California, Standard Plans.

Sign Retroreflectivity Material

White Legend: Diamond (DG III) or Type VIII

Black Legend: Non-reflective Vinyl

Red legend: EC Film

Green Background: Type III

White Background: Type III

Yellow Background: Type III

All signs are to have match component UV/Anti Graffiti film.

CITY OF LOS ANGELES DEPARTMENT OF TRANSPORTATION		
OVERHEAD GUIDE SIGNING		3 16
CKD.	SR. T.E.	PR. T.E.
DWN. M.T.	T.E.	S-418.6

Arrow Styles & Specifications

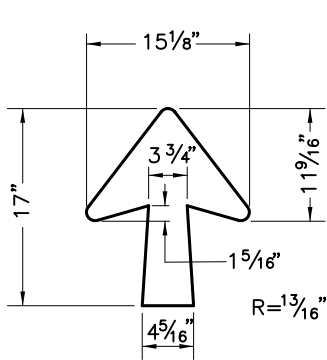

One Line

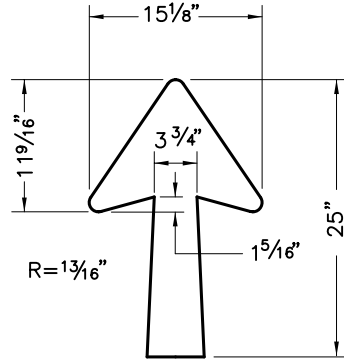

Two Line

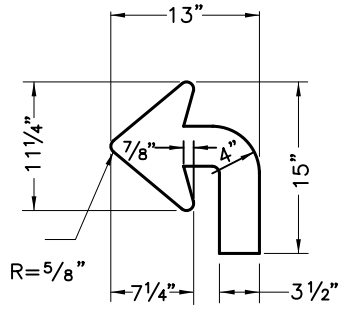

Advance Arrow

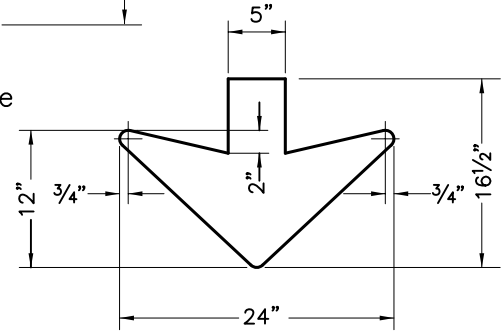

Down Vertical Arrow

Diagrammatic Arrows

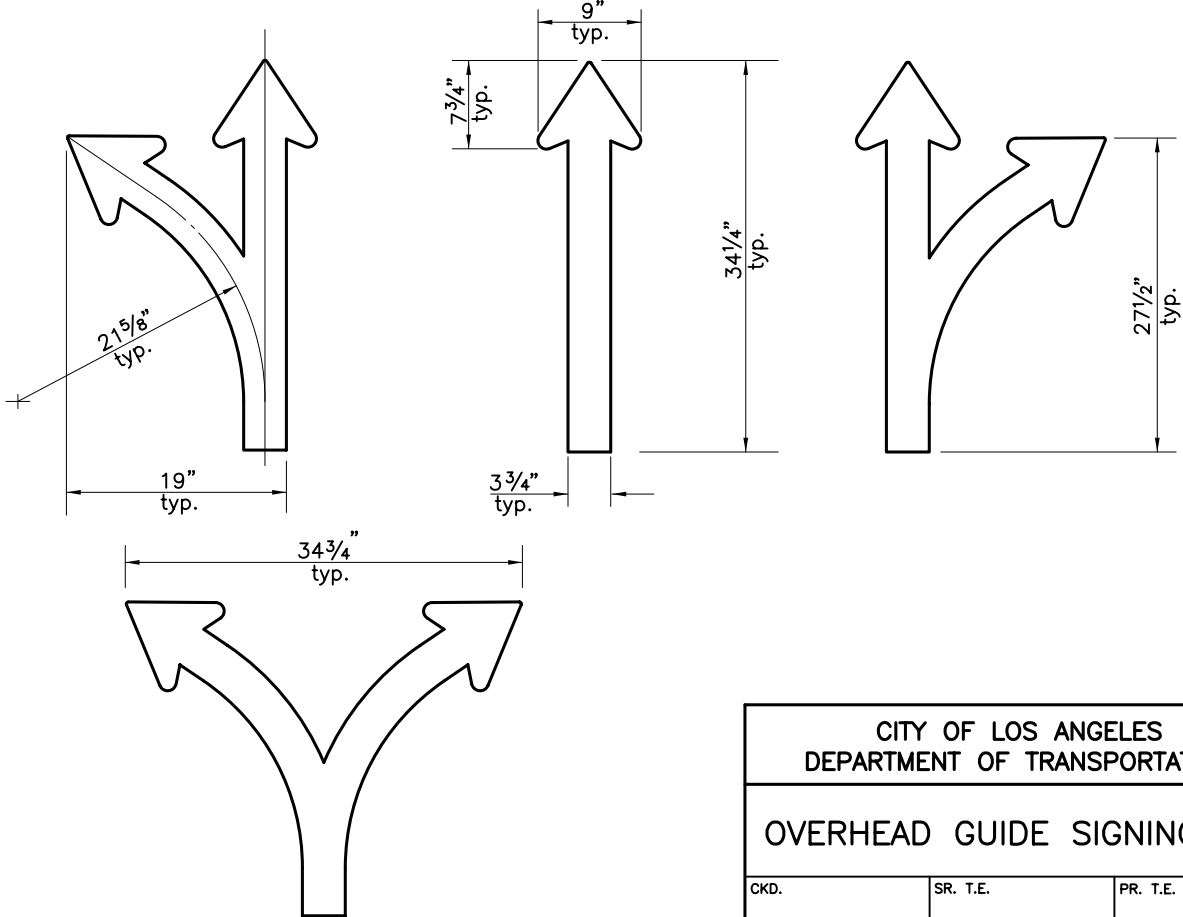

CITY OF LOS ANGELES
DEPARTMENT OF TRANSPORTATION

OVERHEAD GUIDE SIGNING

4
16

CKD.

SR. T.E.

PR. T.E.

DWN.

M.T.

T.E.

S-418.6

Route Shield Sizes

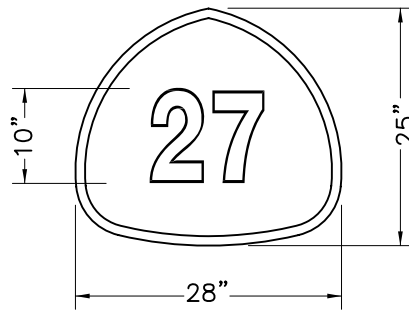
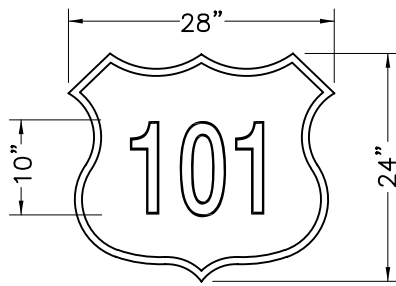

1 or 2 digits

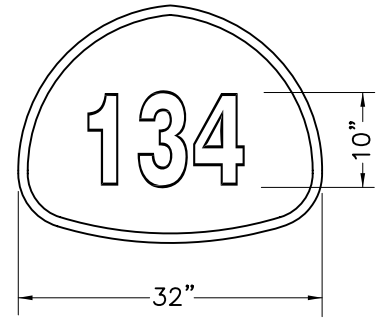

3 digits

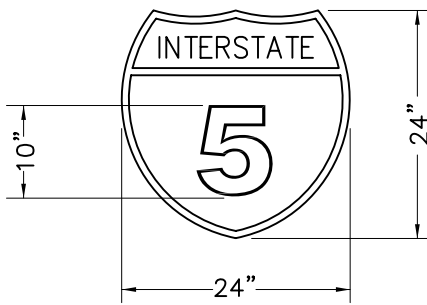

1 or 2 digits

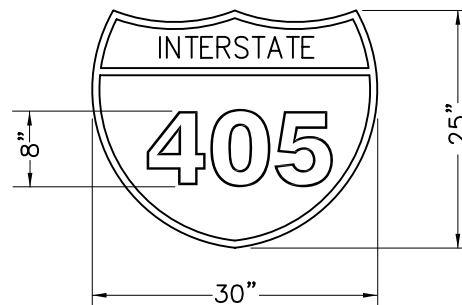

3 digits

W 61(CA) Signs

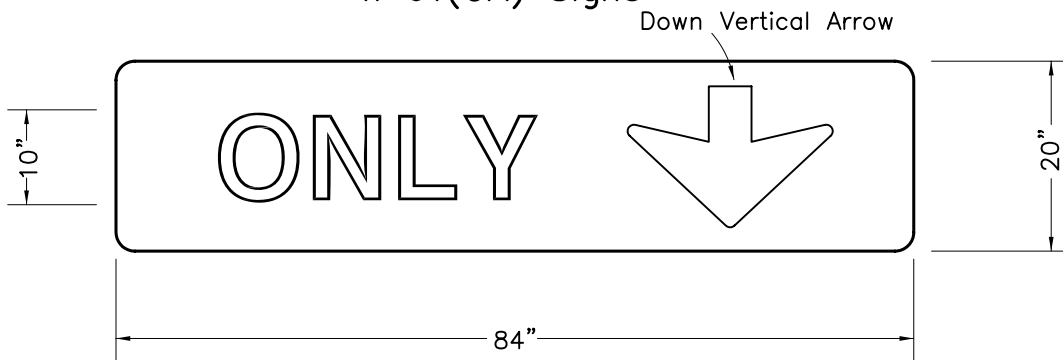

Yellow or White Background as per Note 4
W61F(CA)

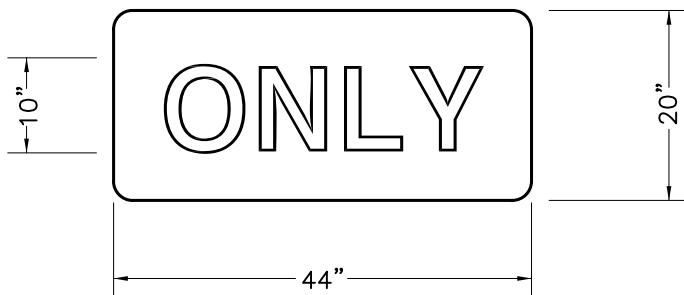

Yellow or White Background
as per Note 4
W61B(CA)

CITY OF LOS ANGELES DEPARTMENT OF TRANSPORTATION		
OVERHEAD GUIDE SIGNING		5 16
CKD.	SR. T.E.	PR. T.E.
DWN. M.T.	T.E.	S-418.6

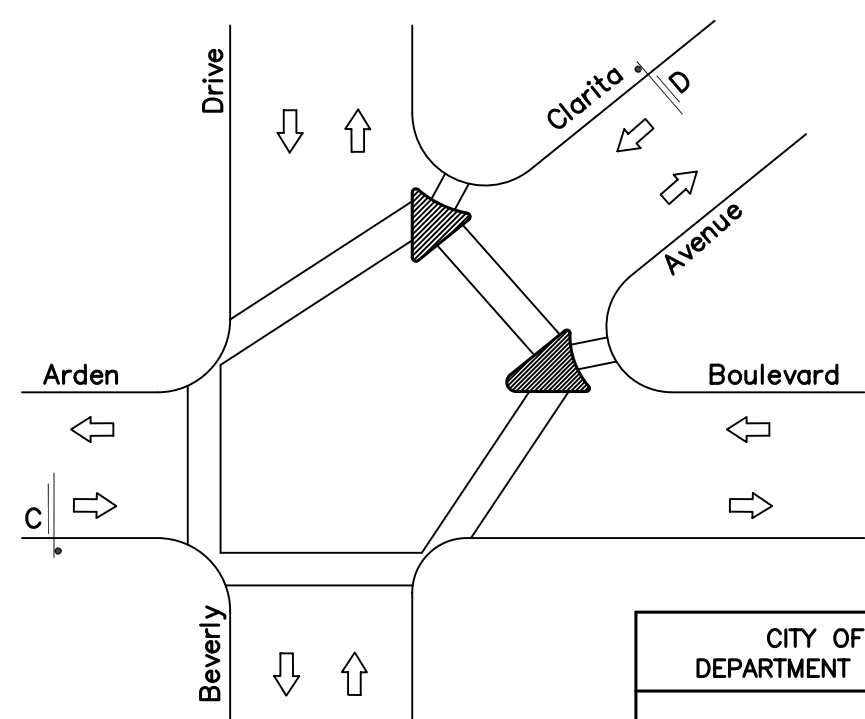
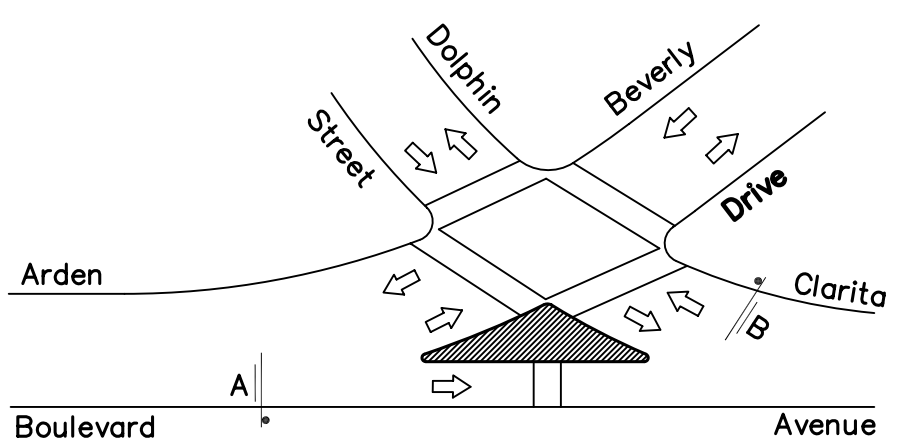
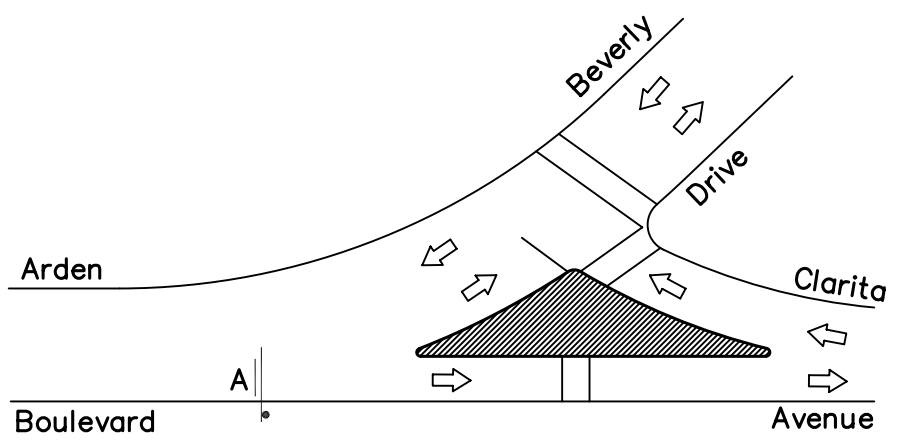

CITY OF LOS ANGELES DEPARTMENT OF TRANSPORTATION		
OVERHEAD GUIDE SIGNING		6 16
CKD.	SR. T.E.	PR. T.E.
DWN. M.T.	T.E.	S-418.6

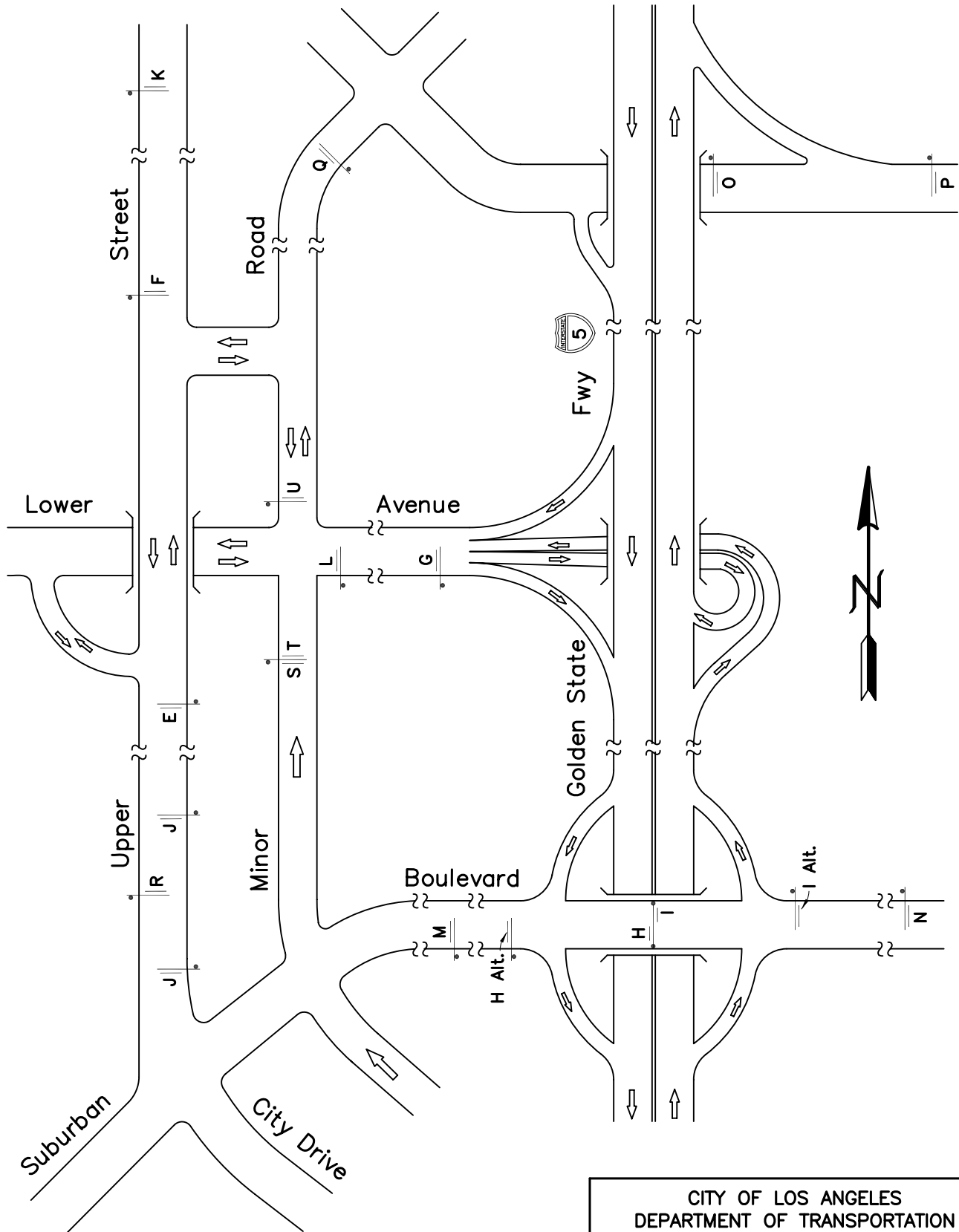

CITY OF LOS ANGELES
DEPARTMENT OF TRANSPORTATION

OVERHEAD GUIDE SIGNING 7 / 16

CKD.	SR. T.E.	PR. T.E.
DWN. M.T.	T.E.	S-418.6

Sign A (3 approach lanes shown)

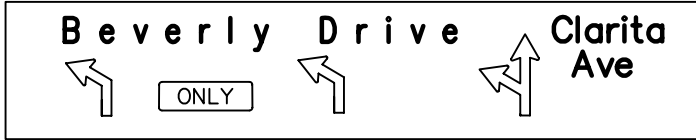

See Notes 1~5
Diagrammatic Arrows shown due to optional lane, as per Note 3.

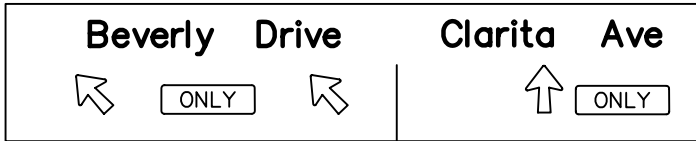

See Notes 1~5
Two-Line vertical and diagonal shown since optional lanes are not involved, as per Note 3.

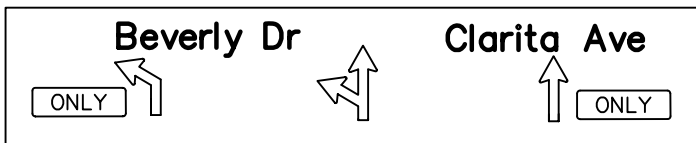

See Notes 1~5
Diagrammatic Arrows

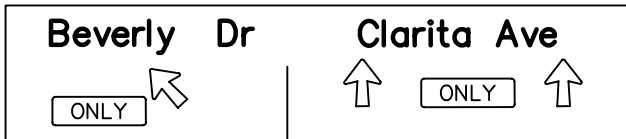

See Notes 1~5
Two-Line Arrows

Sign B (3 and 4 approach lanes shown)

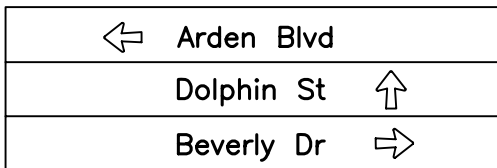

See Note 6
One-Line Arrows

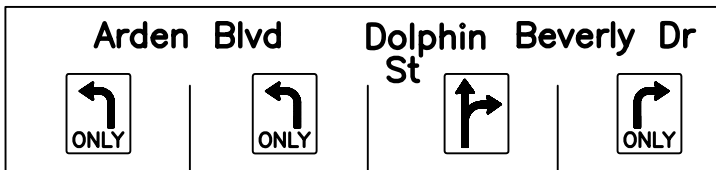

See Note 7
R3-5 and R3-6 shown, as per Note 7.

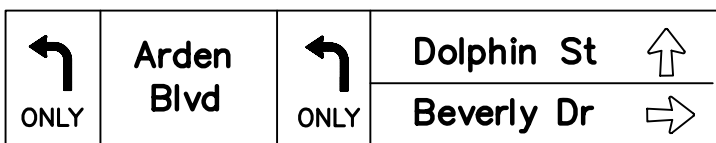

See Notes 6 and 7
One-Line Arrows

CITY OF LOS ANGELES DEPARTMENT OF TRANSPORTATION		
OVERHEAD GUIDE SIGNING		8 16
CKD.	SR. T.E.	PR. T.E.
DWN. M.T.	T.E.	S-418.6

Sign C (2 and more approach lanes shown)



See Notes 6 and 8
One-Line Arrows

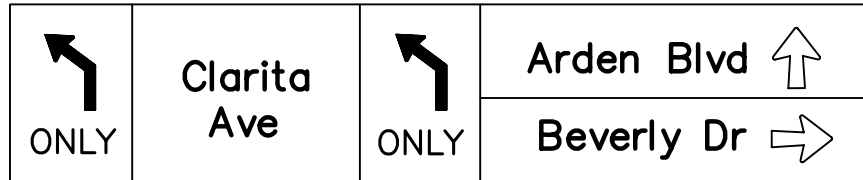

See Notes 6, 7, 8 and 9
One-Line Arrows

Sign D (3 approach lanes shown)



See Notes 7 and 9



See Notes 7 and 9

Sign E



See Notes 6
One-Line Arrow

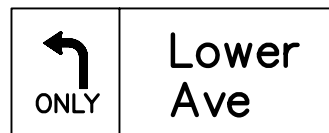

See Notes 6 and 7

CITY OF LOS ANGELES DEPARTMENT OF TRANSPORTATION		
OVERHEAD GUIDE SIGNING		9 16
CKD.	SR. T.E.	PR. T.E.
DWN. M.T.	T.E.	S-418.6

Sign F

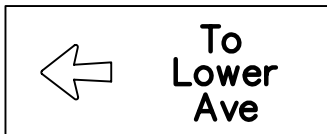

See Notes 6 and 10
One-Line Arrow

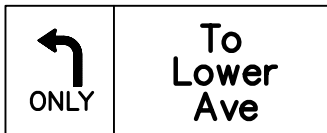

See Notes 6, 7 and 10

Sign G (2 approach lanes shown)

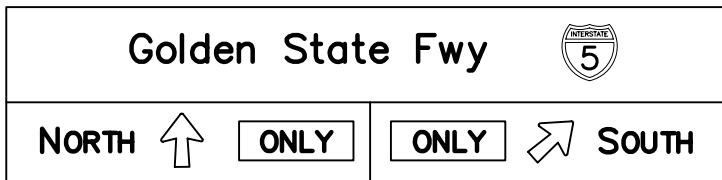

See Notes 2, 3, 4,
5 and 11
Two-line Arrows



See Notes 2, 3, 4,
5 and 11
Diagrammatic Arrows



See notes 2, 3, 4,
5 and 11
Diagrammatic Arrows

Sign H

See Notes 6 and 11
One-Line Arrow



See Notes 7 and 11
One-Line Arrow

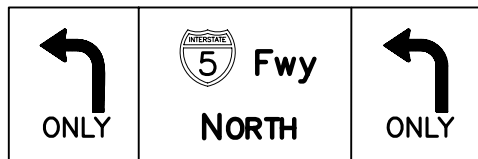

See Notes 7 and 11

CITY OF LOS ANGELES DEPARTMENT OF TRANSPORTATION		
OVERHEAD GUIDE SIGNING		10 16
CKD.	SR. T.E.	PR. T.E.
DWN. M.T.	T.E.	S-418.6

Sign H Alternate

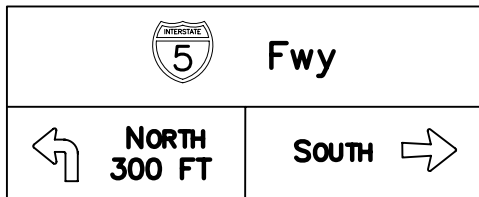

See Notes 11 and 12
Advance Arrow and One-Line Arrow

Sign I



See Notes 6 and 11
One-Line Arrow

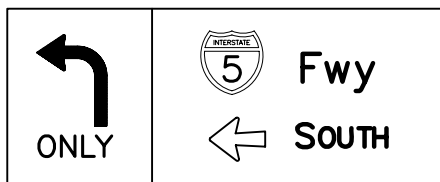

See Notes 7 and 11
One-Line Arrow

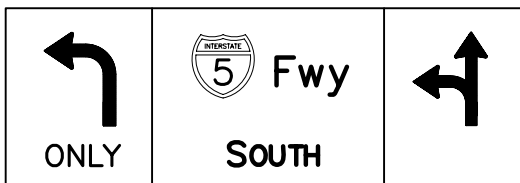

See Notes 7 and 11

Sign I Alternate

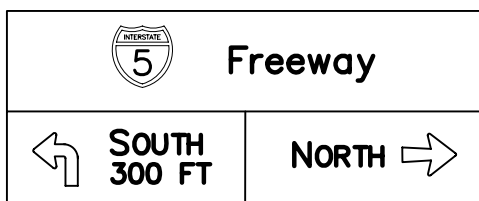

See Notes 11 and 12
Advance Arrow and One-Line Arrow

CITY OF LOS ANGELES DEPARTMENT OF TRANSPORTATION		
OVERHEAD GUIDE SIGNING		11 16
CKD.	SR. T.E.	PR. T.E.
DWN. M.T.	T.E.	S-418.6

Sign J

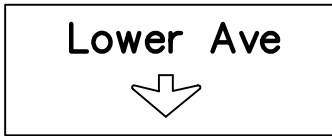

See Notes 13 and 14
Down Vertical Arrow

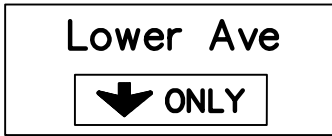

See Notes 13 and 14
Down Vertical Arrow for W61F sign,
as per Note 14



See Notes 13 and 14



See Notes 13, 14 and 15

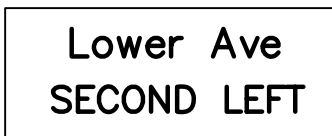

See Notes 13, 14 and 15

Sign K

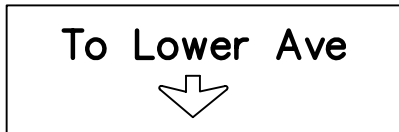

See Notes 10, 13 and 14
Down Vertical Arrow

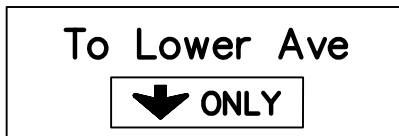

See Notes 10, 13, 14 and 15
Down Vertical Arrow



See Notes 10, 13 and 14

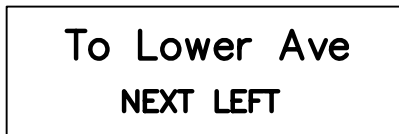

See Notes 10,
13 and 14

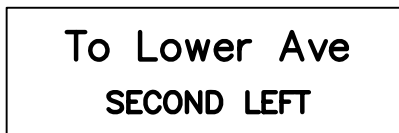

See Notes 10,
13 and 14

CITY OF LOS ANGELES DEPARTMENT OF TRANSPORTATION		
OVERHEAD GUIDE SIGNING		12 16
CKD.	SR. T.E.	PR. T.E.
DWN. M.T.	T.E.	S-418.6

Sign L (2 approach lanes shown)

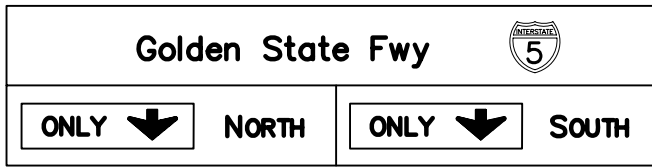

See Notes 11, 13, 14 and 15

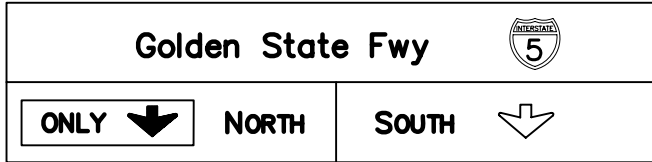

See Notes 11, 13, 14 and 15

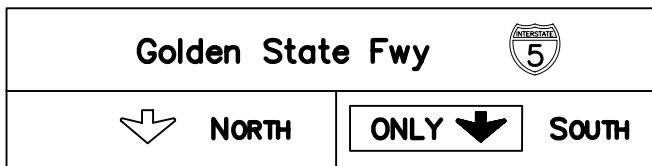

See Notes 11, 13, 14 and 15

Sign M (2 approach lanes shown)

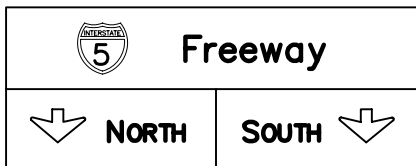

See Notes 11, 13 and 14



See Notes 11, 13 and 14

Sign N (2 approach lanes shown)

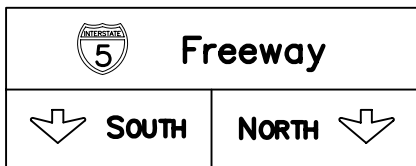

See Notes 11, 13 and 14

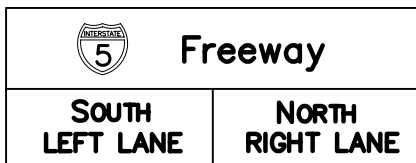

See Notes 11, 13 and 14

CITY OF LOS ANGELES DEPARTMENT OF TRANSPORTATION		
OVERHEAD GUIDE SIGNING		13 16
CKD.	SR. T.E.	PR. T.E.
DWN. M.T.	T.E.	S-418.6

Sign O

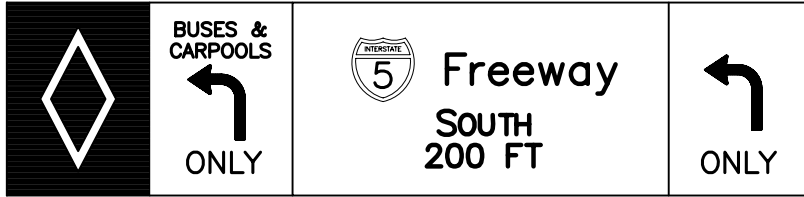

See Notes 7, 11, 12, 16, 17 and 18

Sign P



See Notes 3, 5, 11, 16, 17 and 18

Sign Q

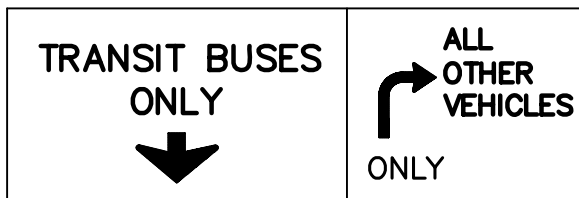

See Notes 7, 12, 17 and 18

Sign R

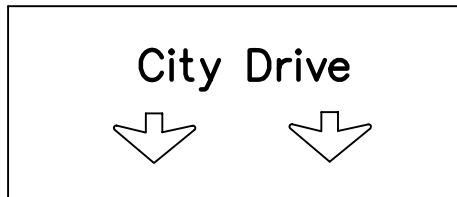

Vertical Down Arrow

Sign S (2 approach lanes shown)

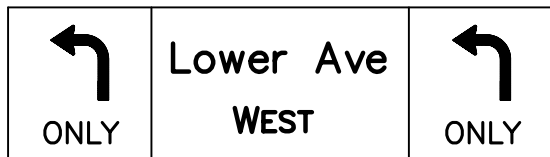

Sign T



Sign U (2 approach lanes shown)

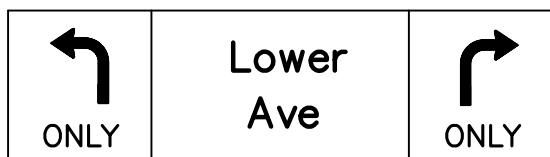

CITY OF LOS ANGELES DEPARTMENT OF TRANSPORTATION		
OVERHEAD GUIDE SIGNING		14 16
CKD.	SR. T.E.	PR. T.E.
DWN. M.T.	T.E.	S-418.6

Application Notes

1. At roadway divergences show all arterial street destinations, including those where the street name does not change. This is necessary because sometimes the street name continues on the left leg, sometimes on the right leg and sometimes diverges into two different names.
2. At roadway divergences with two or more approach lanes, utilize elephant track striping as per S-491.0.
3. At roadway divergences use Two-Line Vertical and Diagonal Arrows (with flared tails) over each applicable lane where optional lanes are not involved. However, where optional lanes are involved use Diagrammatic (non-flared) Arrows over each applicable lane in order to better convey the optional lane use.
4. Use the black on yellow "W 61B(CA)" plates to forewarn of the entrapped lane or divergence ahead. However, where the point of divergence is less than 200 feet downstream from the overhead sign, use R3-5 and R3-6 signs to regulate lane assignment.
5. Position arrows as close as practical over the middle of the applicable lanes and position the applicable arterial street destinations preferably above or immediately adjacent to appropriate arrow heads, as space permits. Vertical lines may be shown to distinguish lane groups.
6. Use the single or stacked line destination format in advance of intersections where entrapped turn lanes are not involved. List street and destination names in the following vertical order from the top, associated with the following directional one-line arrows: diagonal-vertical left, horizontal left, diagonal down left, vertical, diagonal-vertical right, horizontal right, and diagonal down right. Show left arrows to the left of the legends and vertical and right arrows to the right of the legends. Show vertical arrows to the left of the legends when the other destinations have right arrows, and to the right when the other destinations have left arrows.
7. At intersections where unshadowed (entrapped) turn lanes or interior optional lanes are involved use R3-5 and R3-6 signs positioned as close as practical over the middle of the applicable lanes.
8. Use the customized R3-2 sign where protected-only phasing is provided for one but not both of the possible left turns, such as the diagonal left-turn but not the sharper left-turn shown.
9. On the diagonal approach of a five-legged intersection the striping can be designed so that the through move is directed to either the right leg or left leg. The combination of striping and overhead signing should be coordinated to clarify and reinforce the intended operation. The first case shows two lanes directed to westbound Arden Boulevard, while the second shows two lanes directed to southbound Beverly Boulevard. Note that some secondary destinations requiring more than a ninety degree turn from an optional lane are not shown, due to space limitations.

CITY OF LOS ANGELES DEPARTMENT OF TRANSPORTATION		
OVERHEAD GUIDE SIGNING		15 / 16
CKD.	SR. T.E.	PR. T.E.
DWN. M.T.	T.E.	S-418.6

10. Where the destination roadway must be accessed via another named roadway the name should be preceded with the word, "To". Ground mounted trailblazer signs should be provided to direct motorist in advance of every decision point enroute to the destination roadway.

11. Where a freeway on-ramp is within one mile of a freeway-to-freeway interchange, the full freeway name should be shown followed by the appropriate route shield and number. However, in constrained situations the full freeway name may be deleted. In all other situations the appropriate route shield and number followed by the word, "Fwy" or "Freeway" is sufficient.

12. Use the Advance Arrow and "XXX FT" legends where there is an intervening roadway 100 feet or less upstream of the overhead sign.

13. Lane Assignment signs should be provided 600 to 1300 feet upstream of turns or divergences associated with grade separations.

14. For Lane Assignment signs use the Down Vertical Arrow format where there is an entrapped turn lane or where it is possible to position arrows over each of the applicable lanes. They should be placed as close as practical over the middle of each lane. Where this is not possible use the "LEFT (RIGHT) LANE" or "NEXT LEFT (RIGHT)" format. The "NEXT LEFT (RIGHT)" message may be used only where there is no intervening intersection. The "SECOND LEFT (RIGHT)" message may be used instead of "NEXT LEFT (RIGHT)" where there is close spacing between intersections.

15. The black-on-yellow "W61F(CA)" sign is used for advance warning of a trap lane, per S-491.0.

16. The sign panel pertaining to the bus and carpool lane shall have a black legend on a white background and the diamond shall be white legend on a black background.

17. See S-487.0 for exclusive bus lane striping.

18. For exclusive lanes where two-person carpools are allowed it is not necessary to identify the required vehicle occupancy. Other required occupancies shall be identified with and below the diamond symbol.

CITY OF LOS ANGELES DEPARTMENT OF TRANSPORTATION		
OVERHEAD GUIDE SIGNING		16 16
CKD.	SR. T.E.	PR. T.E.
DWN. M.T.	T.E.	S-418.6

Notes:

1. This standard plan supplements Table 1 of Section 521, pertaining to restricted sight distance which justifies protected left-turn phasing at signalized intersections.
2. Motorists require both an acceptable gap in opposing traffic and sufficient sight distance in order to execute permissive left turns. Studies have shown that the value of an acceptable gap is equal to $(5.0 + 0.5n)$ seconds of travel time, where "n" is the number of opposing through lanes. Sufficient sight distance is the distance associated with an acceptable gap, or the gap time multiplied by the design speed. The design speed for opposing through traffic is five miles per hour above the posted or *prima facie* speed limit. However, where there is restrictive horizontal or vertical alignment the design speed is five miles per hour above the posted advisory speed. See Table 1.

Table A: Minimum Sight Distance Requirements for Permissive Left Turns, * ft (rounded)

Speed Limit or Advisory Speed, mi/hr	Minimum Sight Distance Requirements, * ft (rounded)			
	5.5 sec 1 lane	6.0 sec 2 lane	6.5 sec 3 lane	7.0 sec 4 lane
15	165	180	195	210
20	205	220	240	260
25	240	260	290	310
30	280	310	330	360
35	320	350	380	410
40	360	400	430	460
45	400	440	480	510
50	440	480	520	570
55	480	530	570	620

*Based on the speed limit or advisory speed plus 5 mi/hr

3. Several types of sight distance restrictions can occur. Permanent type restrictions, due to horizontal curvature, vertical alignment or physical obstructions cannot be readily overcome. Where the sight distances for permanent type restrictions are less than that shown in Table A, and left turns are allowed then protected left-turn phasing is required. See Figures 1, 2 and 3 which illustrate these types of restrictions.
4. Sight distance also can be restricted due to opposing left turn vehicles at locations where left turn lanes are negatively offset. Where the opposing left turn demand is light it tends to be accommodated during the same signal cycle of arrival. In this case, left turn motorists would be afforded adequate sight distance to execute left turns at some point during the green or yellow after opposing left turn motorists clear. Thus, protected left turn phasing would not be necessary. See Figure 4. However, where an opposing left turn queue is frequent and persistent and the sight distances are less than those shown in Table A then left turn motorists are not afforded an opportunity to turn with adequate sight distance. In this case, island removal with restriping or protected left-turn phasing is necessary and required. See Figure 5.
5. A unique situation occurs with negatively offset left turn lanes in combination with a right horizontal curve. As illustrated in Figure 6, left turn motorists can see opposing through traffic both upstream from the front and downstream from the back of a left turn queue. However, motorists cannot continuously see downstream from the front of the queue. If the required sight distance is at a point which is not obstructed by the opposing queue then protected left turn phasing is phasing would not be necessary. However, where the required sight distance is at a point which is obstructed by the opposing queue then visibility is inadequate for left turning decisions and protected left turn phasing is required.

APPROVED		12 / 26 / 2000	
 Frances T. Banerjee, General Manager			
CITY OF LOS ANGELES DEPARTMENT OF TRANSPORTATION			
Restricted Sight Distance Criteria for Protected Left-Turn Phasing			1 7
CKD.	SR. T.E. TLJ	PR. T.E.	GO
DWN. MT	T.E.	S-497.0	

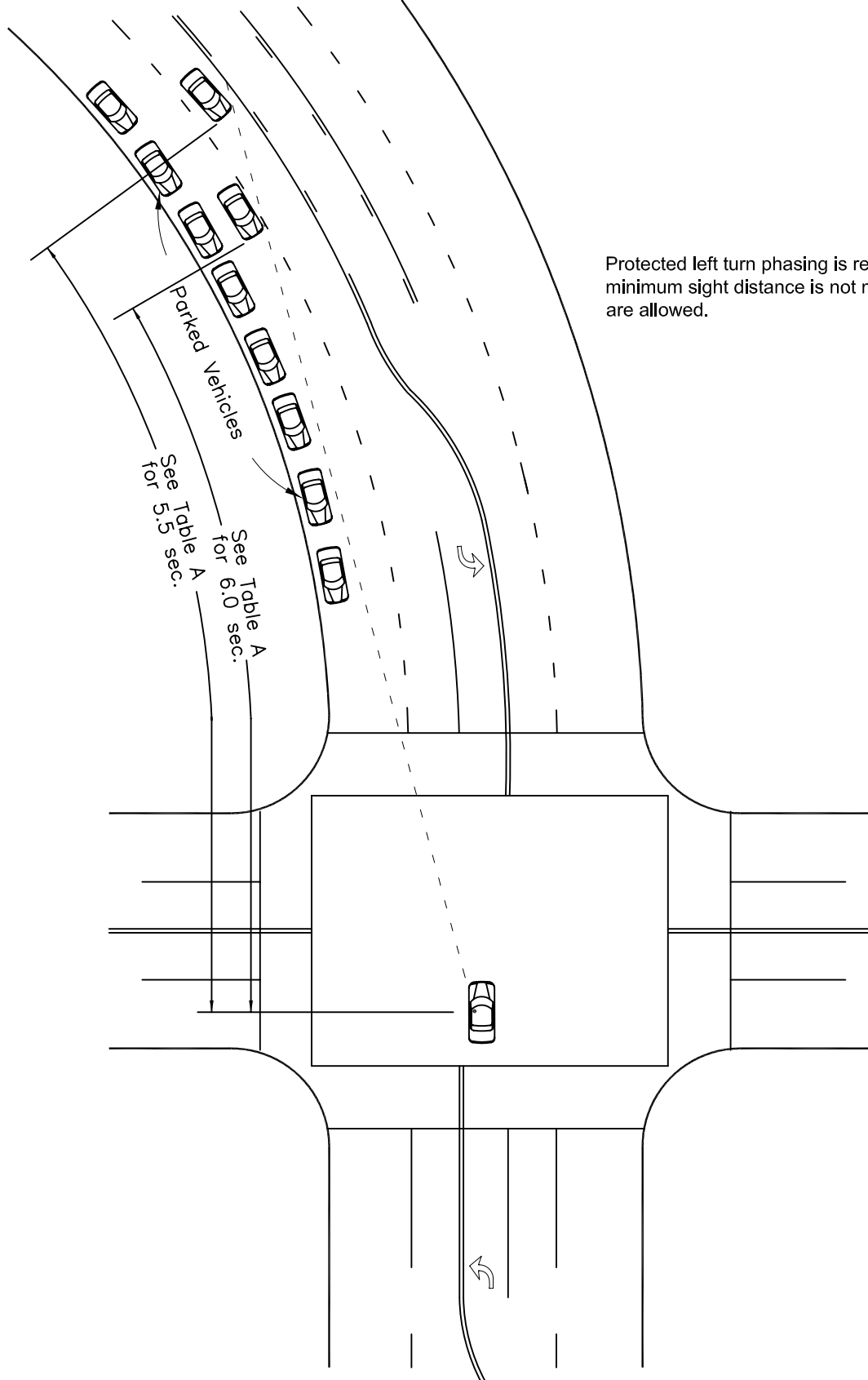

Protected left turn phasing is required if any minimum sight distance is not met and left turns are allowed.

Example of Restricted Sight Distance Due To Left Horizontal Curvature

Figure 1

<p>CITY OF LOS ANGELES DEPARTMENT OF TRANSPORTATION</p>	<p>Title Restricted Sight Distance Criteria for Protected Left-Turn Phasing</p>	<p>Drawing No. S-497.0</p>	<p>2 7</p>
---	---	---------------------------------------	----------------

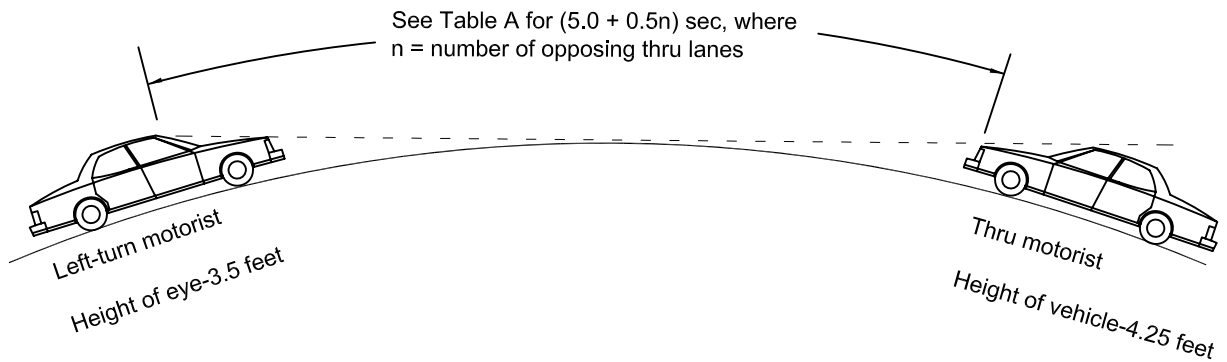

Protected left turn phasing is required if any minimum sight distance is not met and left turns are allowed.

Example of Restricted Sight Distance Due To Vertical Alignment

Figure 2

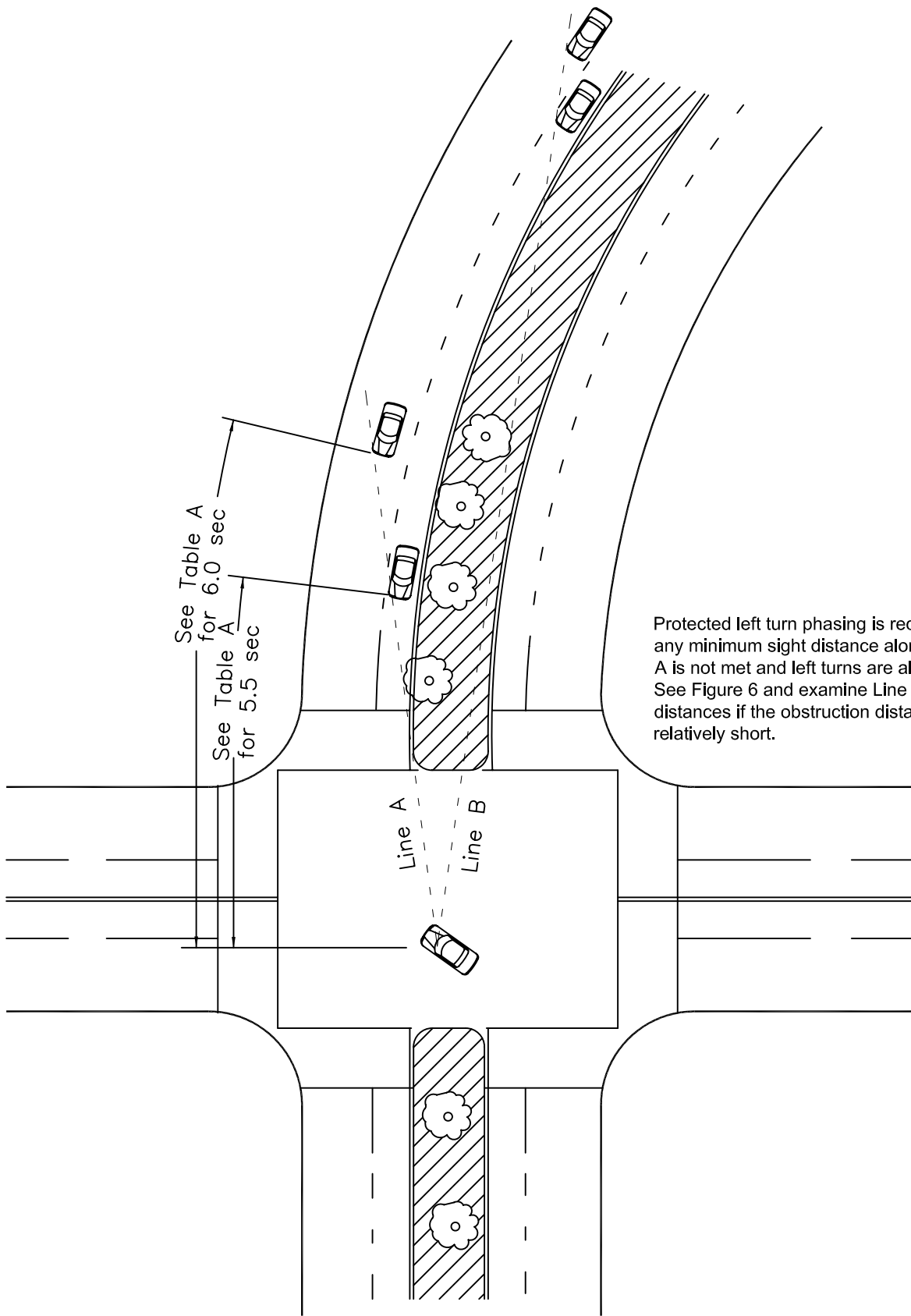

Example of Restricted Sight Distance Due To Physical Obstruction

Figure 3

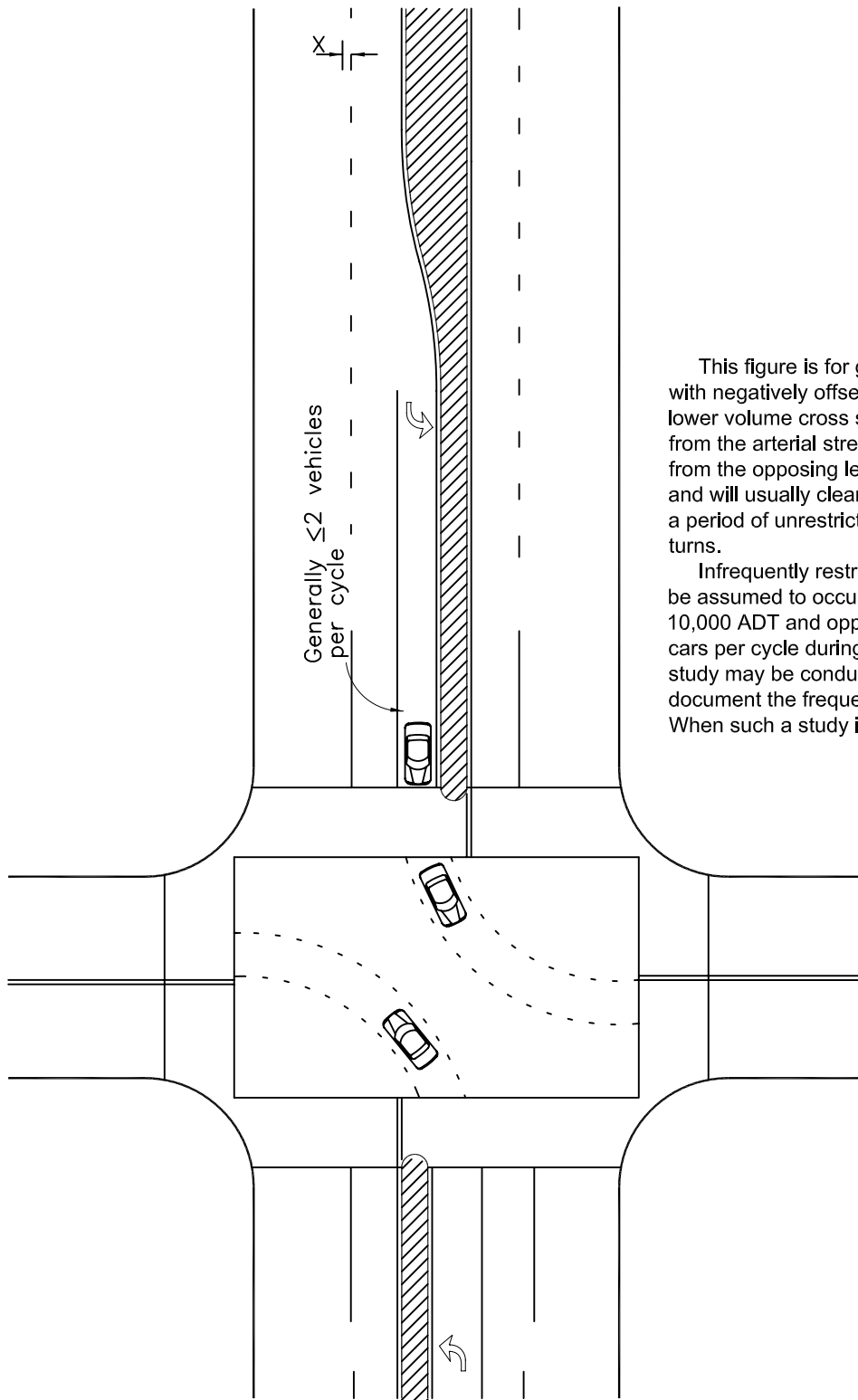

This figure is for general use on arterial highways with negatively offset left turn lanes at intersections with lower volume cross streets and /or low volume left turns from the arterial streets. In these situations the queuing from the opposing left turns will be short or infrequent and will usually clear during the cycle, thus resulting in a period of unrestricted sight distance for permissive left turns.

Infrequently restricted sight distance generally would be assumed to occur if the cross street has less than 10,000 ADT and opposing left turns are less than two cars per cycle during the peak hour. However, a left turn study may be conducted in place of these guidelines to document the frequency of restricted sight distance. When such a study is conducted, refer to Figure 5.

Example of Infrequently Restricted Sight Distance Due to Negatively Offset Left Turn Lanes with Light Opposing Left Turn Demand

Figure 4

CITY OF LOS ANGELES DEPARTMENT OF TRANSPORTATION	Title Restricted Sight Distance Criteria for Protected Left-Turn Phasing	Drawing No. S-497.0	5 7
---	---	-------------------------------	--------

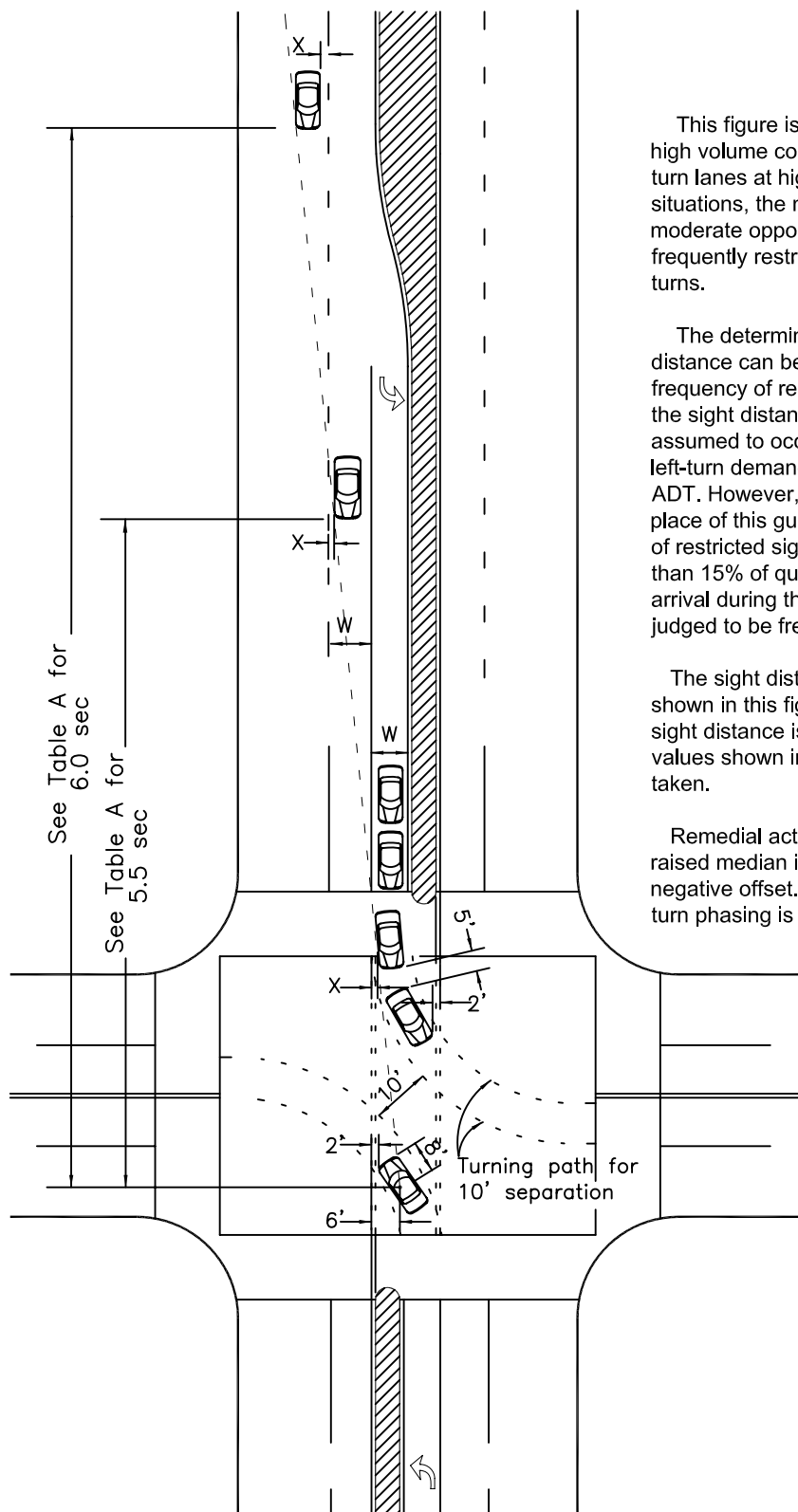

This figure is for general use on arterial highways or high volume collector streets with negatively offset left turn lanes at higher volume cross streets. In these situations, the negative offset, in combination with moderate opposing left turn demand, may result in frequently restricted sight distance for permissive left turns.

The determination of frequently restricted sight distance can be determined by : 1) Assessing the frequency of restricted sight distance; and 2) measuring the sight distance. Restricted sight distance will be assumed to occur frequently with moderate opposing left-turn demand if the cross street has more than 10,000 ADT. However, a left turn study may be conducted in place of this guideline to document the actual frequency of restricted sight distance. If the study shows that more than 15% of queues do not clear during their cycles of arrival during the peak hour then restricted visibility is judged to be frequent.

The sight distance can be plotted on a striping plan as shown in this figure or as measured in the field. If the sight distance is frequently restricted and is less than the values shown in Table A then remedial action should be taken.

Remedial action should first consider removal of the raised median island and restriping to eliminate the negative offset. If this is not feasible then protected left turn phasing is required.

Generally, an Arterial or High Volume Collector Street (10,000 ADT)

W,ft	X,ft
9	1.5
10	2.0
11	2.5
12	3.0

Example of Frequently Restricted Sight Distance Due To Negatively Offset Left Turn Lanes with Moderate Opposing Left Turn Demand

Figure 5

Left turning motorists can see downstream of Line A (which is defined by the first vehicle in a queue) and upstream of Line B which is defined by the last vehicle in an 85th percentile queue. They cannot, however, see between Lines A and B. If opposing vehicles can be seen at the required sight distances, shown in Table A, either downstream of Line A or upstream of Line B, then protected left turn phasing is not required. If however, the required sight distances lie between Lines A and B then visibility is inadequate for left turning decisions and protected left turn phasing is required. In the absence of documented observations, the 85th percentile queue length, in feet, is assumed to be $40 V/N$, where V equals the peak hour left turn volume and N equals the number of signal cycles per hour.

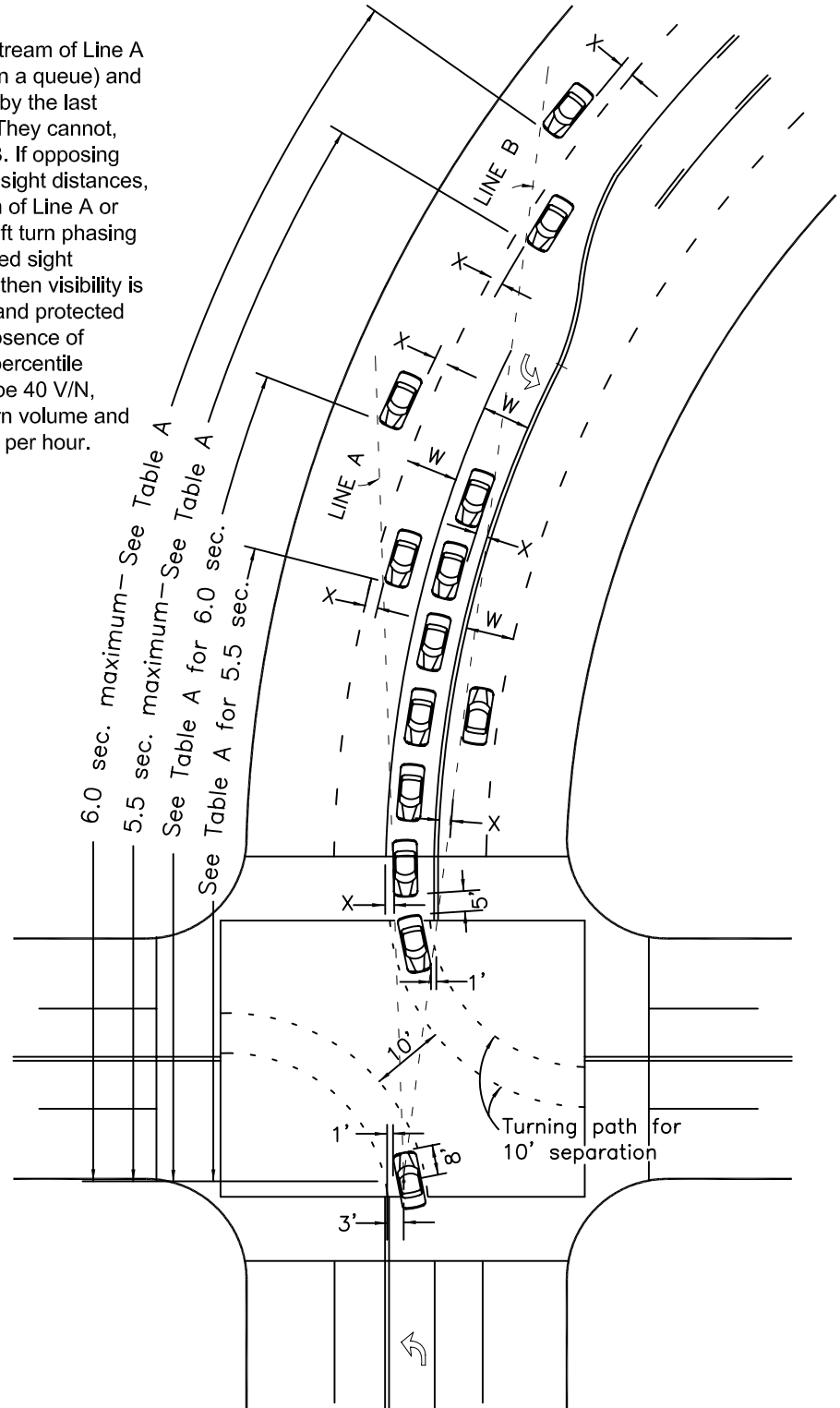

W,ft	X,ft
9	1.5
10	2.0
11	2.5
12	3.0

Example of Frequently Restricted Sight Distance Due To Moderate Opposing Left Turn Demand in Combination with Right Horizontal Curvature

Figure 6