

CITY OF LOS ANGELES
DEPARTMENT OF TRANSPORTATION

**SPECIAL PROVISIONS AND
STANDARD DRAWINGS FOR
THE INSTALLATION AND MODIFICATION OF
TRAFFIC SIGNALS**

“RED BOOK”

July 2008

Rita L. Robinson, General Manager

DATE	COMMENTS
July 2009	Revised Section A7 “Contractor Requirements”
	Revised page 1 of “No Left & No Right Turn Electric Sign” (S-58.13)
August 2009	Increased F-1/F-8 foundation depth to 36” (S-52.1)
December 2011	Added drawings S-76.9 and S-79.9B;
	Revised drawings S-50.1, S-52.1.3, S-52.1.6, S-63.1, S-72.0A, S-76.3 S-76.6, S-76.7, S-76.8, S-78.5.1, S-79.8 and S-79.9.
	Revised Sections A6, A10, A11, B2, B7 and B12 of Special Provisions
April 2012	Revised Section drawing S-52.1.6
May 2012	Added drawing S-99.0
July 2012	Revised Sections A5 and B4d1 of Special Provisions
August 2012	Revised drawing S-52.1.6
August 2014	Revised drawing S-70.4A
April 2016	Revised drawings S-51.1.2A, S-51.1.3A, S-51.8, S-51.9A, S-52.1, S-52.1.6, S-57.2B, S-57.3 and S-70.1D Deleted drawings S-52.7.2, S-52.7.4
September 2016	Revised drawings S-51.1.3A, S-73.0 and S-73.1
May 2017	Revised drawing S-70.1D
September 2020	Added drawing S-52.1.7
July 2022	Added drawings S-78.5.3 and S-78.5.4 Revised drawing S-77.8A
February 2023	Revised drawing S-78.5.3 Deleted drawing S-78.5.4

TABLE OF CONTENTS

	<u>PAGE</u>
INTRODUCTION	1

PART I SPECIAL PROVISIONS

A. GENERAL

1. Definitions	2
2. LADOT District Field Operations Yards	2
3. Purchase of This Document.....	2
4. Material.....	2
5. Notification.....	3
6. Worksite Traffic Control	3
7. Contractor Requirements	4
8. Traffic Control Signing	4
9. LADOT Supplied Material.....	4
10. Controller Testing.....	5
11. Salvage Equipment.....	5

B. CONSTRUCTION PRACTICES

1. Pull Boxes.....	6
2. Conduit	
a. Material.....	6-7
b. Trenching.....	7
c. Installation in Roadways	7-8
d. Backfill	8
e. Installation in Parkways	8
f. Size	8
3. Backfilling	9-11
a. Schedule	9
b. Foundation Holes	9
c. Trenches	9
Table I (Backfilling, Restoration of Excavations and Removal of Equipment and Material).....	10
4. Conductors and Cable	
a. Material.....	11
b. Identification.....	12
c. Interconnect	
1) Direct Wire	12
2) Multi-Pair Interconnect Cable	12
3) Telephone and Fire Alarm.....	12
d. Inductive Loop Detectors	12-13

1)	Wire Splicing.....	12
2)	Loop Detector Wire Routing System	13
3)	Sealant	13
4)	Transit Bus or Photo Red-Light Detector Wire.....	13
e.	Conductor Splicing and Termination	13-14
1)	Connectors.....	13
2)	Multi-Conductor Signal Cables in the Controller Pull Box	13
f.	Inductive Loop Detector Lead-in Cable	14
g.	Transit Bus or Photo Red-Light Detector Lead-in Cable.....	14
h.	Conductors Attached to Controller Field Terminals	14
i.	Field Testing.....	14
1)	Continuity	14
2)	Ground.....	14
3)	Insulation Resistance.....	14
5.	Fiber Optic Cable	
a.	General	
1)	Description	15
2)	Performance.....	15
3)	Construction	15
4)	Jacket.....	15
5)	End Termination Cable.....	15
6)	Identification.....	15
7)	Reels	15
8)	Installation	15
b.	Splicing of Fiber Optic Cable.....	16
6.	Controller.....	16
7.	Ground Rods.....	16
8.	Service.....	17
9.	Signal Heads	
a.	Vehicle and Pedestrian Signal Head Covers	17
b.	Vehicle Heads.....	17
c.	Pedestrian Heads	17
d.	Traffic Signal Visors	17
e.	Light Emitting Diodes (LED) Signal Modules	17
10.	Detectors.....	18
11.	Lines and Grades	18
12.	Anchor Bolt Height	18

C. TABLES

28-Conductor Cable Color Code Identification	19
--	----

PART II
STANDARD DRAWINGS

<u>TITLE</u>	<u>DRAWING NUMBER</u>	<u>PAGE</u>
Traffic Signal Symbols	S-50.1	20-23
<u>Standards</u>		
Type 1, Typical Mounting	S-51.1.2A	24
Types 1, 1A, 8 & 9.....	S-51.1.3A	25
Type 7	S-51.7	26
Type 8 (337 Post-Top Mounted Cabinet).....	S-51.8.....	27
Type 9	S-51.9A.....	28
Type 16	S-51.9.5.....	29
CD 954.....	S-51.9.6.....	30
100 MPH Poles	S-52.1.6.....	31-32
Camera Poles	S-52.1.4B	33-34
BSL Poles with RRFB Sign Arm.....	S-52.1.7.....	35-38
<u>Temporary Standards</u>		
For Type 1 Standard.....	S-57.2B	39
For Type CD 954 Standard (Without Luminaire Arm).....	S-57.2C	40
For Type CD 954 Standard (With Luminaire Arm).....	S-57.2D	41
Controller Cabinet (337), for Type 8 Standard.....	S-57.3	42
<u>Fittings</u>		
Typical Post-Top Mounting.....	S-61.1	43
Typical Clamp Mounting.....	S-62.1	44
Typical Terminal Compartment & Pole Plate Mounting.....	S-63.1	45
Special Mast Arm Mountings	S-63.1.4.....	46-47
Mast Arm Mounting	S-67.1	48
Removable Lifting Plate for Controller Cabinets	S-68.1	49
<u>Visors</u>		
8" Diameter Beveled.....	S-76.3	50
12" Diameter Beveled.....	S-76.6.....	51
Long Visor, 8" & 12" Diameter Full Circle	S-76.7	52
Pigeon Visor, Tunnel	S-76.8.....	53
8" & 12" Diameter Full Circle.....	S-76.9	54
<u>Push Buttons</u>		
Pushbutton, Installation.....	S-72.0A	55
Pushbutton.....	S-72.1.1	56
Bicycle Pushbutton Sign.....	S-72.2	57
Pedestrian Pushbutton Sign Non-Actuated.....	S-73.0.....	58
Pedestrian Pushbutton Sign Actuated.....	S-73.1	59

Loops

Inductive Loop Installation	S-70.1A	60-61
Bicycle Detector.....	S-70.1D	62
Preformed Loop Installation	S-70.1E.....	63
Transit Priority Loop.....	S-70.1F.....	64
System Detector Loop Lead-in Cable (2, 3, 4 pair).....	S-70.2	65
Multi-Pair Loop Lead-in Cable.....	S-70.3	66
Light Rail Train (LRT) Track Area Detector Loop.....	S-70.4A	67-69

Cabinets

337 Cabinet, Post-Top Mounted.....	S-75.9A	70
Cabinet, Controller, Type M.....	S-75.5.3	71
Type II Communication Cabinet & Foundation	S-75.0C	72

Pull Boxes

Pull Box, Types PB-2 & PB-3	S-78.5.1	73
Metal Cover Traffic Pull Box	S-78.5.2	74
Composite Pull Box, Types PB-2 & PB-3.....	S-78.5.3	75
Special Cover for Pull Box	S-78.8.....	76
Fiber Optic Splice Box I.....	S-79.02A	77
Fiber Optic Splice Box II.....	S-79.02B	78

Foundations

Foundation, Types F-1 & F-8	S-52.1	79
Foundation, Type F-2.....	S-52.2	80
Foundation, CIDH Type F-2.....	S-52.2.2	81
Foundation, Type F-7.....	S-52.7	82
Adapter Base Plate (For F-1 to F-7 Foundation)	S 52.7.1.....	83
Foundation, Type F-12A.....	S-52.1.2B	84
Foundation, Type F-332.....	S-52.1.3	85

Service

Overhead Service, DWP	S-79.8	86
Underground Service, DWP	S-79.9	87
Type II Service Distribution Cabinet.....	S-79.9A	88
Service Grounding Conduit System	S-79.9B	89
Service, Telephone, ATSAC 332 Cabinet	S-79.3A	90

Overhead Signs

Sign Cantilever, 12 foot Arm.....	S-98.0	91
Sign Cantilever, 22 foot Arm.....	S-92.3	92
Sign Cantilever, 34 foot Arm.....	S-92.2	93-94
Laminated Overhead Sign Mounting System	S-45.0	95
14' Cantilever Changeable Message Sign	S-92.4	96-97
Trailblazer Sign.....	S-58.16.....	98-99
Overhead Sign Structure	S-99.0.....	100-104

Miscellaneous

Backplates	S-77.8A.....	105
Mast Arm Mounted Street Name Sign	S-486.0.....	106-107
Mast Arm Street Name Sign Bracket Type 1	S-457.0.....	108
No Left and No Right Turn Electric Sign.....	S-58.13.....	109-110
Use Tunnel, Electric Sign	S-58.14.....	111
R3-5 Electric Sign.....	S-58.17.....	112
Lane Usage Control Electric Sign.....	S-58.18.....	113
R3-9a Electric Sign.....	S-58.19.....	114
Sign Enclosure	S-58.21.....	115
Electric Train & Bus Warning Sign.....	S-58.23.....	116
Transit Priority Unit Cabinet Detail.....	S-70.3A.....	117-122
Pedestrian Barricade	S-454.2.....	123

INTRODUCTION

This document, Special Provisions and Standard Drawings for the Installation and Modification of Traffic Signals, governs the contractual construction activities related to traffic signals in the City of Los Angeles. Where no contract is applicable, but reference is made to “contractor”, said provisions apply to the City of Los Angeles Department of Transportation field forces. This edition supersedes all previous editions. This document supplements the Standard Specifications for Public Works Construction, or “Green book”, as adopted by the City of Los Angeles Board of Public Works and as modified by the corresponding issue of the “Brown Book.” Together, all of these documents govern all contractual construction activities.

All materials used in the installation and/or modification of traffic signal systems shall conform to the latest Material Specification of the City of Los Angeles Department of Transportation. The LADOT Material Specifications may be obtained from the Material Services Division, Department of Transportation, 100 South Main Street, 10th Floor, Los Angeles, California, 90012, telephone number (213) 928-9636 or can be downloaded in PDF format from the LADOT web site at: http://www.ladot.lacity.org/tf_Development_Review.htm.

PART I
SPECIAL PROVISIONS

A. GENERAL

1. DEFINITIONS

ATSAC: Automated Traffic Surveillance and Control.
LABPW: City of Los Angeles Board of Public Works.
LADOT: City of Los Angeles Department of Transportation
MUTCD: Manual of Uniform Traffic Control Devices (California Supplement)
WATCH: Work Area Traffic Control Handbook

2. LADOT DISTRICT FIELD OPERATIONS YARD

The address and telephone numbers of the LADOT Field Operations Yards are listed below:

- Valley Yard: 14832 Raymer Street, Van Nuys; (818) 756-7845
- Central Yard: 1831 Pasadena Ave, Los Angeles; (213) 485-7689
- Western Yard: 2801 Exposition Blvd, Los Angeles; (213) 485-6818

3. PURCHASE OF THIS DOCUMENT

This document, Special Provisions and Standard Drawings for the Installation and Modification of Traffic Signals, may be purchased from the LADOT Records Section, 100 South Main Street, 10th Floor, Los Angeles, California, 90012, telephone number (213) 972-5060. This document can also be downloaded in PDF format from the LADOT web site at: http://www.ladot.lacity.org/tf_Development_Review.htm

4. MATERIAL

All materials used in the installation and/or modification of non-temporary signal systems shall be new and unused, unless otherwise specified on the plan and shall conform to the latest LADOT Material Specifications. Temporary signal standards and signal heads installed on these standards may be used, but shall be undamaged.

5. NOTIFICATION

The contractor shall notify LADOT Traffic Signal Inspector at Central Yard, (213) 485-1071, Valley Yard, (818) 756-7852, or Western Yard, (213) 485-6834, depending on the project location, five (5) working days prior to start of construction on any project involving work on traffic signals or signal systems. In case of emergency, the LADOT Traffic Signal Inspector may authorize requests for change orders. The signal inspector shall be notified for inspection approval of all underground substructures, including foundations, 48 hours prior to covering the work or pouring foundations.

Any work that will affect a major ATSAC communication facility (i.e. fiber optic cable, main communication trunk cable, communication hub site, etc.) as determined by the LADOT Traffic Signal Inspector, shall be prohibited between the hours of 6:00 A.M. to 9:00 A.M. and 3:00 P.M. to 7:00 P.M. on weekdays, except national holidays. If such work requires that ATSAC communication system be off line for five (5) or more working days during the hours permitted, the contractor shall provide temporary facilities in order to maintain operation of the ATSAC system. These temporary facilities may include, but are not limited to, overhead spans of fiber optic or communication cable, and any related equipment. Any work required to install and remove these temporary facilities shall be done at the contractor's expense. Once said temporary facilities are in place, the contractor shall have thirty (30) working days in which to complete construction and to fully restore the ATSAC communication system.

Failure to notify the LADOT Traffic Signal Inspector prior to start of work will result in suspension of work. Delays in the complete restoration of the signal system may require the contractor to pay liquidated damages as specified in the contract or may require LADOT forces to complete the work which will be charged to the contractor and/or permittee.

Traffic control shall be in accordance with the LADOT Standard Plan S-488.0, the latest edition of the WATCH manual, MUTCD (California Supplement), associated worksite traffic control plans or any additional requirements called for on the plan or in the special provisions.

6. WORKSITE TRAFFIC CONTROL

The contractor shall install and maintain overhead cable or wires to maintain existing signal operation when installing new conduit runs across the street, replacing cable runs across the street, or installing or replacing signal standards, foundations or heads.

Regular traffic signal control (including interconnect) shall be maintained from 6:00 A.M. to 9:00 A.M. and 3:00 P.M. to 7:00 P.M. on weekdays, except national holidays. National holidays are New Year's Day, President's Day, Memorial Day, Independence Day, Labor Day, Veteran's Day, Thanksgiving, and Christmas. Flashing, activation and deactivation of signals and interconnect may occur only between 9:00 A.M. and 3:00 P.M. and between 7:00 P.M. and 6:00 A.M. on weekdays, except national holidays, and shall be accomplished only by an LADOT traffic signal electrician. The LADOT traffic signal electrician may reschedule or cancel a scheduled signal deactivation in the event of unsafe working or weather conditions.

Arrangements to deactivate signals (signal shutdown) shall be made at least 24 hours in advance, Monday-Thursday at (213) 473-8478 before 9:00 A.M. on non-holiday weekdays. The LADOT project number as shown on the traffic signal plan must be given at this time. The contractor may be charged for electrical and traffic control work provided by LADOT.

7. CONTRACTOR REQUIREMENTS

All traffic signal and/or related electrical work shall be performed and inspected under the conditions of the most current, amended Board of Public Works “Enhanced Electrical Safety Policy”. The “Enhanced Electrical Safety Policy” is applicable for all work on traffic signals and/or related electrical work performed for LADOT regardless of contract cost.

The Contractor shall certify that all personnel employed in traffic signal and/or related work fully comply with the requirements of the “Enhanced Electrical Safety Policy”.

Failure to fully comply with the requirements of the “Enhanced Electrical Safety Policy” may result in a suspension of work and/or sanctions against the Contractor.

THE CONTRACTOR SHALL NOT WORK ON TRAFFIC SIGNAL CIRCUITS WHILE THEY ARE ENERGIZED

When a signal shutdown is approved by LADOT, it shall be two (2) hours maximum, unless approved for a longer period, and may occur only between the hours of 9A.M. to 3P.M. Monday-Thursday on non-holiday weekdays. The Traffic Signal Inspector may authorize work necessitating longer periods of time. Preliminary work associated with the signal shutdown shall be done prior to the actual shutdown in order to minimize the amount of time necessary for the completion of the work. Sufficient staffing and equipment shall be employed by the contractor to minimize the shutdown period. Once a shutdown is affected, all work shall be diligently pursued without interruption until the signals are back in normal operation.

8. TRAFFIC CONTROL SIGNING

Any traffic control signing damaged or lost by the contractor shall be replaced at the contractor's expense. Arrangements for obtaining replacement signing (with subsequent billing) shall be made with the LADOT Bureau of Accounting, General Accounting Division, at (213) 972-5908. Prior to the completion of construction, the contractor shall permanently mount all traffic control signing per LADOT standards.

Five (5) working days prior to any traffic signal pole removal, the appropriate yard Superintendent shall be notified for the removal and reinstallation of pole and mast arm mounted street name signs. The address and phone numbers of the LADOT Field Operations Yards are shown in Section 2.

9. LADOT SUPPLIED MATERIAL

Arrangements for obtaining materials, except traffic signal controller assemblies, to be supplied by LADOT as indicated on traffic signal design plans, shall be made ten (10) working days in advance by contacting the LADOT Field Operations Division at (213) 928-9620.

10. CONTROLLER TESTING

All traffic signal controller assemblies being furnished and installed by the contractor must be tested by LADOT. The completely assembled controller with cabinet and auxiliary equipment shall be delivered to the LADOT Traffic Signal Shop at Piper Technical Center, 555 Ramirez Street, Los Angeles, California, 90012, telephone number (213) 473-8468, at least thirty (30) working days prior to desired pick-up date. The traffic signal program for the Model 2070 controller will be supplied and installed by LADOT. Upon successful completion of the testing, the contractor shall pick up the traffic signal controller assemblies within fifteen (15) working days after notification for installation at the job site.

11. SALVAGE EQUIPMENT

All arrangements for traffic signal equipment specified to be returned to LADOT shall be made five (5) working days prior to the desired delivery date.

Controller cabinets shall become the property of the contractor, unless indicated otherwise on the project plans or by the LADOT Traffic Signal Inspector. The model 170 or 2070 controller units, model 210 or 2010 conflict monitor and specialized equipment, as determined by the LADOT Traffic Signal Inspector, contained within the cabinet remain the property of LADOT and will be removed from the controller cabinet by the LADOT Traffic Signal Inspector.

Return controller cabinets to the following location:

LADOT Equipment Repair Shop
447 Ducommun St, Los Angeles, California, 90012
Telephone: (213) 847-2944

The contractor shall exercise due care in the removal of traffic signal equipment, including signs and sign posts, that have been specified to be reused or salvaged, so that the equipment will remain in the same condition as that prior to removal. The contractor will be required to replace any traffic signal equipment that was damaged or destroyed while in the contractor's care. The contractor shall be responsible for cleaning traffic signal equipment prior to delivery.

B. CONSTRUCTION PRACTICES

1. PULL BOXES

The tops of pull boxes installed in the sidewalk areas shall be flush with the surrounding grade or the top of the adjacent curb. Where practical, pull boxes adjacent to standards shall be placed with a clearance of three (3) feet from the side of foundations. Pull boxes shall not be placed in curb ramp areas or driveways. Pull boxes shall be located beyond the door opening paths of traffic signal controllers. Unless physically impractical, pull boxes shall be installed at least six (6) inches from any substructure or back of curb. This is to allow for rock under and cement around the pull box.

Type PB-3 pull boxes shall be used for all:

- a. Interconnect runs (telephone and/or fiber optic cables)
- b. Power service conduits
- c. Controllers
- d. Junctions with four or more conduits
- e. Junctions with three conduits, two of which are three-inch in diameter
- f. All street crossings

Type PB-2 pull boxes shall be installed at all other locations, unless otherwise noted on the plans.

The service pull box shall be separated from the intersection wiring whenever possible.

For fiber optic runs, the spacing between the pull boxes shall be at intervals not to exceed 600 feet. For all other runs, pull boxes shall be spaced at intervals not to exceed 300 feet.

Existing pull boxes are considered to be an integral part of the surrounding concrete sidewalk. Where the surrounding sidewalk surface is composed of a special material, pull boxes with covers of compatible material shall be used to obtain a homogeneous appearance of the sidewalk area. The contractor shall be required to replace the pull boxes when modifying or replacing the surrounding concrete. Replacement of pull boxes shall be made per LADOT Standard Drawing S-78.5.3 or S-78.8. Under no circumstances is any pull box to be reused or modified for reuse.

2. CONDUIT

a. Material

Rigid non-metallic conduits conforming to the requirements in UL Publication 651 for Rigid Non-metallic Conduit (PVC Schedule 80) shall be used, except where galvanized rigid steel conduit is required or permitted.

Galvanized rigid steel conduit shall be used where specified in this manual, where shown on the plans, or where jacking is required.

Galvanized rigid steel conduit is permitted where exposed above ground as a permanent installation or where authorized by the LADOT Traffic Signal Inspector. A separate #8 green ground wire and a Kevlar High Strength Conduit Measuring Tape, Greenlee catalog number 39243, 39244, 39245 (or equivalent), shall be

included within the PVC conduits at the time of installation. For the galvanized steel conduit a Kevlar High Strength Conduit Measuring Tape, Greenlee catalog number 39243, 39244, 39245 (or equivalent), shall be included. All the #8 green ground wires shall be spliced together and connected to the “equipment ground bus” bar inside the controller cabinet.

b. Trenching

PVC conduit shall be installed in open soil trenches and in pavement trenches whose edges have been saw cut, except in the vicinity of pull boxes where it may be bored in pre-drilled, augured or air-blown holes. Generally, trenches should be four inches wide. Where trenching occurs within Portland Cement Concrete, a 24-inch wide section of roadbed whose edges have been saw cut shall be removed.

Trenching is not permitted through Portland Cement Concrete structures, such as bus pads, spandrels and cross gutters. Where these are encountered, jacking with galvanized rigid steel conduit, or boring with PVC conduit is required.

Traffic signal conduits shall be separated from street lighting conduits. New conduit runs shall be of the same size and material throughout the run. Empty PVC conduit (conduit only) shall include a #8 green ground wire and a Kevlar High Strength Conduit Measuring Tape, Greenlee catalog number 39243, 39244, 39245 (or equivalent). Empty galvanized rigid steel conduit (conduit only) shall include Kevlar High Strength Conduit Measuring Tape, Greenlee catalog number 39243, 39244, 39245 (or equivalent). Existing underground conduit being incorporated into a new system shall be cleaned with a mandrel or cylindrical wire brush and blown out with compressed air.

c. Installation in Roadways

Interconnect, fiber optic, system and bus detector loop conduits shall be installed at a consistent depth throughout a block with minimum cover of 18 inches (below the established edge of the gutters) on Major and Secondary highways, and 15 inches on all other streets or alleys, unless otherwise specified on the Plans.

Conduits containing traffic signal load wires (115 volts) shall be installed at a consistent depth, with the minimum and maximum depths as per Section 307-2.5 of the Standard Specifications for Public Works Construction. All street crossings shall be installed at 30-inch depth.

Conduit trenches approximately four (4) inches wide may be excavated at locations shown on the Plans using earth saw methods. The preferred alignment is along the outer edge of an existing gutter.

Where there is no gutter, the trench shall be at a distance of 36 inches from the existing or future curb face (which will accommodate the construction of a 24-inch wide gutter in the future), or as shown on the Plans. Removal and replacement of all pavement between the trench and the edge of the existing pavement shall be done at the discretion of the Engineer.

On Major or Secondary highways, the asphalt concrete pavement resurfacing shall conform to the Standard Specifications for Public Works Construction.

On all other asphalt concrete streets or alleys, the upper three inches of trench shall be completed with material matching the existing pavement. Major and Secondary Highways are shown on the Streets and Highways Designation map.

Portland Cement Concrete (PCC) roadway resurfacing shall be a minimum of six (6) inches thick and twenty-four (24) inches wide for all classifications of roadway.

Concrete pavement serving as bus pads, spandrels, cross gutters or local depressions shall not be cut. In addition, concrete curbs and gutters (regardless of gutter width) shall not be cut. At these locations, the conduit shall be bored or jacked.

It is desirable to maintain a straight alignment. Routing of a conduit at a bus pad or at any other protrusions beyond the gutter edge must be approved by the Engineer. It should be noted that some installations might require locations in back of the curb. Locations where conduits are within one foot vertically and two feet horizontally from, or otherwise in conflict with, existing utilities will not be permitted.

d. Backfill

Backfill may be Portland Cement Concrete (PCC) when required by the Engineer, or a one-sack sand-Portland Cement slurry mix. Portland Cement Concrete backfill shall be a 520-C-2500 mix with a 4-inch maximum slump. For PCC, calcium chloride must be added up to the maximum amount allowed by Section 201-1.2.4 of the Standard Specifications.

e. Installation in Parkways

All conduit installations in parkways shall have a minimum cover of 16 inches below surface (LAMC Sec. 62.04). If directional bore is permitted by the Engineer, conduit depth shall have a minimum cover of 22 inches below surface.

All existing improvements in parkways, including landscaping and sprinklers, shall be protected from damage or restored to pre-construction condition.

f. Size

All cross street conduit runs and all interconnect conduit runs between intersections, except for fiber optic interconnect runs, shall be three-inch in diameter. All fiber optic interconnect runs shall be two-inch in diameter. Three-inch conduit shall be used between an F-8 foundation and the adjacent PB-3 pull box. Two three-inch conduits are required between an F-332 foundation and the adjacent PB-3 pull box. One-inch conduit shall be used between an F-7 foundation and the adjacent pull box. All other new conduit runs shall be two-inch in diameter, unless otherwise specified on the plan.

When existing conduit runs are to be modified or extended, the material and size of the new conduit shall be the same as the existing conduit.

3. **BACKFILLING**

a. Schedule

All excavations for the installation of foundations, conduits and pull boxes, and removal of old systems, shall be backfilled, compacted and restored to match adjacent areas and excess material removed from the job site within the calendar days prescribed in the following Table I. The number of days allowed commences with the start of excavation unless otherwise permitted by the Engineer. All trenching activity, commenced each day, shall be fully backfilled to the finished surface grade at the end of the day; final resurfacing shall be completed within five (5) working days. All streets and all trenches shall be maintained in safe condition until final resurfacing.

b. Foundation Holes

A one-sack slurry mix shall be used to backfill foundation holes created as a result of removing the existing foundations. If the area excavated for a new foundation is deemed to have unstable soil as determined by the Engineer, then the area excavated shall be backfilled with one sack slurry mix, 24 hrs prior to re-excavation for the new foundation. Where the new foundation is within three (3) feet of the existing foundation, the removal and backfill of the existing foundation shall occur prior to the installation of the new foundation.

c. Trenches - See Section B.2, Conduit

TABLE I

**BACKFILLING, RESTORATION OF EXCAVATIONS AND REMOVAL OF
EQUIPMENT AND MATERIAL**

	Backfilled & Compacted or covered	Excess Equipment &/or Material removed from job site	Permanent Resurfacing
1. Parkway: Pilot Holes and Jacking Pits (1) (2)	Daily	3 days	7 days
2. Roadway Excavations (1)(2)(3)	Daily	Daily	N/A
3. Existing Foundation and Pull Box Removals	Daily	Daily	7 days
4. Existing Standard (poles) and misc. equipment	N/A	Daily	N/A
5. New Foundation Installations	Daily	Daily	7 days
6. New Pull Boxes:Excavation and Placement	3 days	5 days	7 days

(1) Excavation for jacking pits and excavations within roadways shall be backfilled and compacted in accordance with Subsection 301-1.3 of the Standard Specifications for Public Works Construction.

(2) Approved protective plates/covers shall be placed immediately at the end of each day until excavations are no longer needed.

(3) Temporary asphalt concrete (cold mix) shall be placed immediately after the backfill is compacted in accordance with subsection 306-1.5.1 of the Standard Specifications for Public Works Construction.

The previous requirements do not relieve the Contractor of his/her obligation to properly place warning signs and barricades as well as maintain the job site in accordance with Subsections 7-9 and 7-10 of the Standard Specifications for Public Works Construction and the Work Area Traffic Control Handbook (WATCH) manual.

If the times specified in Table I are exceeded, the Contractor (as directed by the Engineer) shall stop all other work until the restoration work is brought into compliance. Contact time will continue to be charged during such periods.

Where field conditions are such that these Special Provision are conflicting, the Engineer shall be notified immediately.

Where excavations occur in the sidewalks or other pedestrian ways, the Contractor shall provide a safe and orderly pedestrian passage around the excavation area. The pedestrian passage shall not subject pedestrians to hazards from traffic or construction operations, or cause pedestrians to walk upon unsuitable or hazardous surfaces.

4. CONDUCTORS AND CABLE

a. Material

All permanent conductors shall be run inside conduits or standards. Multi-conductor cable shall be used for all circuits in lieu of individual conductors. The multi-conductor cable shall conform to the latest revision of the following LADOT Specifications:

- 92-089-01 (28 conductor cable)
- 92-091-01 (13 conductor cable)
- 92-090-01 (9 conductor cable)
- 92-094-01 (5 conductor cable)

Conductors shall be solid copper wire of the gauge shown on the plans, unless otherwise specified.

Whenever new conductors are to be installed in a conduit with existing individual conductors (service wires excepted), all individual conductors shall be removed and replaced with multi-conductor cable. 28-conductor cable shall be installed in all new street crossings unless otherwise specified on the plans.

Only Kevlar High Strength Conduit Measuring Tape, Greenlee catalog number 39243, 39244, 39245 (or equivalent) shall be used for "pulling in" or installing cables in ANY TYPE CONDUIT. At no time shall any type "rope" be used to install cables or wires.

All temporary overhead circuit runs shall be multi-conductor cable. Where exposed over the roadway, they shall be at least 20 feet above ground. Over the sidewalk and roadside areas not open to vehicular traffic, they shall be at least 12 feet above ground.

Service conductors shall have black and white insulation.

b. Identification

Each communication cable shall be identified in all communication cabinets and splice vaults by a plastic tag 1-inch by 4-inch in size, with the cable run identification characters in ½-inch letters and secured to the cable with two nylon tie-wrap devices.

Each cable shall be identified in all controller cabinets by a plastic tag ½-inch by 2-inch in size, stamped with the cable run identification characters in ¼-inch letters and secured to the cable with two nylon tie-wrap devices.

Each conductor shall have clear, distinctive and permanent bands for identification. These identification bands shall be used even though the conductors have clear markings within their insulation. Bands shall conform to the latest edition of Standard Specifications for Public Works Construction. These permanent identification bands shall be marked as specified. All conductors shall be labeled within each affected pull box.

c. Interconnect

- 1) **Direct Wire:** Interconnect cable with 7 - #14 wires per LADOT Specification 92-039-03 (latest revision) shall be continuous from controller to controller, unless splices are specifically authorized by the LADOT Traffic Signal Inspector. Where splices are authorized by the LADOT Traffic Signal Inspector, they shall be soldered and shall be secured using vinyl, water-tight, spring tensioned, silicone filled, direct burial wire connectors, as described in LADOT Specification 56-002-03 (latest revision).
- 2) **Multi-Pair Interconnect Cable:** Filled telephone type cable shall consist of paired #22 AWG solid annealed copper conductors. The cable shall be polyethylene insulated and aluminum shielded, conforming to the construction requirements and environmental, mechanical, and electrical tests of LADOT Specification 92-069-01 (latest revision) for filled telephone cable. The cable sizes shall be 6, 12, 25, 50, and 75 pair. Cable splices shall only be made at a communication cabinet, splice vault or controller. Punch down the “IN” cable on the left side of the T-66 block and the “OUT” cable(s) on the right side of the T-66 block.
- 3) **Telephone and Fire Alarm:** Interconnect cable using telephone lines or former fire alarm lines shall be #14 AWG stranded twisted pair copper wire having 600-volt insulation and overall shield and jacket.

d. Inductive Loops Detector

Inductive loop detectors shall be installed as per LADOT Standard Drawing S-70.1A or as otherwise approved by LADOT. To the greatest extent practical, loops should be installed in one continuous medium. Loop wire shall conform to LADOT Specification 92-093-01 (latest revision). All detector lead-in cable connections and terminations shall be soldered.

- 1) **Wire Splicing:** Where circuits are to be spliced, each splice shall be twisted

and soldered with rosin core (no acid core or acid paste shall be used) then sealed with vinyl, watertight, spring tensioned, silicone filled, direct burial wire connector per LADOT Specification 56-002-03 (latest revision).

- 2) **Loop Detector Wire Routing System:** Unless otherwise specified, all detector loops shall be wound in a clockwise direction. The input (or start) wire shall be tagged with an odd number, the output (or finish) wire with the next higher number. A plastic tag ½-inch by 2-inch shall be tie wrapped around each loop pair to identify each pair by phase and numbers of individual conductors.
- 3) **Sealant:** The loop wires shall be covered and sealed using Caltrans approved “Hot-Melt Rubberized Asphalt Sealant” for loop installation. Note: “Hot-Melt Crack Sealant” shall not be used in place of the above.
- 4) **Transit Bus or Photo Red-Light Detector Wire:** All Transit Bus or Photo Red-Light loop wire shall conform to IMSA Specification 51-7.

e. Conductor Splicing and Termination

- 1) **Connectors**

All spliced solid field conductors shall be twisted together and secured using vinyl, water-tight, spring tensioned, silicone filled, direct burial wire connectors, as described in LADOT Specification 56-002-03 (latest revision). At least 36 inches of surplus signal cable shall be neatly coiled in a clockwise direction within each pull box. Of these 36 inches of cable, only 24 inches of outer jacket shall be removed. The remaining 12 inches of cable shall remain enclosed within the outer jacket for future emergency repair needs. Care shall be used in removing the outer cable jacket to ensure that the individual conductor insulation is not cut or nicked. Failure to protect the individual conductor insulation shall result in the replacement of the damaged cable at contractor’s expense.
- 2) **Multi-Conductor Signal Cables in the Controller Pull Box**

The installation of new multi-conductor cable(s) into and through the controller pull box shall be spliced together as referenced in paragraph 1) and not looped through, except for:

 - a) Service wires
 - b) Communication cables
 - c) Loop detector lead-in cables
 - d) Railroad preemption cables or wires
 - e) Telephone interconnect cables
 - f) Video cables or conductors
- 3) All stranded wires shall be terminated with an LADOT approved terminal connector and properly compressed for minimum resistance at the attachment.
- 4) Where optimum operation of circuits requires minimum resistance, as determined by the LADOT Traffic Signal Inspector, the connections and

terminals shall be soldered.

f. Inductive Loop Detector Lead-in Cable

All inductive loop detector lead-in cable from the pull box to the controller cabinet shall have two-, three- or four-pair conductors and shall conform to Standard Drawing S-70.2. and LADOT Specification 92-082-03 (latest revision). A maximum of 12” of outer jacket shall be removed.

g. Transit Bus or Photo Red-Light Detector Lead-in Cable

All Transit Bus or Photo Red-Light detector lead-in cable from the pull box to the controller cabinet shall be one pair cable and conform to IMSA Specification 50-2.

h. Conductors Attached to Controller Field Terminals

Each controller field terminal shall have a maximum of one wire connected. If the intersection wiring plan requires more than the single wire to accomplish the correct operation, splicing the conductors in the controller pull box shall be used.

- 1) Compression terminal connectors shall not be used when connecting solid wires to controller terminals.
- 2) Compression terminal connectors shall be used when connecting stranded wires to controller terminals, and shall be soldered.

i. Field Testing

Prior to start of functional testing, the Contractor shall perform the following tests on all circuits, in the presence of the DOT Inspector and/or Engineer.

- 1) **Continuity:** Each circuit shall be tested for continuity. When 120V AC is used to conduct a “dynamic, non-destructive” test of the circuit(s), then suitable circuit protection shall be used. Suitable circuit protection shall be in the form of a low amperage fuse or circuit breaker with a design curve that reacts fast enough to trip and protect the circuit under test without interrupting any of the cabinet circuit breakers.
- 2) **Ground:** Each circuit shall be tested for grounds.
- 3) **Insulation Resistance:** An insulation resistance test at 500 Volts DC shall be made on each circuit between the circuit and a ground. The insulation resistance shall not be less than 10 Megohms on all circuits, except for inductive loop detector circuits, which shall have an insulation resistance value of not less than 100 Megohms.

5. FIBER OPTIC CABLE

a. General

- 1) **Description:** Fiber Optic Trunk Cable shall be of loose-tube construction. The optical fibers shall be single mode optical glass or as specified by the Engineer. The fiber optic cable shall conform to ICEA S-87-640.
- 2) **Performance:** The optical performance of each single-mode fiber measured at wave lengths of both 1310 nanometers and 1550 nanometers shall have maximum attenuation of 0.4 decibels per kilometer at 1310 nanometers and 0.3 decibels per kilometer at 1550 nanometers and shall conform to TIA/EIA 49Z C4AA.
- 3) **Construction:** The cable shall be constructed using five or six gel-filled, color-coded buffer tubes stranded (reverse oscillation) around a dielectric central member. The color-coded fibers shall be contained in the buffer tubes and the remaining fillers shall be natural or white in color. A layer of aramid yarn (e.g. Kevlar) shall hold the tubes in position around the central member and provide tensile strength. The color code for the fibers shall be blue, orange, green brown, slate and white. Water blocking shall be of the dry-tape type within the interstitial spaces, and gel within the buffer tubes.
- 4) **Jacket:** The filled cable core shall be covered with a black, medium density polyethylene jacket. This outer jacket shall be abrasion and crack resistant, non-nutrient to fungus, electronically non-conductive and compatible with all cable components to which it may come in contact. The jacket shall be free from holes, splits, blisters or other imperfections.
- 5) **End Termination Cable:** Shall be of the tight-buffered type and shall contain two single-mode fibers protected by a yellow jacket and aramid yarn (e.g. Kevlar) strength member. The length of a typical end termination cable shall not exceed 100 feet. Connectors for end termination cables shall be ST unless otherwise specified by the Engineer.
- 6) **Identification:** Each length of cable shall be permanently identified by specifying the manufacturer and type of cable at intervals not greater than six feet along the outside of the outer jacket. Each length of cable shall be permanently marked with foot (or meter) markings at intervals not greater than three feet (or one meter).
- 7) **Reels:** The cable shall be wound on standard reels in a manner which provides access to both ends of the cable for testing while the cable is still on the reel.
- 8) **Installation:** Cable installation and handling procedures shall be in accordance with accepted industry standards and/or manufacturer's recommendations and shall be performed by adequately trained and certified personnel. In all type 3 pull boxes, there shall be 10 feet minimum of extra looped cable for each cable entering or leaving the box.

b. Splicing of Fiber Optic Cable

Splicing of the Fiber Optic Cable shall be done by the fusion technique. All cables shall be carefully prepared and spliced in accordance with the cable manufacturer's recommendations. Either heat shrinkable tubing shall protect the finished splices, metal protective sleeves or by some other method approved by the Engineer. All splices must be tested and documented after encasement. No splice shall exceed a 0.05 decibel loss.

The completed splices shall be enclosed in re-enterable splice enclosures that seal to form moisture resistant protection. The splice case or enclosure shall contain a removable splice organizer or crib that shall secure the individual fibers and protect the splices. The splice organizer shall be attached to the strength members in the fiber optic cable. There shall be adequate space inside the enclosure to hold at least three feet of buffer tubes from each cable. There shall be no splices except as authorized by the LADOT Traffic Signal Inspector. Splice enclosures shall be Corning 6C22-02 (or equivalent) unless otherwise authorized by the LADOT Traffic Signal Inspector. Fiber optic interconnect cables may only be spliced at special fiber optics splice boxes as shown on the plans. Video fiber optic cable shall be spliced in double-deep, type 3 pull boxes.

6. CONTROLLER

The contractor-supplied controllers shall conform to the latest LADOT material specification and addendum for the Model 2070 controller assembly, with either Type 332 or 337 cabinet as shown on the traffic signal plan, and all auxiliary equipment required to provide a complete functioning controller per LADOT Specifications 054-053-07 (latest revision).

7. GROUND RODS

Copper ground rods shall be installed in all controller foundations and all service pull boxes. For a post-top mounted controller cabinet on existing or new F-8 foundation, an 8-foot by ½-inch diameter ground rod shall be installed in the controller pull box. For a Type 332 cabinet on F-332 foundation, an 8-foot by ½-inch diameter ground rod shall be installed in the foundation. For a Type M communication cabinet on F-12A foundation, an 8-foot by ½-inch diameter ground rod shall be installed in the foundation. A green #8 AWG copper wire (solid or stranded) shall be connected from the cabinet "Equipment Ground Bus" bar to the ground rod in the foundation or in RARE CASES as approved by the LADOT Traffic Signal Inspector, the controller pull box. The connection device to the ground rod shall be appropriate for the copper wire used.

8. SERVICE

- a. Service conductors shall be continuous without splices from the service pull box to the controller service connection.
- b. A voltage measurement shall be made between the service hot and neutral terminals before the main circuit breaker in the controller assembly.

If the voltage is less than 110 volts AC notify the LADOT traffic signal inspector.

- c. A resistance measurement shall be made between the service neutral terminal and the chassis ground terminal.

If the resistance is more than 4.0 ohms notify the LADOT traffic signal inspector.

9. SIGNAL HEADS

- a. Vehicle and Pedestrian Signal Heads Covers
Shall conform to LADOT Specification 92-086-03 (latest revision).
- b. Vehicle Heads
 - 1) Each signal section housing shall conform to LADOT Specification 92-061-06 (latest revision) for Vehicle Signal Heads, 8-inch and 12-inch glass filled polycarbonate.
 - 2) A minimum of two vehicle heads for each and every phase shall be in operation while work is being performed at the intersection. Non-functioning vehicle heads shall be covered or turned away from the intersection
- c. Pedestrian Heads
 - 1) Each pedestrian signal housing shall conform to LADOT Specification 92-064-06 (latest revision) for Pedestrian Signal Heads, glass filled polycarbonate.
 - 2) One visible operating pedestrian head shall be provided at all times for each direction of each signalized crosswalk while work is being performed at the intersection. Non-functioning pedestrian heads at a signalized crosswalk shall be covered or turned away from the intersection.
- d. Traffic Signal Visors – All vehicle signal indications shall be provided with removable visors per LADOT Specification 92-061-06 (latest revision). If beveled or long visors are specified on the traffic signal plans, they shall conform to Standard Drawings S-76.3, S-76.6 or S-76.7.
- e. Light Emitting Diode (LED) Signal Modules – All new traffic signal modules shall be LED, and shall conform to LADOT Specification 92-088-06 (latest revision).

10. DETECTORS

The contractor shall replace and restore operation of any damaged detectors (inductive loop, video or other type) within two (2) working days after the completion of construction on the portion of the roadway where the detectors were damaged.

Devices other than those identified in the LADOT Specification 54-055-01 (latest revision), must be submitted for test, evaluation, and approval to the LADOT Traffic Signal Lab Research and Development Section, at least 90 days prior to expected date of activation. Contact the Signal Repair Section Supervisor at (213) 847-2943 for specifications applicable to the device being submitted.

11. LINES AND GRADES

- a) All new or relocated traffic signal work shall be located as per the design plans and engineering specifications.
- b) Any reference to curb line on the plans or in the engineering specifications shall be made once the permanent curb and gutter is installed, prior to excavating any new foundations that are called for on the plans.
- c) Contractor shall assume all responsibility for accuracy of foundation installation, including removal of foundations installed at unacceptable elevations and restoration of the soil prior to reinstallation of proposed foundation, at their own expense.

12. ANCHOR BOLT HEIGHT

See Section 307-10.1 “Standards and Steel Pedestals” in the Standard Specification for Public Works Construction for anchor bolt height requirements.

CABLE 1			
		<i>Identification and Insulation Colors</i>	
<i>Circuit</i>	<i>Signal Phase or Function</i>	<i>Base</i>	<i>Stripe</i>
Vehicle Signals	Phase 2 Red	Red	Silver
	Phase 2 Yellow	Yellow	Silver
	Phase 2 Green	Brown	Silver
Pedestrian Signals	Phase 2 Don't Walk	Red	Silver / Silver
	Phase 2 Walk	Brown	Silver / Silver
Vehicle Signals	Phase 4 Red	Red	Black
	Phase 4 Yellow	Yellow	Black
	Phase 4 Green	Brown	Black
Pedestrian Signals	Phase 4 Don't Walk	Red	Black / Black
	Phase 4 Walk	Brown	Black / Black
Vehicle Signals	Phase 6 Red	Red	Orange
	Phase 6 Yellow	Yellow	Orange
	Phase 6 Green	Brown	Orange
Pedestrian Signals	Phase 6 Don't Walk	Red	Orange / Orange
	Phase 6 Walk	Brown	Orange / Orange
Vehicle Signals	Phase 8 Red	Red	Purple
	Phase 8 Yellow	Yellow	Purple
	Phase 8 Green	Brown	Purple
Pedestrian Signals	Phase 8 Don't Walk	Red	Purple / Purple
	Phase 8 Walk	Brown	Purple / Purple
Pedestrian Push Button	Phase 2 ppb	Blue	Silver
	Phase 4 ppb	Blue	Black
	Phase 6 ppb	Blue	Orange
	Phase 8 ppb	Blue	Purple
	PPB Common	White	Black
Signal Common	Signal Common	White	(none)
Spare	Spare	Black	(none)
Spare	Spare	Black	Red

CABLE 2			
		<i>Identification and Insulation Colors</i>	
<i>Circuit</i>	<i>Signal Phase or Function</i>	<i>Base</i>	<i>Stripe</i>
Vehicle Signals	Phase 1 Red	Red	Silver
	Phase 1 Yellow	Yellow	Silver
	Phase 1 Green	Brown	Silver
Vehicle Signals	Phase 3 Red	Red	Black
	Phase 3 Yellow	Yellow	Black
	Phase 3 Green	Brown	Black
Vehicle Signals	Phase 5 Red	Red	Orange
	Phase 5 Yellow	Yellow	Orange
	Phase 5 Green	Brown	Orange
Vehicle Signals	Phase 7 Red	Red	Purple
	Phase 7 Yellow	Yellow	Purple
	Phase 7 Green	Brown	Purple
Overlap Signals	OLA Red	Red	Silver / Silver
	OLA Yellow	Blue	Silver
	OLA Green	Brown	Silver / Silver
Overlap Signals	OLB Red	Red	Black / Black
	OLB Yellow	Blue	Black
	OLB Green	Brown	Black / Black
Overlap Signals	OLC Red	Red	Orange / Orange
	OLC Yellow	Blue	Orange
	OLC Green	Brown	Orange / Orange
Overlap Signals	OLD Red	Red	Purple / Purple
	OLD Yellow	Blue	Purple
	OLD Green	Brown	Purple / Purple
Spare	Spare	White	Black
Signal Common	Signal Common	White	(none)
Spare	Spare	Black	(none)
Spare	Spare	Black	Red

28-Conductor Cable Color Code Identification

PROPOSED

EXISTING

EXISTING
TO BE REMOVED

			SIGNAL HEAD, THREE 8" (200 MM) SECTION HEADS (Footnote A)
			SIGNAL HEAD, THREE 12" (300 MM) SECTIONS (Footnote A)
			SIGNAL HEAD WITH BEVELED VISOR (LEFT BEVEL SHOWN) (Footnote A)
			SIGNAL STANDARD
			SIGNAL HEAD, THREE 8" (200 MM) SECTIONS WITH LONG VISOR (Footnote A)
			SIGNAL HEAD, FOUR SECTIONS – THREE 8" SECTIONS (R, Y, G) + 12" GREEN ARROW (Footnotes A & B)
			SIGNAL HEAD, FOUR SECTIONS – THREE 12" SECTIONS (R, Y, G) + 12" GREEN ARROW (Footnotes A & B)
			SIGNAL HEAD, THREE SECTIONS – TWO 8" SECTIONS (R, Y) + 12" GREEN UP ARROW (Footnote A)
			SIGNAL HEAD, THREE SECTIONS – ONE 12" SECTION (R) + 12" YELLOW AND GREEN ARROWS (Footnotes A & B)
			SIGNAL HEAD, THREE SECTIONS – 12" RED, YELLOW AND GREEN ARROWS (Footnotes A & B)
			SIGNAL HEAD, FIVE SECTIONS – THREE 8" SECTIONS (R, Y, G) + 12" YELLOW & GREEN ARROWS (Footnotes A & B)
			SIGNAL HEAD, FIVE SECTIONS – THREE 12" SECTIONS (R, Y, G) + 12" YELLOW AND GREEN ARROWS – CLUSTER HEAD IF ON MAST ARM FOR LEFT TURN PHASE (Footnotes A & B)
			SIGNAL HEAD, THREE 12" PROGRAMMED VISIBILITY SECTIONS (R, Y, G) (Footnote A)
			LOUVERED SIGNAL INDICATIONS (8" OR 12"), (FOOTNOTES A, F)

DWN	MT	7-28-11	Title Traffic Signal Symbols	
CKD				
T. E.				
Sr. T. E.				
Pr. T. E.			CITY OF LOS ANGELES DEPARTMENT OF TRANSPORTATION	
Approved		10-28-11	Drawing No.	
			S-50.1	
for		Jaime de la Vega, General Manager		

PROPOSED

EXISTING

EXISTING
TO BE REMOVED

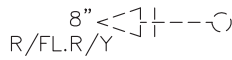

SIGNAL HEAD, THREE 8" SECTIONS—
STEADY RED, FOLLOWED BY FLASHING RED,
FOLLOWED BY STEADY YELLOW (Footnote A)

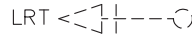

LIGHT RAIL SIGNAL, PER PLAN DETAILS

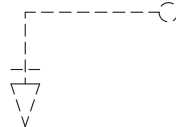
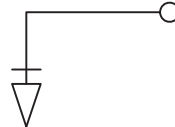

STANDARD WITH MAST ARM AND WITHOUT LUMINAIRE
(Footnotes A & C)

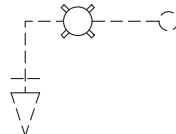
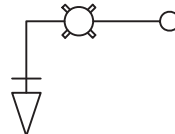
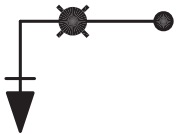

STANDARD WITH MAST ARM AND LUMINAIRE
(Footnotes A & C)

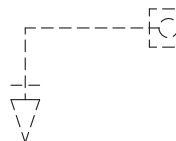
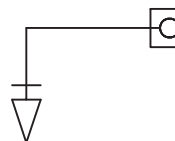
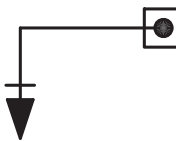

CD954 STANDARD WITH MAST ARM AND WITHOUT
LUMINAIRE; PLATFORM MOUNTED (TEMPORARY SIGNAL)
(Footnotes A & C)

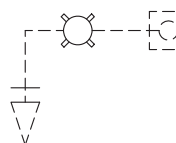
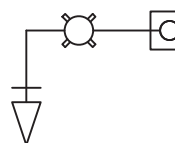
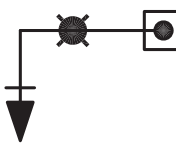

CD954 STANDARD WITH MAST ARM AND LUMINAIRE;
PLATFORM MOUNTED (TEMPORARY SIGNAL)
(Footnotes A & C)



TYPE 1 STANDARD, PLATFORM MOUNTED
(TEMPORARY SIGNAL)

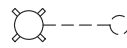
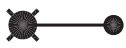

ELECTROLIER, PENDANT TYPE



ELECTROLIER, UPRIGHT TYPE

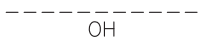
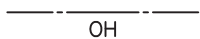
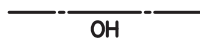

OVERHEAD CABLE



FIBER OPTIC CABLE



SIGNAL CONDUCTORS



FIBER SPLICE VAULT

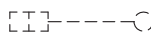

PEDESTRIAN SIGNAL



PEDESTRIAN PUSHBUTTON



EQUESTRIAN PUSHBUTTON
(MOUNTING HEIGHT PER PLAN)



BICYCLIST PUSHBUTTON

APS –INDICATES DEVICE WITH ACCESSIBLE PEDESTRIAN SIGNAL FEATURES

PROPOSED

EXISTING

EXISTING
TO BE REMOVED



TYPE 7 PUSHBUTTON STANDARD (PPB SHOWN)



SIGNAL CONTROLLER CABINET



SIGNAL CONTROLLER WITH GPS TIME RECEIVER



COMMUNICATION CABINET



TYPE 2 PULLBOX



TYPE 3 PULLBOX



STREET LIGHTING PULLBOX

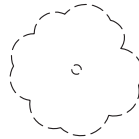

TREE (SHOWING APPROXIMATE OVERHANG)

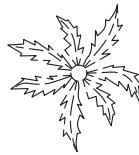

PALM TREE

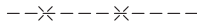

FENCE



TRAFFIC SIGN



SIGN POST



PHOTO ENFORCEMENT POLE



SERVICE POLE
(With Pole Number Listed)



POWER POLE

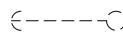

POWER POLE WITH GUY ANCHOR



FIRE HYDRANT

PROPOSED

EXISTING

EXISTING
TO BE REMOVED

C.B.

c.b.

c.b.

CATCH BASIN



MANHOLE



FLASHING BEACON



INDUCTIVE LOOP DETECTOR -6-FOOT DIAMETER



BICYCLE LOOP DETECTOR
PER LADOT STD. DWG. NO. S-70.1D



INDUCTIVE LOOP DETECTOR (SIZE NOTED PER PLAN)

MR
V.
O.
I.



MR
V.
O.
I.



MR
V.
O.
I.



OVERHEAD DETECTOR
MICROWAVE/RADAR (MR), VIDEO (V.), OPTICAL (O.)
INFRARED (I)



VIDEO CAMERA



PHOTO ENFORCEMENT CAMERA



SPREAD SPECTRUM RADIO UNIT



IN ROADWAY LIGHTING





PEDESTRIAN BARRICADE

FOOTNOTES:

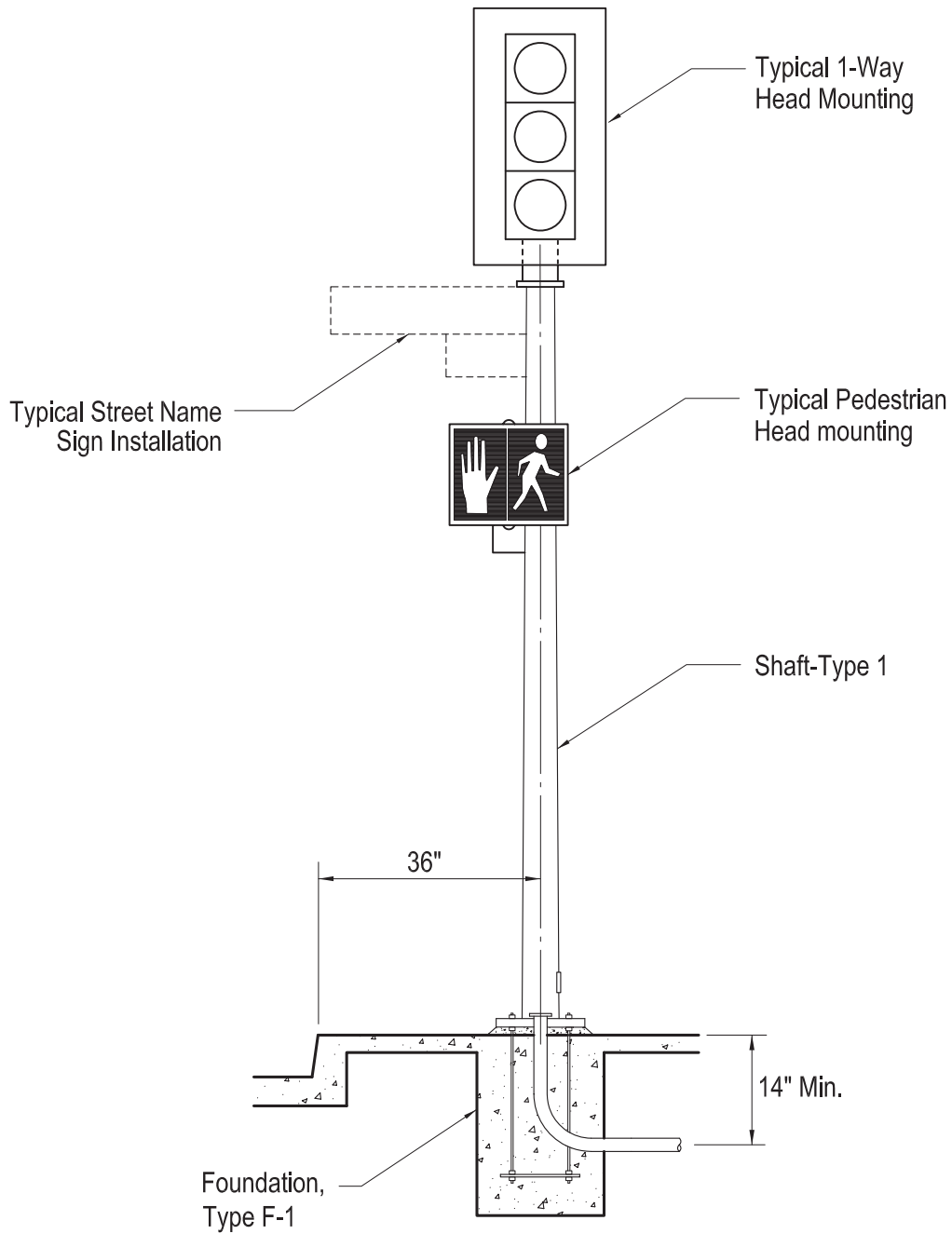
- A. WITH BACKPLATES
- B. SYMBOL SHALL DESIGNATE EITHER RIGHT OR LEFT ARROW(S)
- C. MAST ARM LENGTH SHALL BE 15', UNLESS OTHERWISE NOTED
- D. ALL SIGNAL HEADS SHOWN WITH SIGNAL STANDARD.
- E. PEDESTRIAN SIGNAL AND PUSH BUTTONS SHOWN WITH STANDARD.
- F. FOR SPECIAL APPLICATIONS ONLY.



DWN	MT	3-1-16	Title TYPICAL MOUNTING OF TYPE 1 STANDARD	
CKD				
T. E.	JV	3-3-16		
Sr. T. E.	MA	3-8-16		
Pr. T. E.	VJ	4-11-16	CITY OF LOS ANGELES DEPARTMENT OF TRANSPORTATION	
Approved		 Seleta J. Reynolds, General Manager		4-11-16 Drawing No. S-51.1.2A

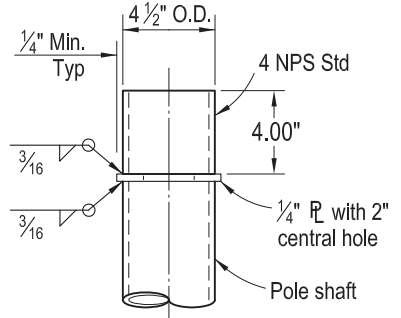
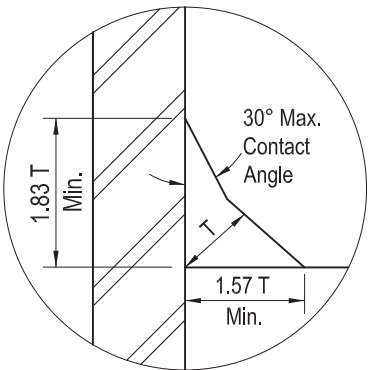
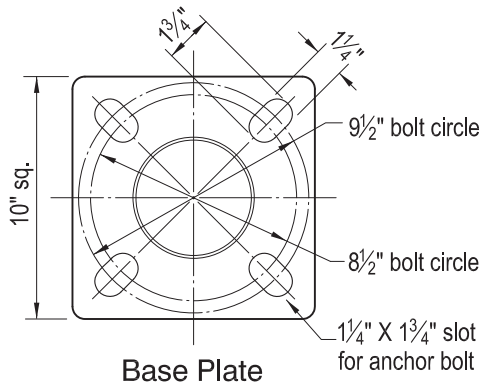

Detail B (Pole Top Tenon)

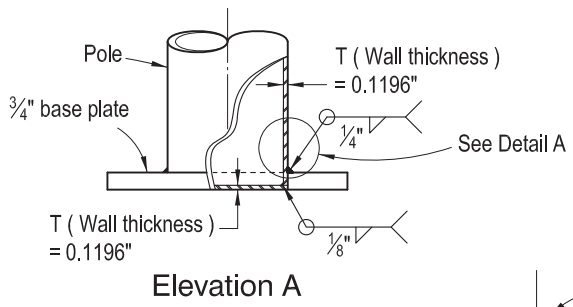

Elevation A

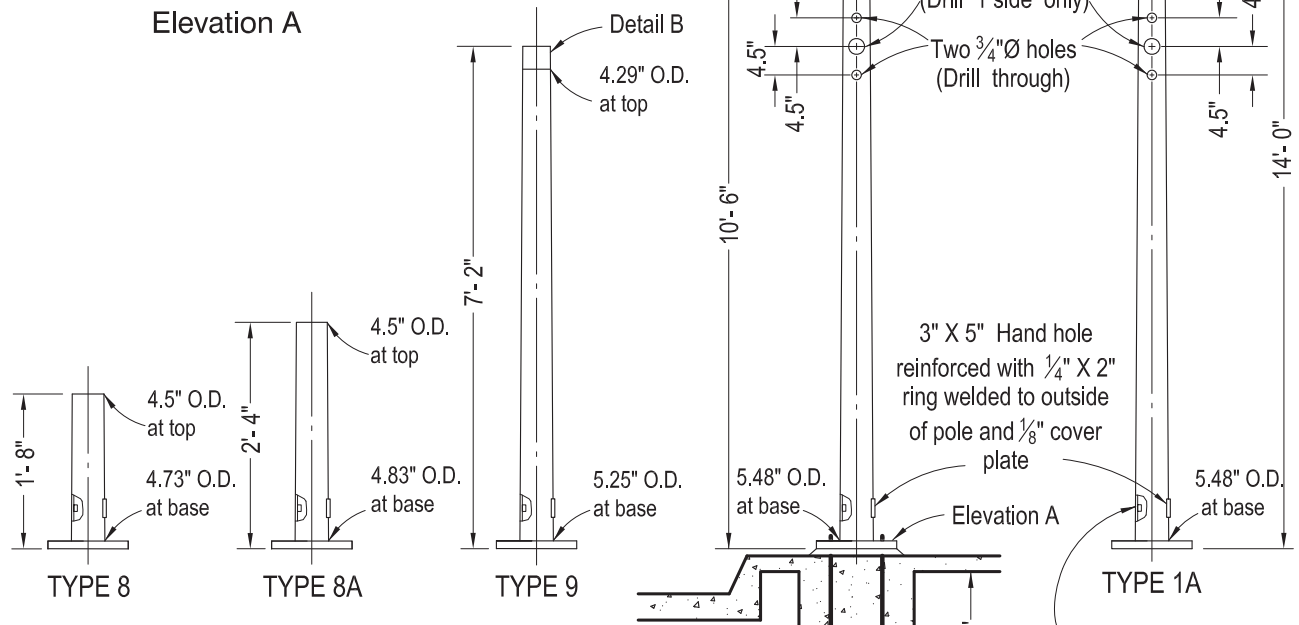
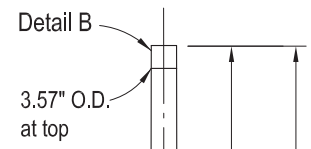

- Notes:
- All standards shall be tapered steel posts with 0.1196" wall thickness.
 - Max. taper of posts shall be 0.143" per foot.

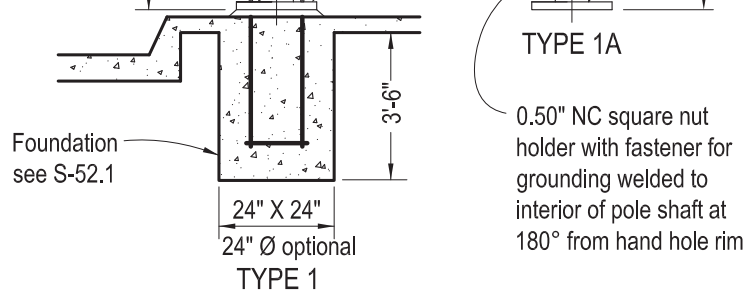

BUREAU OF ENGINEERING
GARY LEE MOORE, PE, ENV SP, CITY ENGINEER

STRUCTURAL DESIGN CHECKED BY: VIGEN GHARIBIAN, SE
APPROVED BY:

Shailesh Patel 8-9-16
SHAILESH PATEL, SE, DIVISION ENGINEER
STRUCTURAL ENGINEERING DIVISION

DWN	MT	8-3-16	Title
REV			
T. E.	JV	8-3-16	STANDARDS TYPE 1, 1A, 8, 8A & 9
Sr. T. E.	MA	8-3-16	
Pr. T. E.	VJ	8-3-16	
Approved			CITY OF LOS ANGELES DEPARTMENT OF TRANSPORTATION
<i>Seleta J. Reynolds</i>			Drawing No.
Seleta J. Reynolds, General Manager			S-51.1.3A

1/1

8-4-16

Notes:

1. Shaft Material: 2½" Std. Schedule 40 Pipe.
2. Finish: Hot dip galvanize after fabrication per ASTM spec. A-120

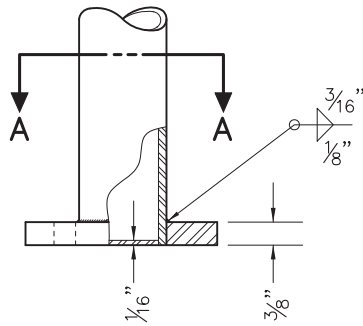

Base Detail

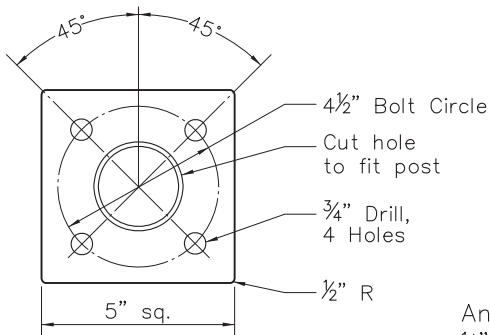

Section A-A

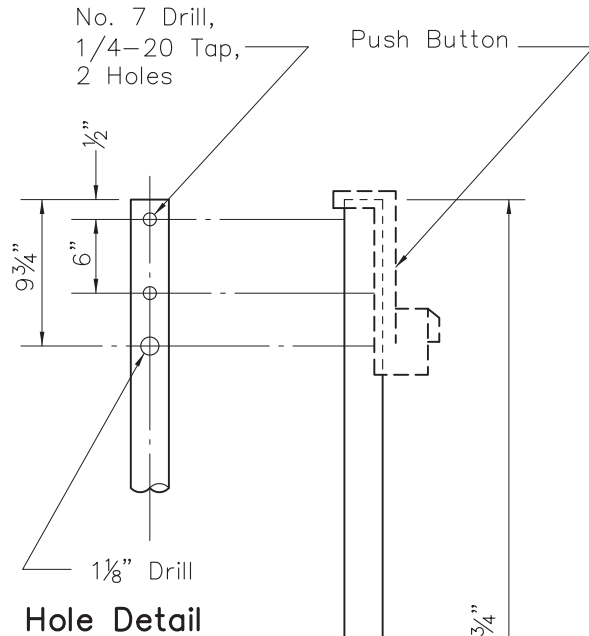

Hole Detail

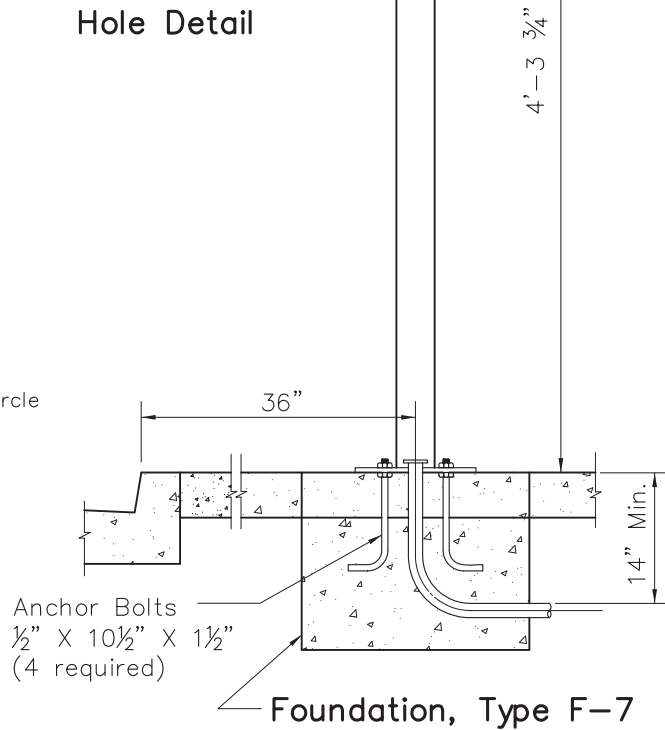

Foundation, Type F-7

DWN	MT	7-09-07	Title STANDARD, TYPE 7 CITY OF LOS ANGELES DEPARTMENT OF TRANSPORTATION
CKD	RAR	2-05-08	
T. E.	JV	2-11-08	
Sr. T. E.	JW	2-13-08	
Pr. T. E.	SFS	2-13-08	
Approved <i>John E. Fisher</i> for Rita L. Robinson, General Manager			June 26, 2008
			Drawing No. S-51.7

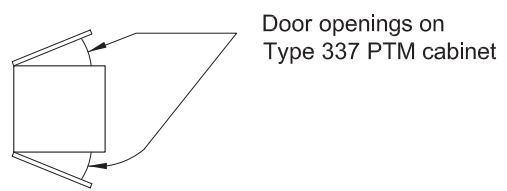
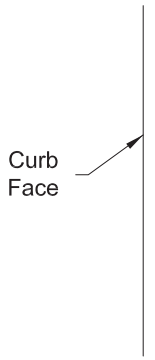

Detail

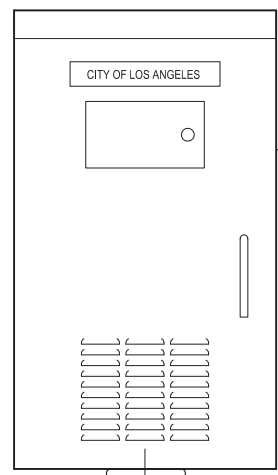

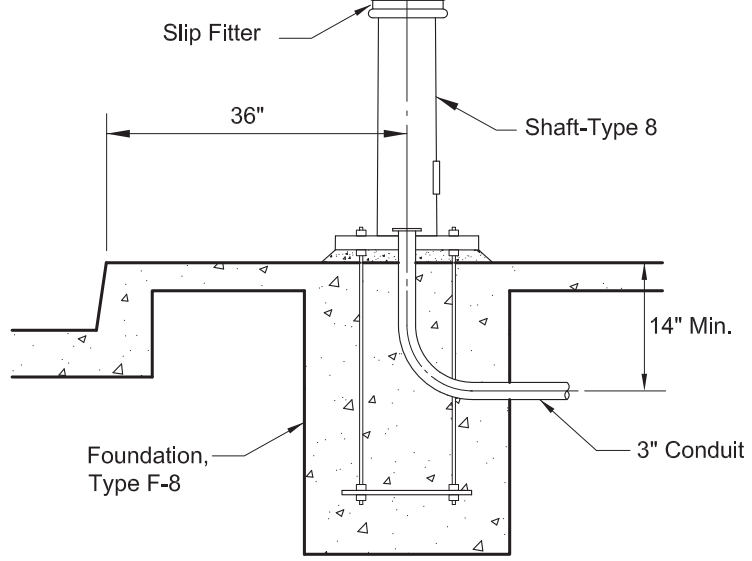

Typical cabinet installation
(Type 337 post-top mounted cabinet)

Note:
Type 337 PTM cabinet
to be mounted with doors perpendicular
to curb and doors swing towards curb.
See detail upper left.

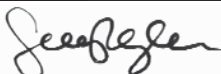

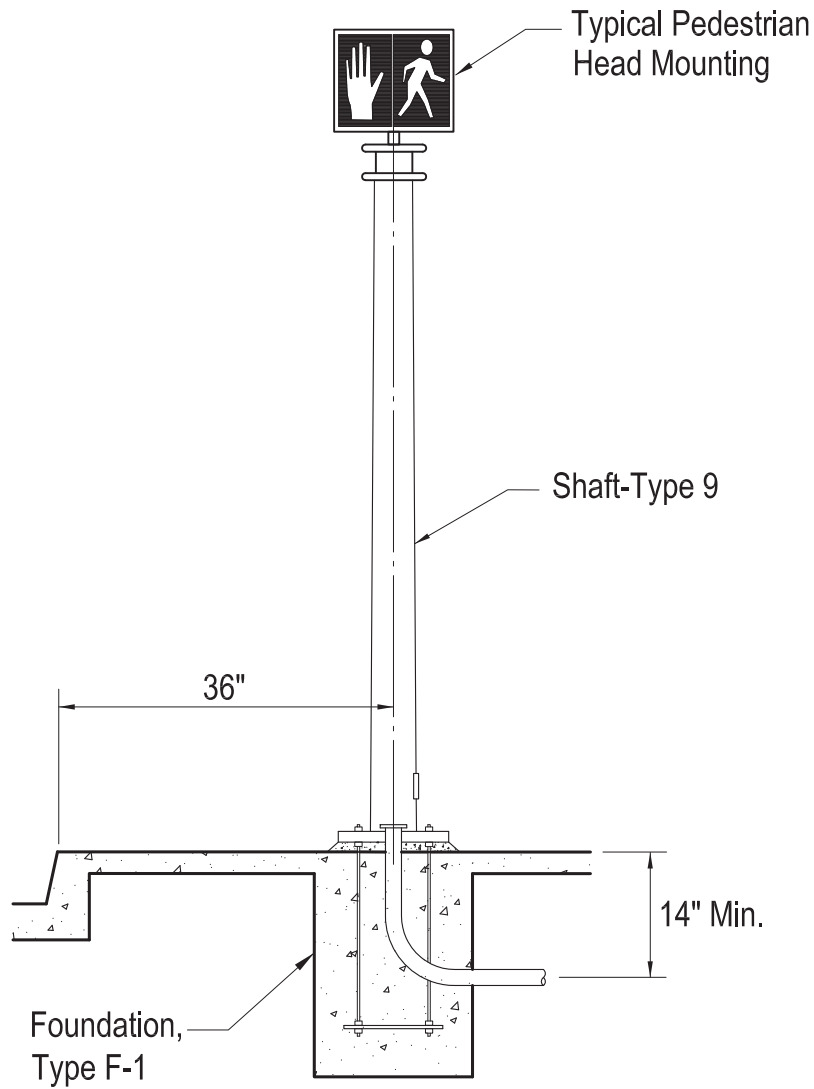
DWN	MT	3-1-16	Title TYPE 337 POST-TOP MOUNTED CABINET	1/1
CKD				
T. E.	JV	3-3-16		
Sr. T. E.	MA	3-8-16		
Pr. T. E.	VJ	4-11-16		
CITY OF LOS ANGELES DEPARTMENT OF TRANSPORTATION				
Approved		 Seleta J. Reynolds, General Manager		Drawing No. S-51.8

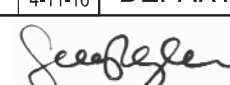

DWN	MT	3-1-16	Title MOUNTING OF TYPE 9 STANDARD	
CKD				
T. E.	JV	3-3-16		
Sr. T. E.	MA	3-8-16		
Pr. T. E.	VJ	4-11-16	CITY OF LOS ANGELES DEPARTMENT OF TRANSPORTATION	
Approved		 Seleta J. Reynolds, General Manager		Drawing No. S-51.9A

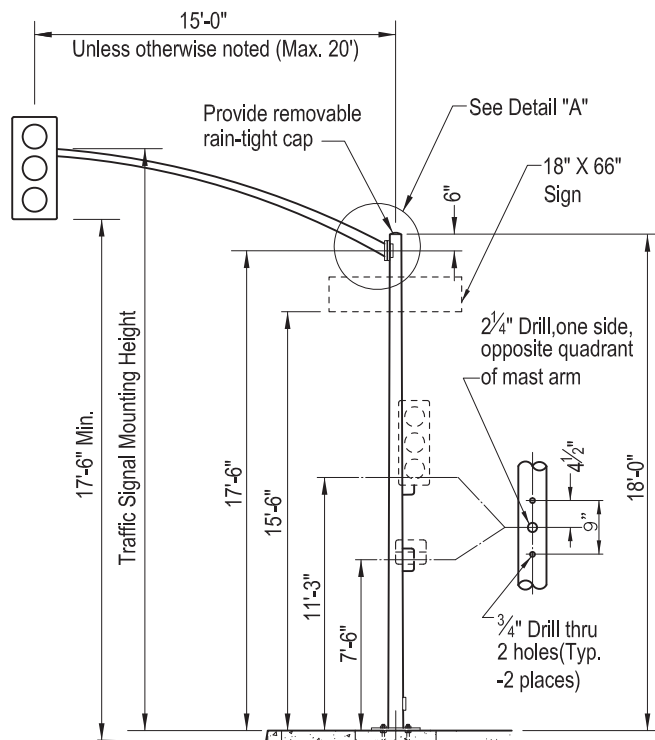

Note:
Top 3" of foundation to be poured level with sidewalk except on structures.

- ② Anchor Bolt 1 1/8" X 40" ASTM A307
- Foundation, Type F-2 (S-52.2) 32" X 32" X (48"+4" Topping) 560-C-3250 Conc.

POLE SCHEDULE				SIGNAL ARM DATA ①			
HGT.	ROUND TAPERED STEEL POLE		SIGNAL ARM LENGTH	PROJECTED LENGTH	GAGE	MINIMUM O.D. @ POLE	MOUNTING HEIGHT
	GAGE	MIN. O.D. BASE TOP					
18.0'	10 GA.	7 3/4" 5 1/2"	15' - 20'	15'-0"	10 GA.	4.6"	22.3±'
				18'-0"		5.2"	
				20'-0"	7 GA.	5.0"	23.3±'

Notes:

- ① Round tapered steel tube with maximum taper of .15 inches per foot. End section O.D. of 2 3/8" for mounting hardware. Standard 2" pipe extensions of 3'-0" max. length may be used at the option of the manufacturer.
- ② 4 anchor bolts each base plate. Length indicated does not include required 4"-90° bend. Each anchor bolt is threaded 6" at the top and is furnished with 2 nuts & 2 washers. One anchor bolt bonded to conduit.
- 1. Pole and signal arm shall be fabricated from sheet steel conforming to the specifications of ASTM Designation A611 Grade C, or ASTM Designation A 570 Grade C.
- 2. All welding shall conform to AWS D2.0 "Specifications for welded Highway and Railway Bridges."
- 3. All structural steel shall conform to ASTM designation A36, except as otherwise shown.

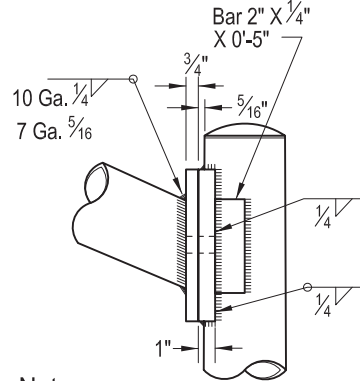
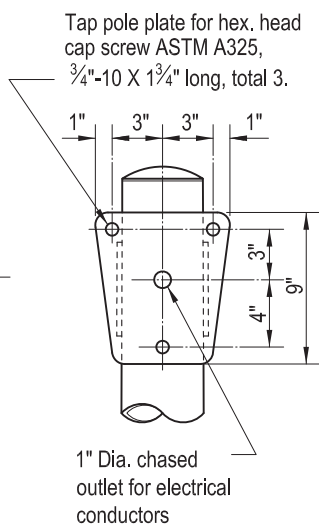

Note:
Dimensions shown here apply to both the post and signal arm plate

Detail "A"
Not to scale

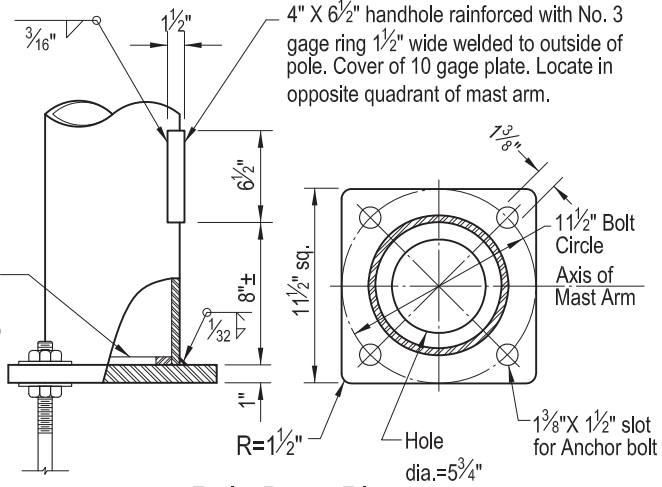

Pole Base Plate
No Scale

Notes:

- 1. Alternative details approved by the Engineer may be subst. for the arm connections and configurations shown.
- 2. Fabricators electing to use larger than min. arm diameters must adjust the details as required to permit solid seating of cap screws.
- 3. In lieu of the torque requirements for HS bolts, cap screws shall be tightened by the turn-of-nut method 1/6 turn from snug tight condition. No washer will be required.
- 4. Only one signal head may be mounted on each signal arm.
- 5. All metal parts shall be galvanized after fabrication.
- 6. All arms shall be bent to the approximate configuration shown.

Drawn By		Title	▽	STANDARD, TYPE 16
Checked By				
Supervised By				
Reviewed By				
Revisions				CITY OF LOS ANGELES DEPARTMENT OF TRANSPORTATION Frances T. Banerjee, General Manager
Updated	▽	RO	4-3-82	Approved Nov. 13, 1998
Updated	▽	GH	3-27-92	
BRIDGE AND STRUCTURAL DESIGN DIVISION				DRAWING NO.
CHECKED FOR STRUCTURAL DESIGN				S - 51.9.5
DIV. ENGR. <i>Philip H. Skarin</i>				
DATE August 7, 1973				

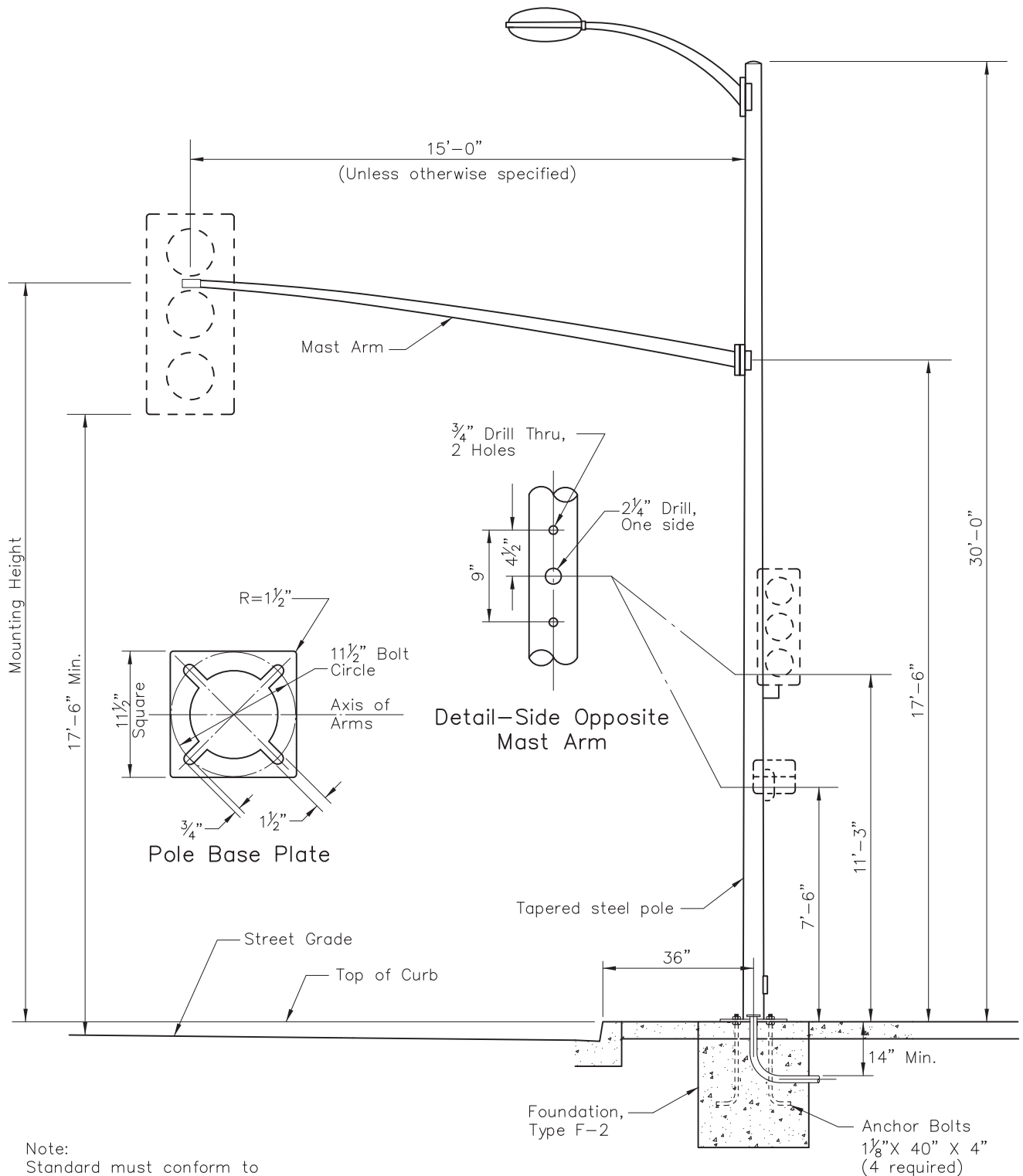

Note:
Standard must conform to
Bureau of Street Lighting
Plan L-103-0

Mast Arm Length	Mounting Height
15'	22.3'±
18'	23.3'±
20'	23.3'±

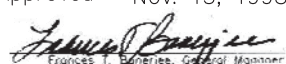
Drawn By	MT	11-72	Title	CD954 STANDARD	
Checked By					
Supervised By					
Reviewed By			CITY OF LOS ANGELES DEPARTMENT OF TRANSPORTATION Frances T. Banerjee, General Manager		
Revisions					
Updated RO, JF	JAC	11-3-82	Approved	Nov. 13, 1998	DRAWING NO.
Title & Table	GH	5-31-90	 Frances T. Banerjee, General Manager		S-51.9.6

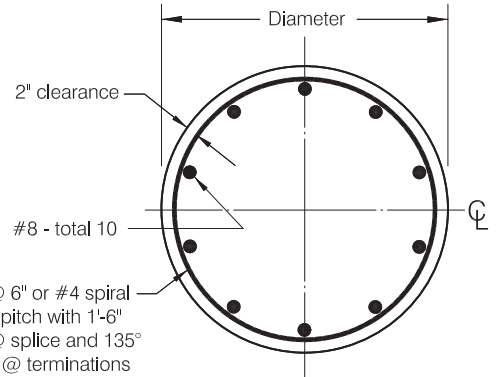
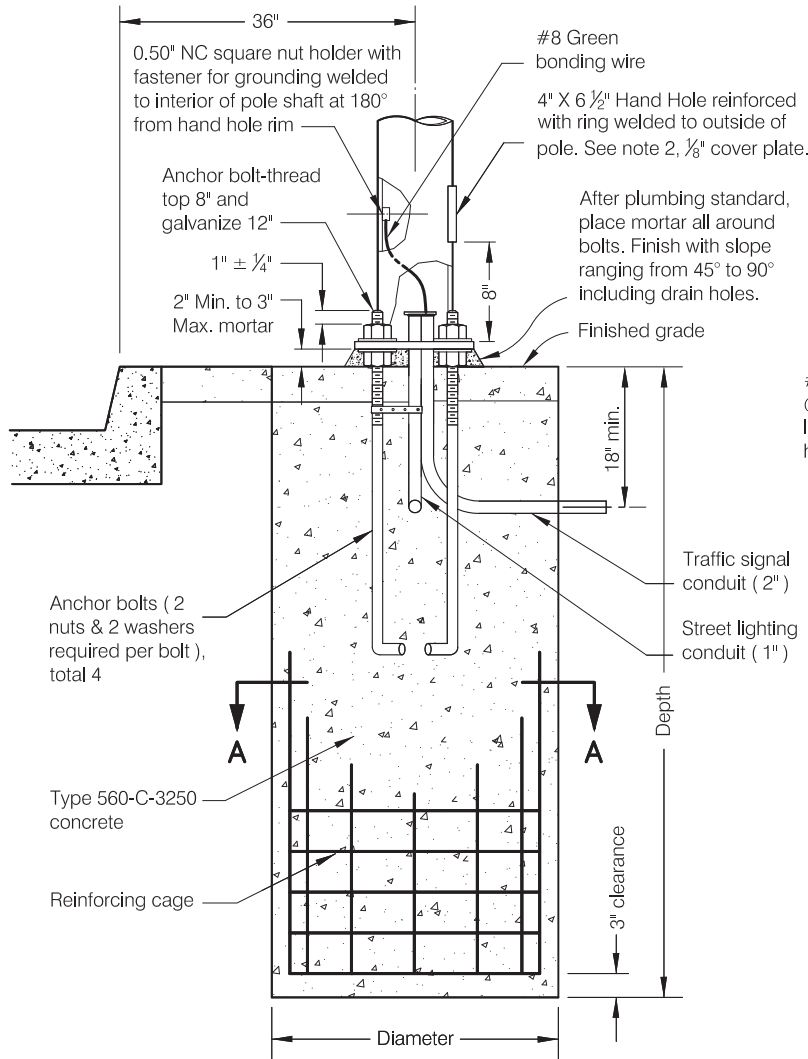

SECTION A-A
CAST-IN-DRILLED-HOLE (CIDH)
PILE FOUNDATION

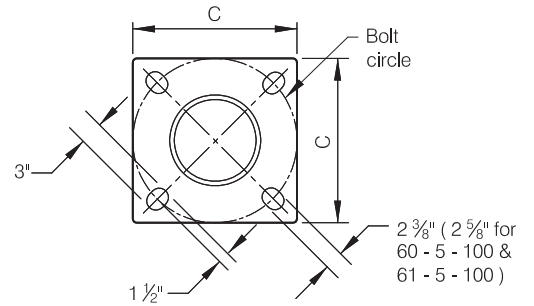

BASE PLATE

TYPE	Standard Height	Mast Arm Length	" F " Min. Spacing	CIDH Pile Foundation				Anchor Bolts	Bolt Circle	C
				Dia.	Depth	Cage Dia.	Cage Depth			
16 - 3 - 100	18.5'	15' or 20'	8'	36"	9'	32"	8' - 6"	2"Ø X 42" X 6"	18"	18"
17 - 3 - 100	30'									
18 - 4 - 100	17'	25' or 30'	12'							
19 - 4 - 100	30'									
23 - 4 - 100	17'	35'	14'							
24 - 4 - 100	30'									
26 - 4 - 100	30'									
27 - 4 - 100	17'	40' or 45'	15'							
28 - 5 - 100	30'									
29 - 5 - 100	30'	50' or 55'	F1 = 15'							
60 - 5 - 100	17'	60' or 65'	F2 = 12'	16'	15' - 6"	2 1/4"Ø X 60" X 6"	23"	23"		
61 - 5 - 100	30'									

Notes:

- Fabrication of the standards shall conform to the 2006 State of California Department of Transportation Standard Plans.
- Hand Hole reinforcement ring shall be 1/4" X 2" for 0.1196" to 0.2391" thick poles, 3/8" X 2" for 0.3125" thick poles.
- Base plate to be fabricated as shown.
- Luminaire Arm Length per Street Lighting Sheet.
- Standard to be pre-drilled as shown.
- Attach stamped metal tag above hand hole on pole and on mast arm (minimum 1/4" height numbers see sheet 2).
- * Fabricate and install with 18" bolt circle.

DWN	MT	9-30-15	Title 100 MPH Poles 1/2
CKD			
T. E.	JV	9-30-15	
Sr. T. E.	MA	10-1-15	
Pr. T. E.	VJ	10-2-15	
Approved <i>Seleta J. Reynolds</i> Seleta J. Reynolds, General Manager			11-20-15
			Drawing No. S-52.1.6

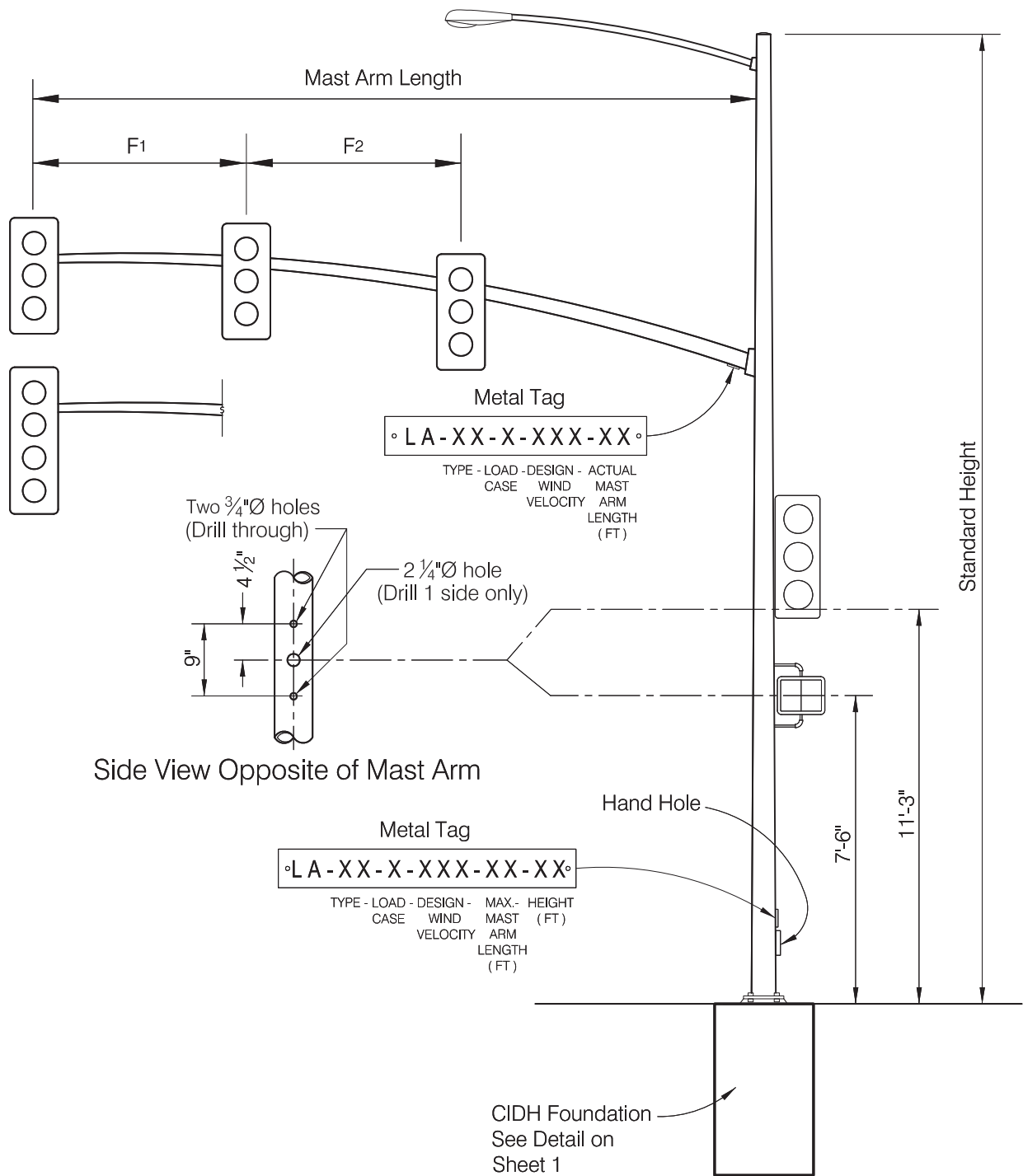

Side Mount Indications Drill Detail

SIDE-MOUNT OPTION
(SEE CLAMP & SIDE MOUNTED
CAMERA ARM DETAIL - SHEET 2)

UPPER HANDHOLE AND COUPLING
(SEE DETAIL - SHEET 2)

TOP-MOUNT OPTION (SEE
PAN & TILT MOUNTING
FLANGE DETAIL - SHEET 2)

TYPE C-1-100 POLE

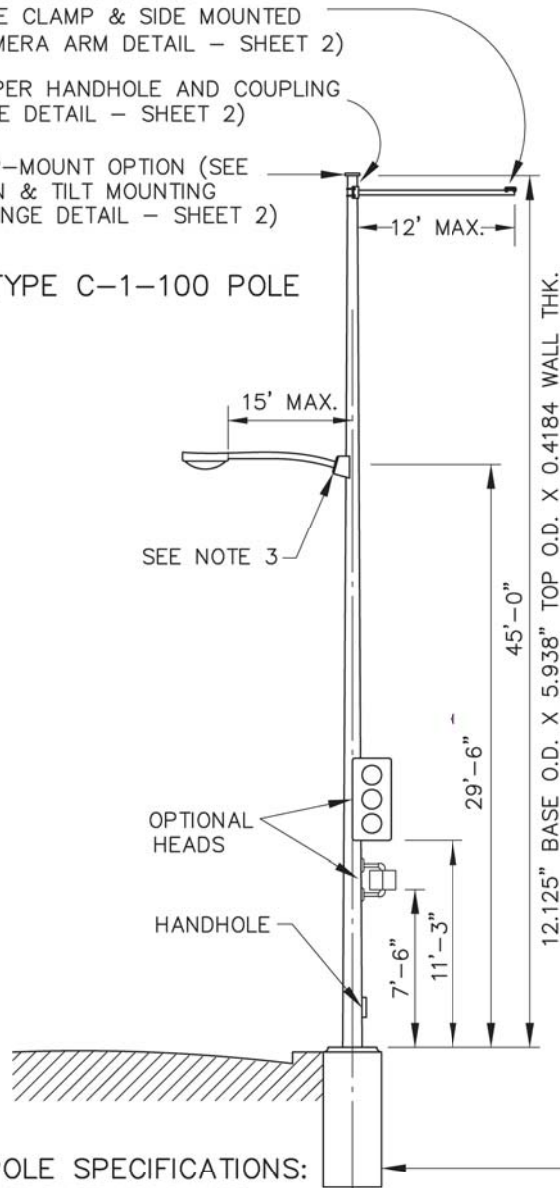

SIDE-MOUNT OPTION
(SEE CLAMP & SIDE MOUNTED
CAMERA ARM DETAIL - SHEET 2)

UPPER HANDHOLE AND COUPLING
(SEE DETAIL - SHEET 2)

TOP-MOUNT OPTION (SEE
PAN & TILT MOUNTING
FLANGE DETAIL - SHEET 2)

TYPE C-2-100 POLE

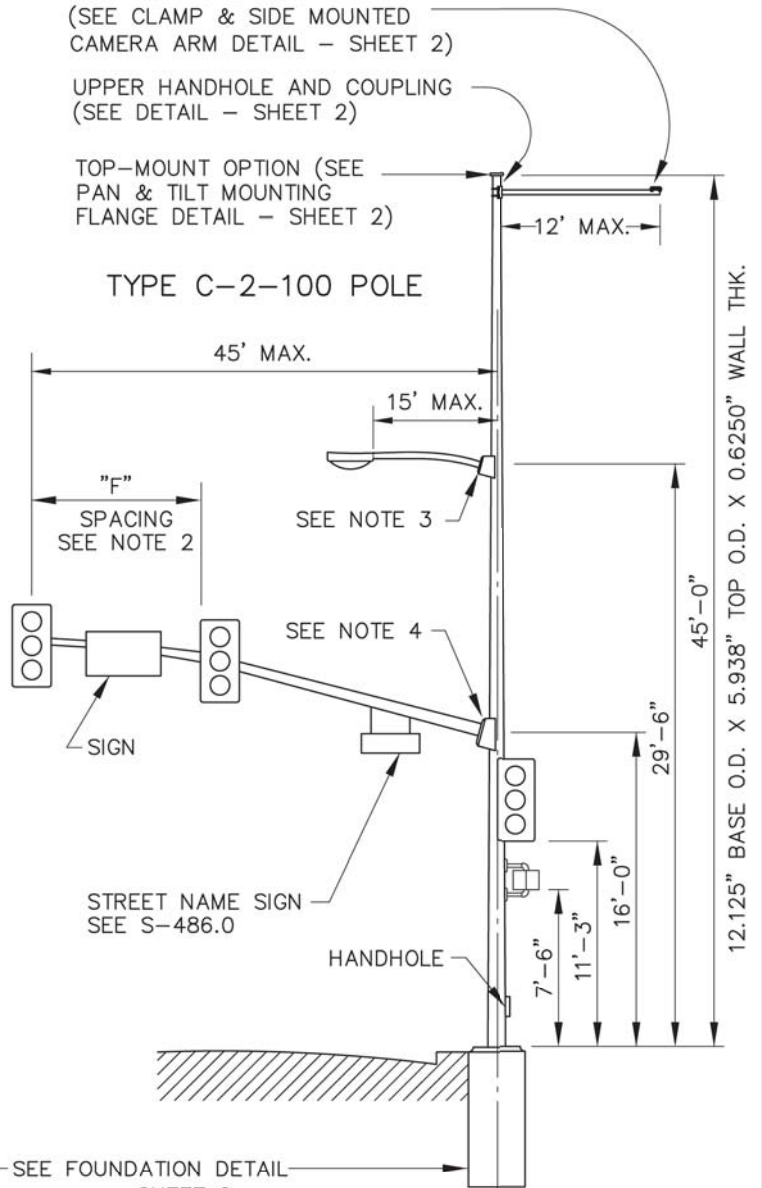

POLE SPECIFICATIONS:

BASE PLATE AND FLANGES:

ASTM A-36

SHAFT: STEEL OF 48,000 PSI
MINIMUM YIELD AFTER FABRICATION.
DESIGN YIELD OF $F_y = 48,000$ PSI IN
ORDER THAT $F_u/F_y > 1.5$

PIPE: ASTM A-53 GRADE B

ANCHOR BOLTS: ASTM A-307

WELDS: ALL BUTT WELDS TO BE
GROUND FLUSH WITH BASE METAL

LONGITUDINAL: BUTT WELD BY
THE SUBMERGED ARC PROCESS

CIRCUMFERENTIAL: BUTT WELD
WITH PERMANENT BACK-UP RING

FINISH POLE: HOT-DIP

GALVANIZED PER ASTM A-123

FINISH HARDWARE: HOT-DIP

GALVANIZED PER ASTM A-153

SEE FOUNDATION DETAIL
-SHEET 2

GENERAL NOTES:

1. FABRICATION OF THE STANDARDS, LUMINAIRE ARMS AND MAST ARMS MUST CONFORM TO THE 2006 DEPARTMENT OF TRANSPORTATION, STATE OF CALIFORNIA STANDARD PLANS.
2. REFER TO LADOT STANDARD DWG. NO. S-52.1.6 FOR "F" SPACING.
3. PROJECTED LUMINAIRE ARM LENGTH TO BE DETERMINED BY DEPARTMENT OF PUBLIC WORKS, BUREAU OF STREET LIGHTING. REFER TO CALTRANS STANDARD DWG. NO. ES-7C FOR LUMINAIRE ARM CONNECTION DETAIL.
4. SIGNAL ARM CONNECTION SHALL BE FOR 45 FT. ARM (CASE 4 ARM LOADING), AS PER CALTRANS STANDARD DWG. NO. ES-7F. SHORTER ARMS MAY BE USED, AS APPROPRIATE.

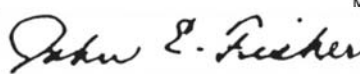
DWN	MT	11-15-07	Title	Camera Poles (1/2) (CASE 4 MAST ARM LOADING - 100 MPH WIND SPEED)
CKD				
T. E.	NA	3-11-08		
Sr. T. E.	JEM	3-11-08	CITY OF LOS ANGELES	
Pr. T. E.	SS	3-12-08	DEPARTMENT OF TRANSPORTATION	
Approved			March 18, 2008	Drawing No.
 for Rita L. Robinson, General Manager			S-52.1.4B	

Approved by: *Shailesh Patel* Date: *11-29-07*
 SHAILESH PATEL, S. E.
 Division Engineer
 Structural Engineering Division
 Bureau of Engineering

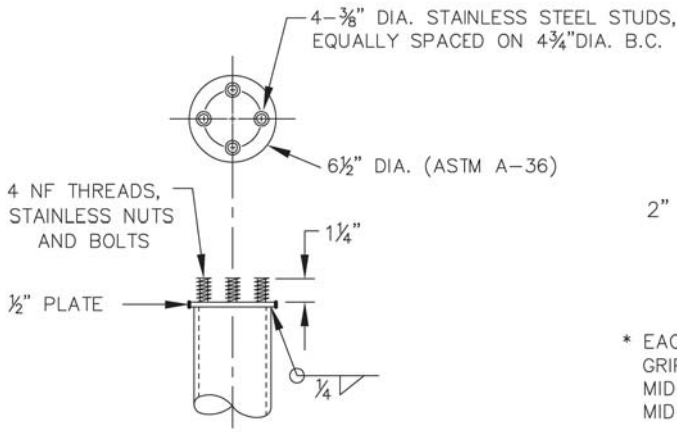

PAN & TILT MOUNTING FLANGE DETAIL

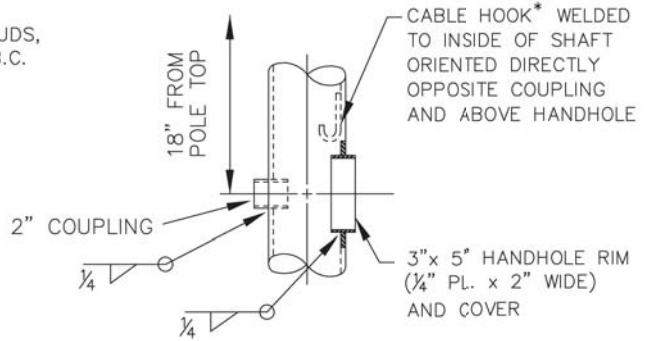

* EACH CABLE SHALL BE SUPPORTED INSIDE THE POLE BY KELLIMS GRIPS (OR EQUIVALENT) ONE AT THE TOP AND A SECOND AT THE MID-POINT. TWO 1/8" DIA. GALVANIZED STEEL WIRES SHALL SECURE MID-POINT GRIPS TO THE TOP CABLE HOOK.

UPPER HANDHOLE & COUPLING DETAIL

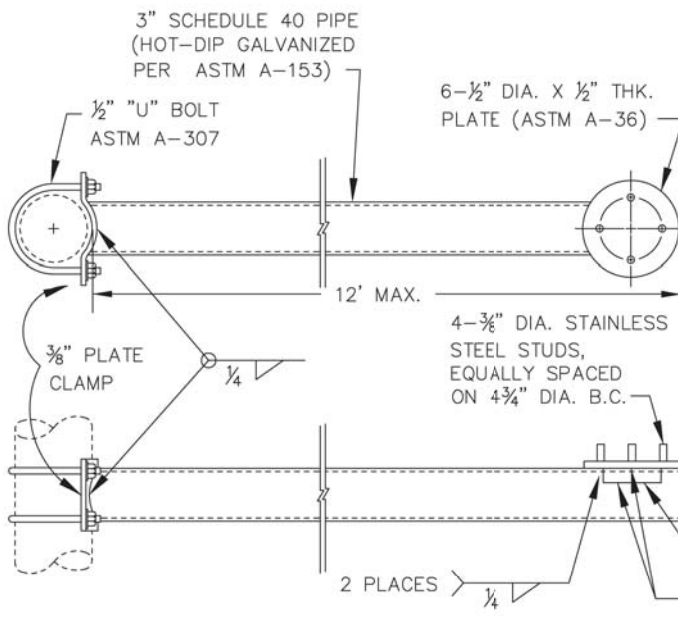

CLAMP & SIDE MOUNTED CAMERA ARM DETAIL

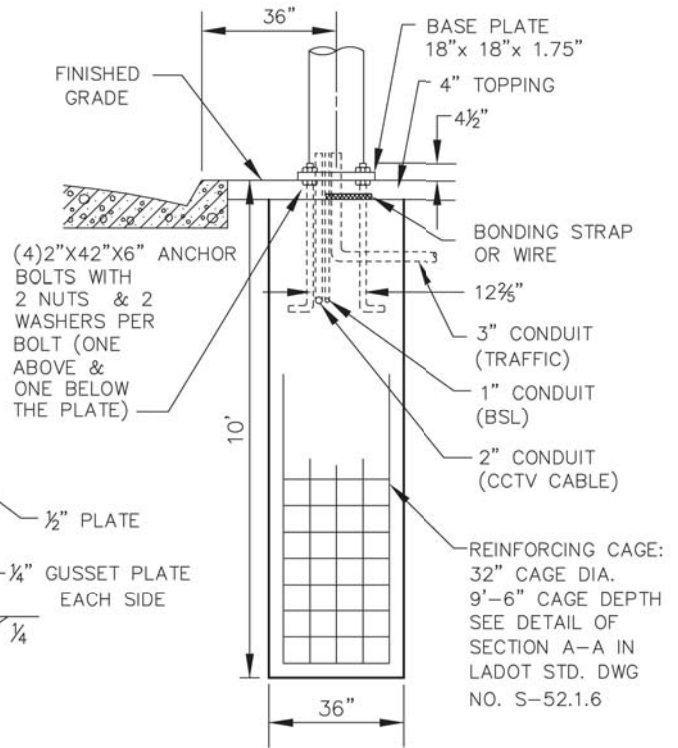

FOUNDATION DETAIL

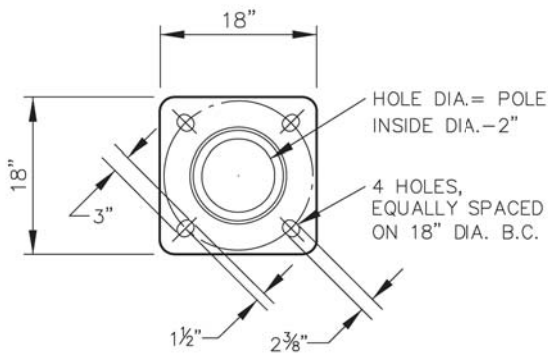

BASE PLATE DETAIL

FOUNDATION DESIGN CRITERIA:

WIND LOAD DESIGN BASED ON 2001 AASHTO STANDARD SPECIFICATIONS FOR STRUCTURAL SUPPORT FOR HIGHWAY SIGNS, LUMINAIRES, AND TRAFFIC SIGNALS. (FATIGUE REQUIREMENTS OF CHAPTER 11 ARE NOT CONSIDERED.) WIND SPEED = 100 MPH

NOTES:

1. BAR REINFORCEMENT SHALL CONFORM TO ASTM A615 GRADE 60.
2. ALL SOILS SUPPORTING AND SURROUNDING THE FOUNDATION SHALL BE UNDISTURBED NATURAL SOIL OR 90% COMPACTED FILL.
3. FOUNDATION CONCRETE SHALL BE 560-C-3250.

CITY OF LOS ANGELES
DEPARTMENT OF TRANSPORTATION

Title **Camera Poles**
(CASE 4 MAST ARM LOADING - 100 MPH WIND SPEED)

2/2

Drawing No.
S-52.1.4B

Tilt solar panel to 60° and rotate assembly so collector panel will face due south.

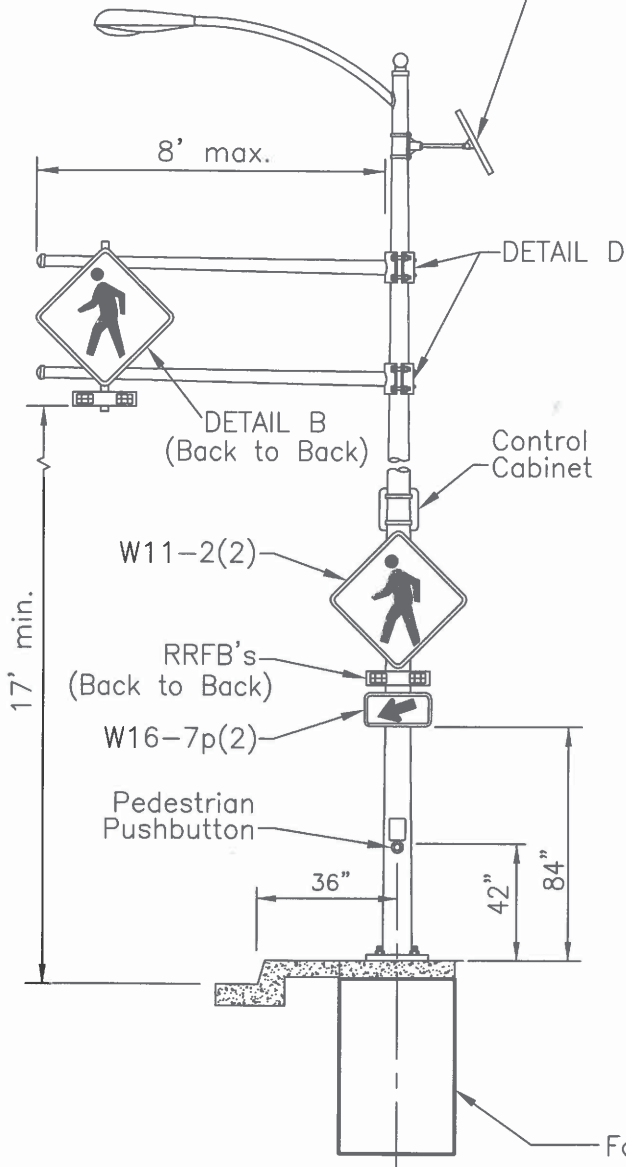

BSL POLES
(CD953A, CD953B, CD953C)

TYPICAL INSTALLATION

Not to scale

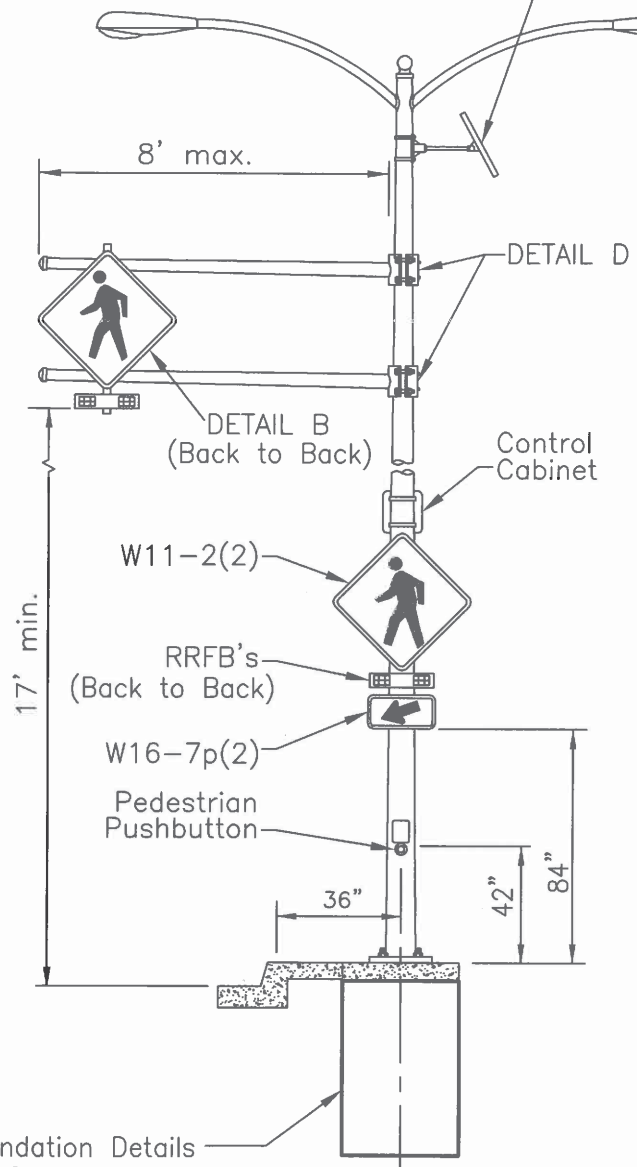

Tilt solar panel to 60° and rotate assembly so collector panel will face due south.



BSL POLES
(CD953-A2, CD953-B2, CD953-C2)

TYPICAL INSTALLATION

Not to scale

BUREAU OF ENGINEERING GARY LEE MOORE, PE, ENV SP, CITY ENGINEER	DWN	AC	01-22-20	Title BSL POLES WITH RECTANGULAR RAPID FLASHING BEACON SIGN ARM 1/4
	REV	-		
STRUCTURAL DESIGN CHECKED BY: <u>VIGEN GHARIBIAN, SE</u> APPROVED BY:  SHAILESH PATEL, SE, DIVISION ENGINEER, STRUCTURAL ENGINEERING DIVISION	T.E.	SB	09-03-20	CITY OF LOS ANGELES DEPARTMENT OF TRANSPORTATION
	Sr. T.E.	JV	09-03-20	
Approved  for Seleta J. Reynolds, General Manager	Pr. T.E.	-		Drawing No. S-52.1.7

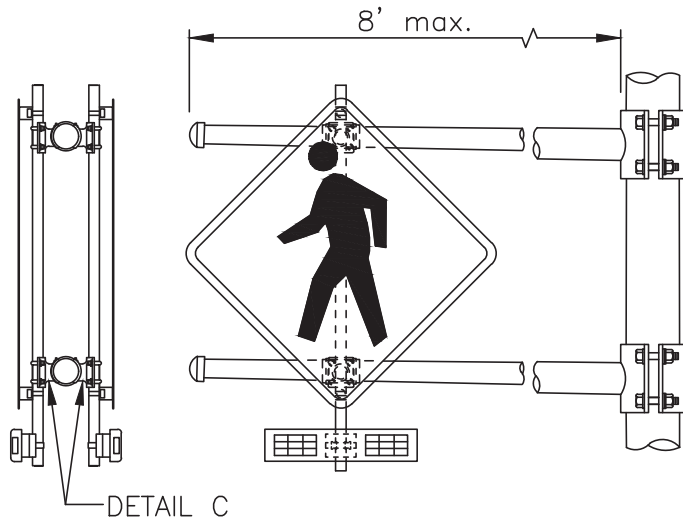

DETAIL B

Not to scale

SIGN ARM DATA				
ARM SPAN "L" (FT.)	FIXED END DIA. (IN)	FREE END DIA. (IN)	G.A.	DEGREE RISE
8'-0"	3.52	2.4	11	0.50

SIGN ARM MATERIAL DATA		
COMPONENT	ASTM DESIGNATION	MIN. YIELD (KSI)
SIGN ARM SHAFT	A595 GR. A	55
CLAMP	A572	55
SIGN ARM CONN. BOLTS	A325	55
HARDWARE COATING	HOT DIP ZINC	

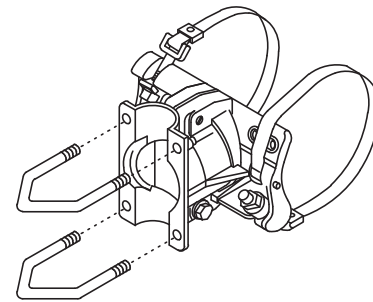

(PELCO AB-3004)

DETAIL C

Not to scale

FINISH NOTES	
SYSTEM:	GALVANIZED (GV)
BASE COAT:	HOT DIP GALVANIZED TO ASTM A123
PRIME COAT:	NONE
COLOR:	NONE
FINISH COAT:	NONE

SIGN DIMENSIONS			
SIGN DESIGNATION	SIGN OR PLAQUE	CONVENTIONAL ROAD	
		SINGLE LANE	MULTI-LANE
W11-2	PEDESTRIAN	30x30*	36x36
W16-7p	DOWNWARD DIAGONAL ARROW	24x12	24x12

* The minimum size required for diamond-shaped warning signs facing traffic on multi-lane conventional roads shall be 36x36 per MUTCD section 2C.04.

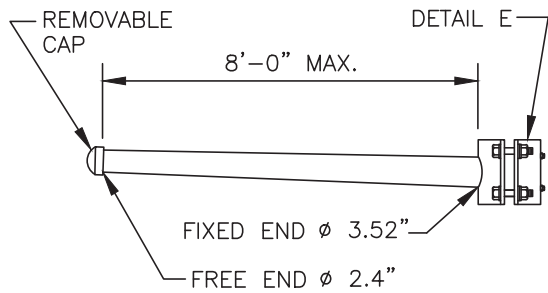

SIGN ARM ATTACHMENT

DETAIL D
Not to scale

SIGN ARM ATTACHMENT DATA	
CLAMP RANGE (DIAMETER)	A
3.75"-5.00"	7.08"
4.75"-6.00"	8.24"
5.75"-7.00"	9.36"
6.75"-8.00"	10.42"
7.75"-9.00"	11.49"
8.75"-10.00"	12.59"
9.75"-11.00"	13.64"
10.75"-12.00"	14.64"
11.75"-13.00"	15.71"
12.75"-14.00"	16.74"
13.75"-15.00"	17.77"
14.75"-16.00"	18.79"
15.75"-17.00"	19.81"

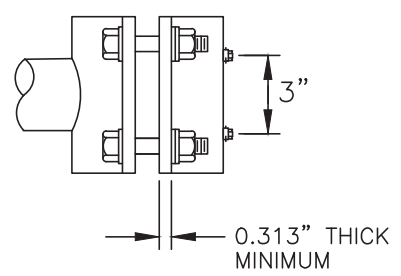
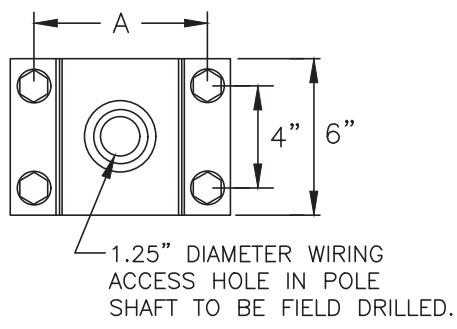
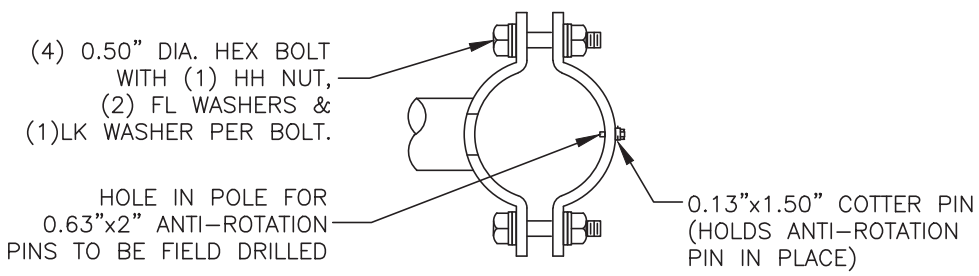

DETAIL E
Not to scale

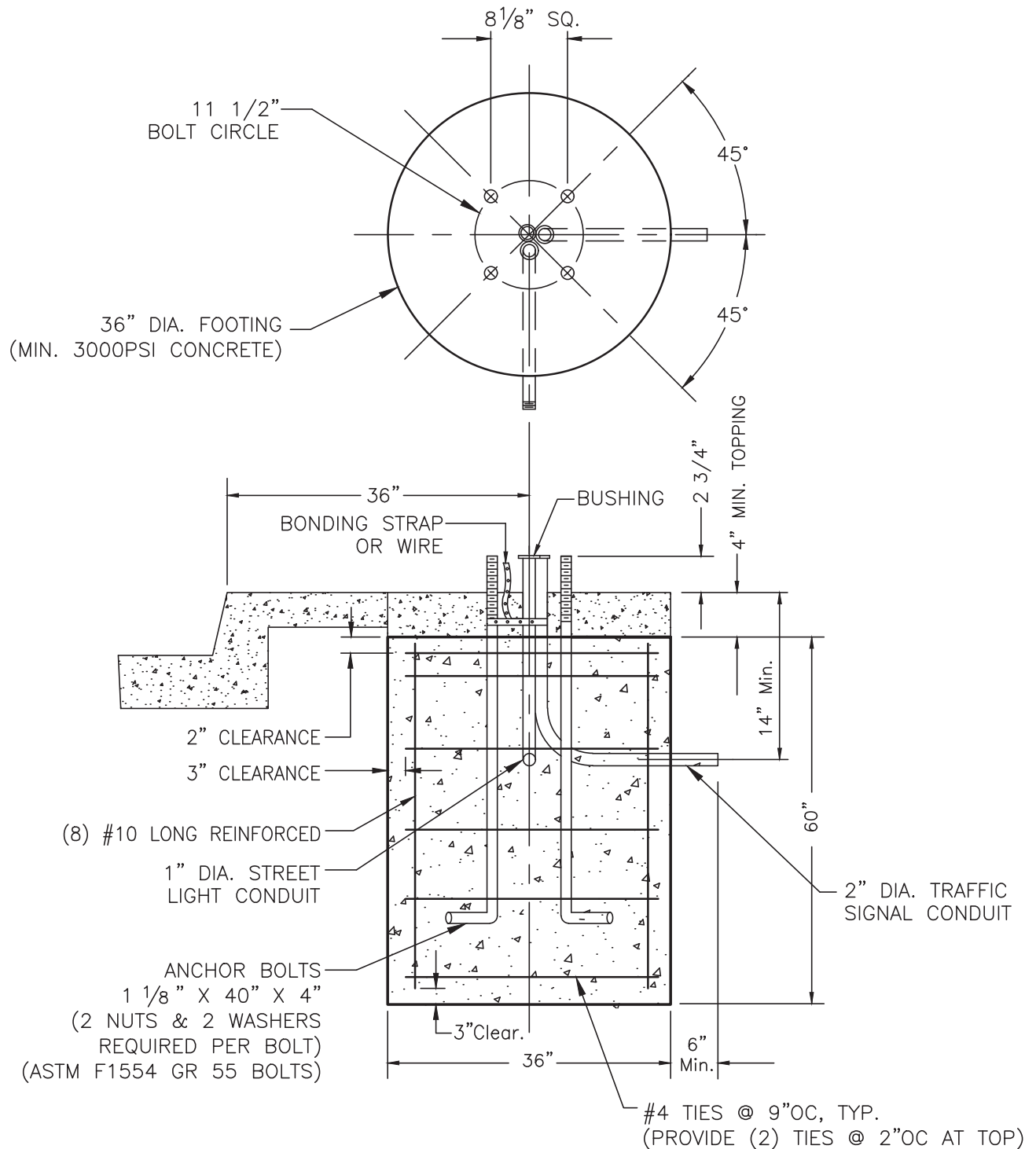

Notes:

1. Use 1" galvanized conduit for street lighting and 2" schedule 80 PVC conduit for traffic signal unless otherwise specified.
2. Conduit stubs from foundation shall be in the direction of the nearest corresponding pullbox unless otherwise specified.
3. Topping shall be considered as a part of the foundation.
4. Coordinate bolt circle with light pole base plate prior to anchor bolt installation.
5. Coordinate conduit size and placement with electrical prior to installation.

<p>CITY OF LOS ANGELES DEPARTMENT OF TRANSPORTATION</p>	<p>Title FOUNDATION DETAILS</p>	<p>Drawing No. S-52.1.7</p>	<p>4 4</p>
---	--	--	------------------------------

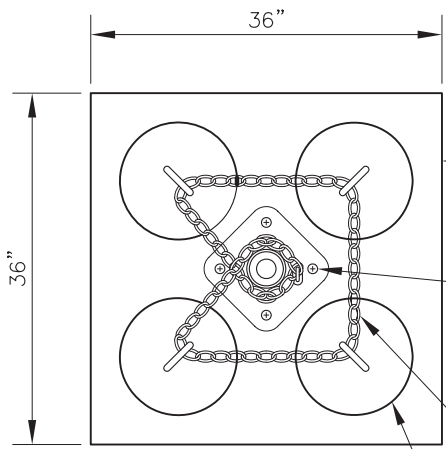

PLATFORM
(Top View Detail)
Not To Scale

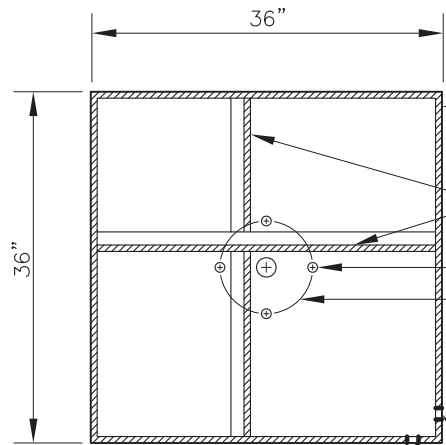

PLATFORM
(Bottom View Detail)
Not To Scale

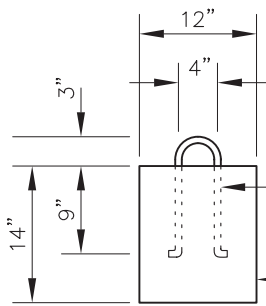

WEIGHT BLOCK
Not To Scale

USE 12" HEADS CORRESPONDING TO PERMANENT HEADS BEING REPLACED

36" SQ. x 1/4" THK. STEEL PLATFORM, HOT DIP GALVANIZED PER ASTM 123

TYPE 1 BASE W/ 4 1" DIA. x 3-1/2" BOLTS & NUTS W/ 2 WASHERS FOR EACH BOLT

3/8" DIA. STEEL COIL CHAIN TIED TO EACH 5 GAL. BLOCK AND LOCKED AROUND THE TYPE 1 STANDARD

5 GAL. CAN FILLED W/ CONCRETE. FOUR CANS ARE REQUIRED, SPACED AS SHOWN

2" HIGH x 1/4" THK. PERIMETER LIP RESTING ON GROUND

1-3/4" x 1-3/4" x 1/4" STEEL ANGLE BRACKETS WELDED TO PLATE

4 HOLES @ 1-1/4" DIA.

8-1/2" DIA. BOLT CIRCLE

1" x 1" NOTCHES FOR CABLE

5 GAL. CAN FILLED WITH CONCRETE

"LADOT" OR CONTRACTOR NAME EMBOSSED OR WELDED ON AT LEAST TWO SIDES

1/2" DIA. STEEL ROD EMBEDDED 9" DEEP

5 GAL. CAN FILLED WITH CONCRETE MIN. WEIGHT: 90 LBS.

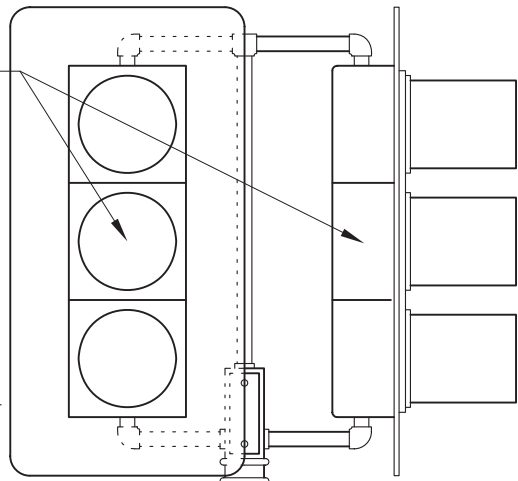

STREET NAME SIGN

3/8" DIA. STEEL COIL CHAIN TIED TO EACH 5 GAL. BLOCK AND LOCKED AROUND THE TYPE 1 STANDARD

BASE ASSEMBLY

1" x 1" NOTCH FOR CABLE

FOR SLOPES GREATER THAN 1/2" RISE PER FOOT, TEMPORARY STANDARD TO BE SET LEVEL THROUGH THE USE OF GRADING OR WOOD SHIMS

TYPE 1 STANDARD
Not To Scale

DWN	MT	3-1-16	Title TEMPORARY SIGNAL FOR TYPE 1 STANDARD	1/1
CKD				
T. E.	JV	3-3-16		
Sr. T. E.	MA	3-8-16	CITY OF LOS ANGELES DEPARTMENT OF TRANSPORTATION	
Pr. T. E.	VJ	4-8-16		
Approved			4-11-16	Drawing No.
Seleta J. Reynolds, General Manager			S-57.2B	

NOTES:

1. THE CD954 STANDARD (WITHOUT LUMINAIRE ARM) SHALL CONFORM TO DEPT. OF TRANSPORTATION, CITY OF LOS ANGELES STANDARD DWG. # S-51.9.6 (FOUNDATION EXCLUDED).
2. THE MAST ARM LENGTH SHALL NOT EXCEED 15'-0".
3. THERE SHALL BE A MAXIMUM OF 2 - 5 SECTION SIGNAL HEADS & 2 - PED. HEADS MOUNTED TO THE SHAFT AND ONE 5-SECTION SIGNAL HEAD MOUNTED AT THE END OF MAST ARM.

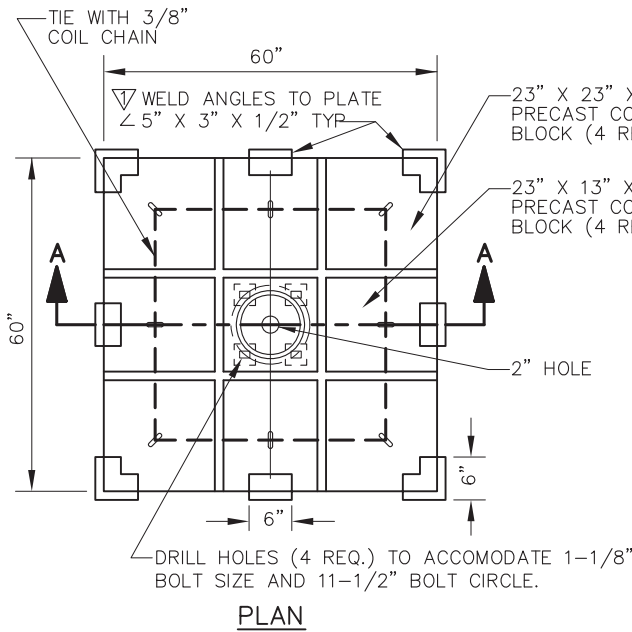

PLAN

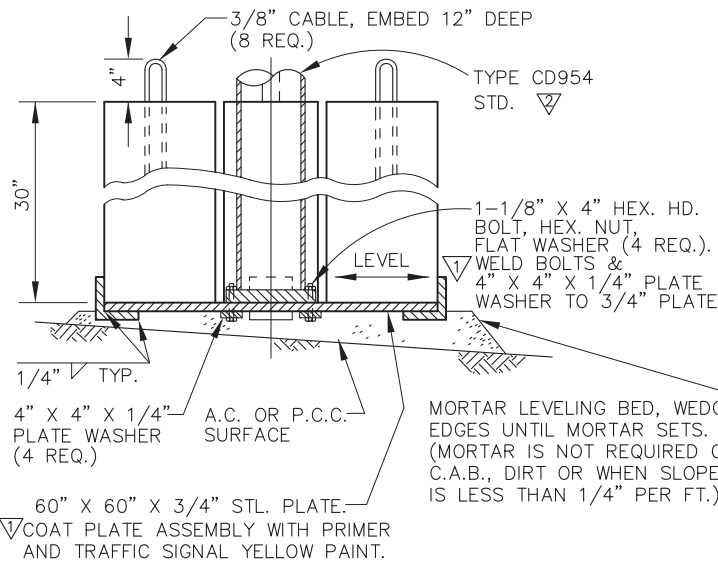

SECTION A-A

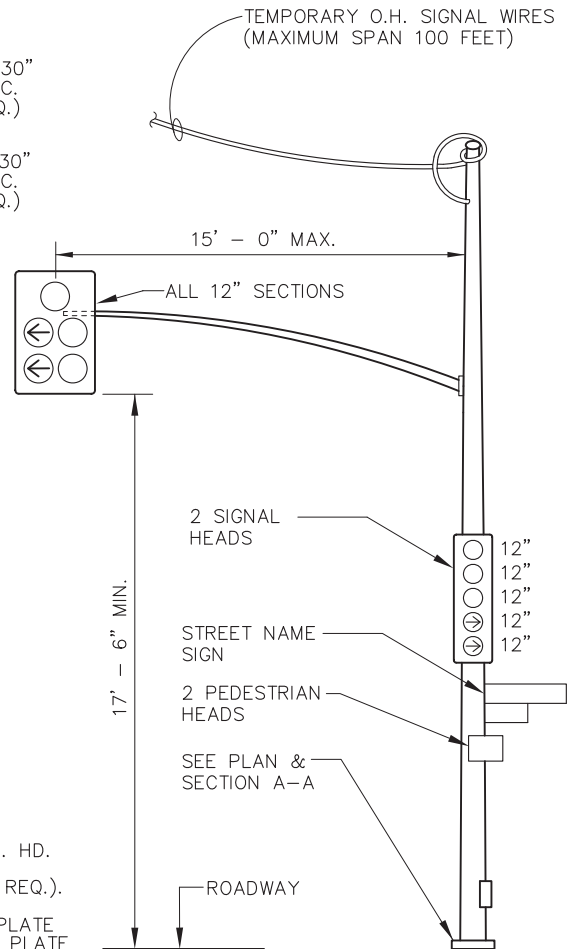

TYPE CD 954 STD. (WITHOUT LUMINAIRE ARM)

STRUCTURAL ENGINEERING DIVISION	
CHECKED FOR	STRUCTURAL DESIGN
DIV. ENGR.	P. H. Skarin
DATE	8-7-84

Drawn By	JC	6-17-84
Checked By	RO	6-21-84
Supervised By	JK	6-21-84
Reviewed By	JAC	6-26-84
Revisions		
Updated	JK	JAC 6-4-86
Updated	ERA RF	GH 11-5-91
Change Title From	CW	GH 3-27-92
Type 17 to CD 954		
Modified Primary Signal Head Dimension	GH	5-13-92
Updated Mast Arm Head Clearance & Reference to Std. dwgs		12-07-07

<p>SIGNAL, TEMPORARY FOR TYPE CD954 STD. (WITHOUT LUMINAIRE ARM)</p>	
<p>CITY OF LOS ANGELES DEPARTMENT OF TRANSPORTATION DONARD R. HOWERY, General Manager</p>	
Approved	August 8, 1984
Donald R. Howery	General Manager
DRAWING NO. S-57.2C	

NOTES:

1. THE CD954 STANDARD SHALL CONFORM TO DEPT. OF TRANSPORTATION, CITY OF LOS ANGELES, STANDARD DRAWING # S-51.9.6 (FOUNDATION EXCLUDED).
2. THE MAST ARM LENGTH SHALL NOT EXCEED 15'-0".
3. THERE SHALL BE A MAXIMUM OF 2 - 5 SECTION SIGNAL HEADS & 2 - PED. HEADS MOUNTED TO THE SHAFT AND ONE 3-SECTION SIGNAL HEAD MOUNTED AT THE END OF MAST ARM. ALL SIGNAL HEADS TO BE POLYCARBONATE TYPE.

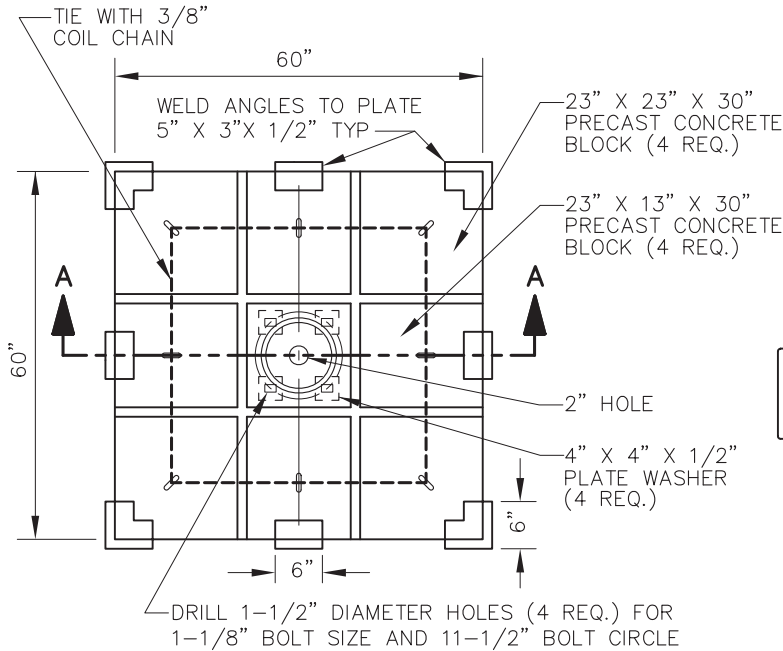

PLAN

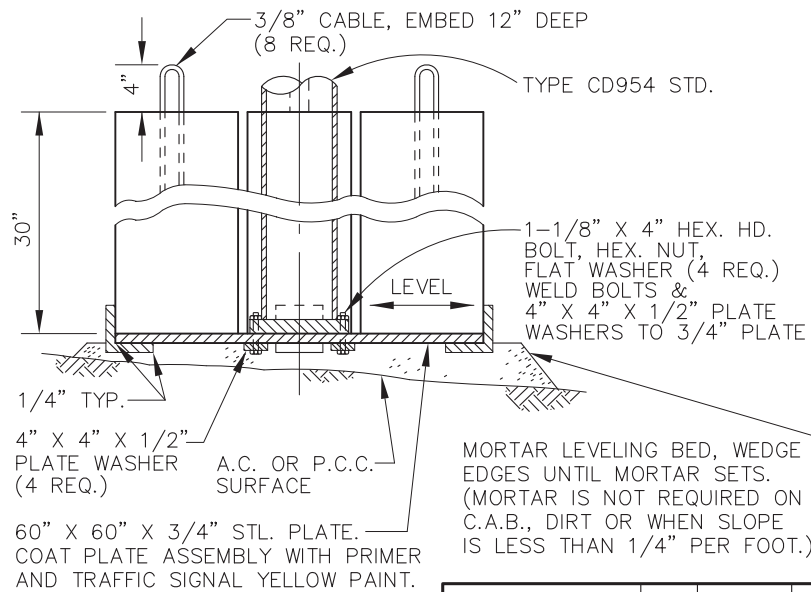

SECTION A-A

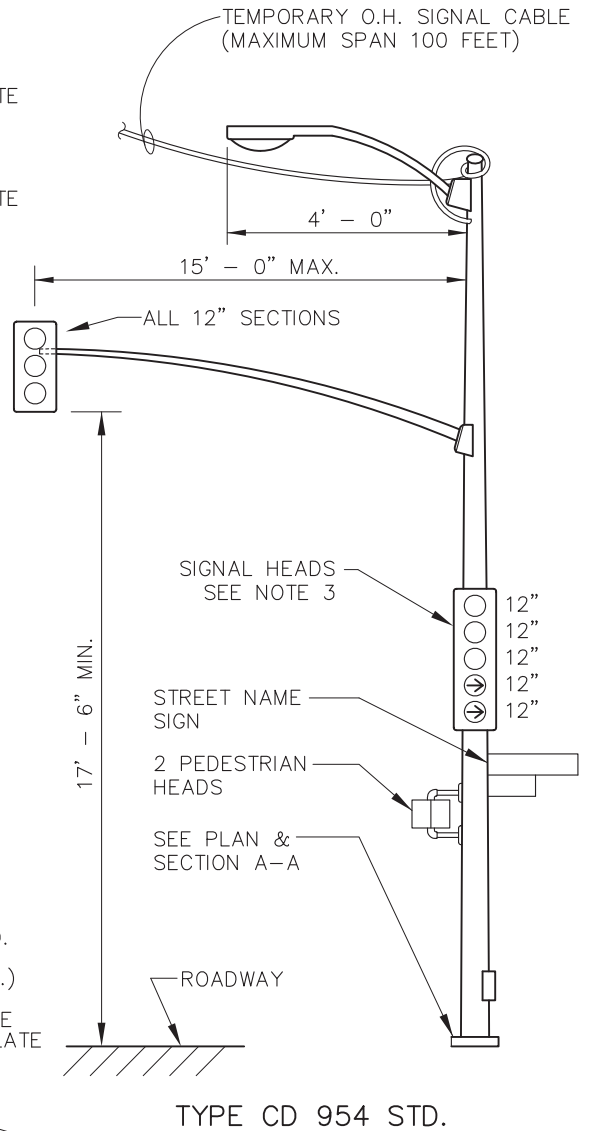

Drawn By	AC	07-30-96
Checked By	AM	07-30-96
Supervised By	AM	07-30-96
Reviewed By	KF	02-13-97

Title		
SIGNAL, TEMPORARY FOR TYPE CD954 STD.		
CITY OF LOS ANGELES DEPARTMENT OF TRANSPORTATION ROBERT R. YATES, General Manager		
Approved	2-18-97	DRAWING NO.
Robert R. Yates General Manager		S-57.2D

STRUCTURAL ENGINEERING DIVISION
CHECKED FOR STRUCTURAL DESIGN DIV. ENGR. <u>C. W. Robins</u> DATE <u>8-29-96</u>

Revisions		

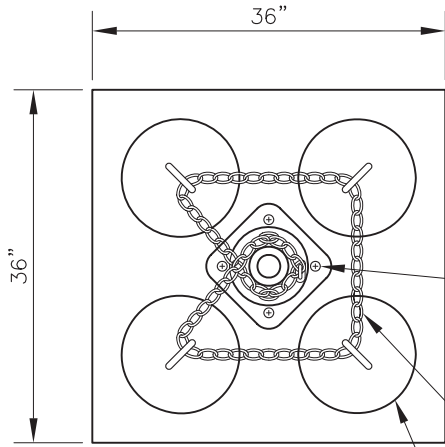

PLATFORM
(Top View Detail)
Not To Scale

36" SQ. x 1/4" THK. STEEL PLATFORM, HOT DIP GALVANIZED PER ASTM 123

TYPE 1 BASE W/ 4 1" DIA. x 3-1/2" BOLTS & NUTS W/ 2 WASHERS FOR EACH BOLT

3/8" DIA. STEEL COIL CHAIN TIED TO EACH 5 GAL. BLOCK AND LOCKED AROUND THE TYPE 1 STANDARD

5 GAL. CAN FILLED W/ CONCRETE. FOUR CANS ARE REQUIRED, SPACED AS SHOWN

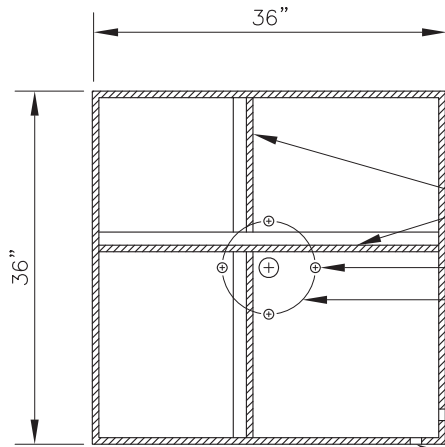

PLATFORM
(Bottom View Detail)
Not To Scale

2" HIGH x 1/4" THK. PERIMETER LIP RESTING ON GROUND

1-3/4" x 1-3/4" x 1/4" STEEL ANGLE BRACKETS WELDED TO PLATE

4 HOLES @ 1-1/4" DIA. 8-1/2" DIA. BOLT CIRCLE

1" x 1" NOTCHES FOR CABLE

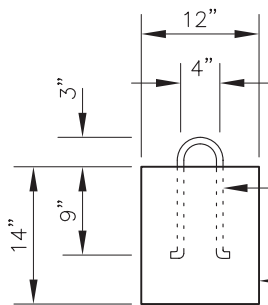

WEIGHT BLOCK
Not To Scale

"LADOT" OR CONTRACTOR NAME EMBOSSED OR WELDED ON AT LEAST TWO SIDES

1/2" DIA. STEEL ROD EMBEDDED 9" DEEP

5 GAL. CAN FILLED WITH CONCRETE MIN. WEIGHT: 90 LBS.

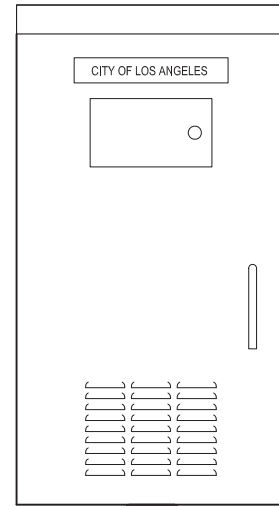

337 CABINET



3/8" DIA. STEEL COIL CHAIN TIED TO EACH 5 GAL. BLOCK AND LOCKED AROUND THE TYPE 8 STANDARD

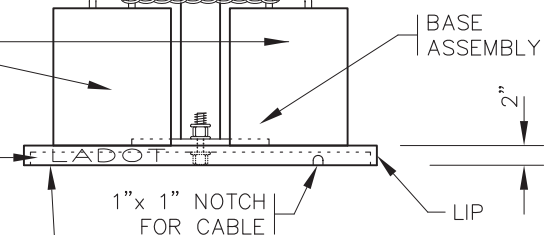

BASE ASSEMBLY

5 GAL. CAN FILLED WITH CONCRETE

1" x 1" NOTCH FOR CABLE

LIP

FOR SLOPES GREATER THAN 1/2" RISE PER FOOT, TEMPORARY STANDARD TO BE SET LEVEL THROUGH THE USE OF GRADING OR WOOD SHIMS

TYPE 8 STANDARD
Not To Scale

DWN	MT	3-1-16	Title TEMPORARY CONTROLLER FOR TYPE 8 STANDARD (1/1)
CKD			
T. E.	JV	3-3-16	
Sr. T. E.	MA	3-8-16	CITY OF LOS ANGELES DEPARTMENT OF TRANSPORTATION
Pr. T. E.	VJ	4-11-16	
Approved		4-11-16	Drawing No.
 Seleta J. Reynolds, General Manager		S-57.3	

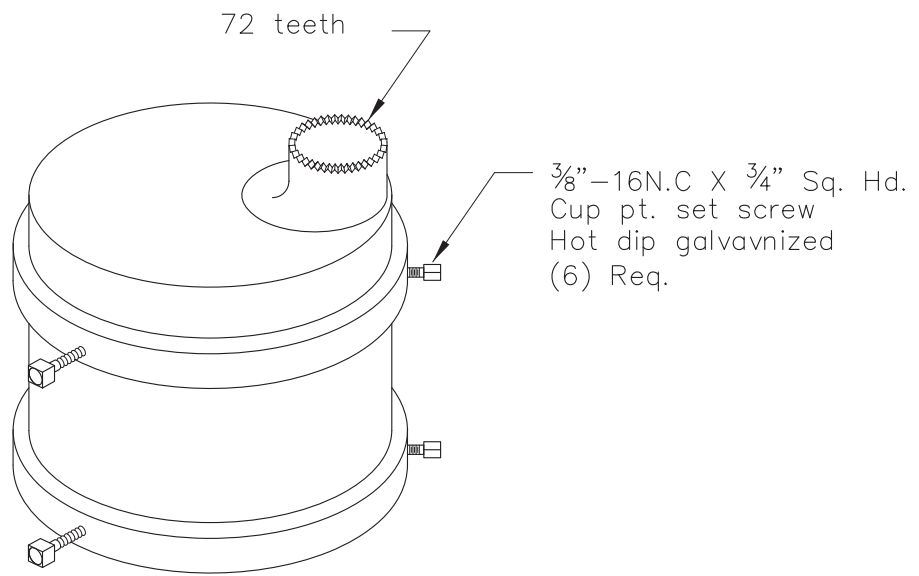

Slip Fitter

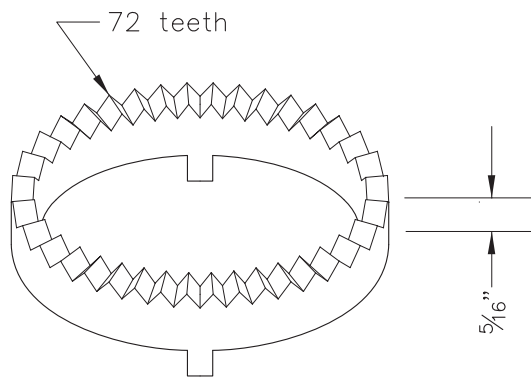

Lock Ring

Note:

1. Construction, material & finish painting shall conform to "Standard Specifications", (latest edition), Dept. of Transportation, State of California.

Drawn By	RAL	2-67	Title FITTINGS, TYPICAL, POST TOP MOUNTING
Checked By			
Supervised By			
Reviewed By			
Revisions			CITY OF LOS ANGELES DEPARTMENT OF TRANSPORTATION Donald R. Howery, General Manager
Updated	RO	JF 3-14-83	
			Approved <u>Apr 5, 1967</u>
			A. L. Hutchison Asst. General Manager
			DRAWING NO. S-61.1

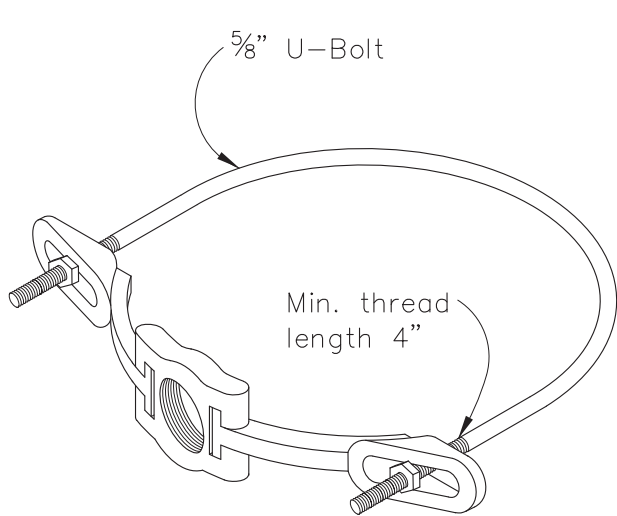

Pole Clamp

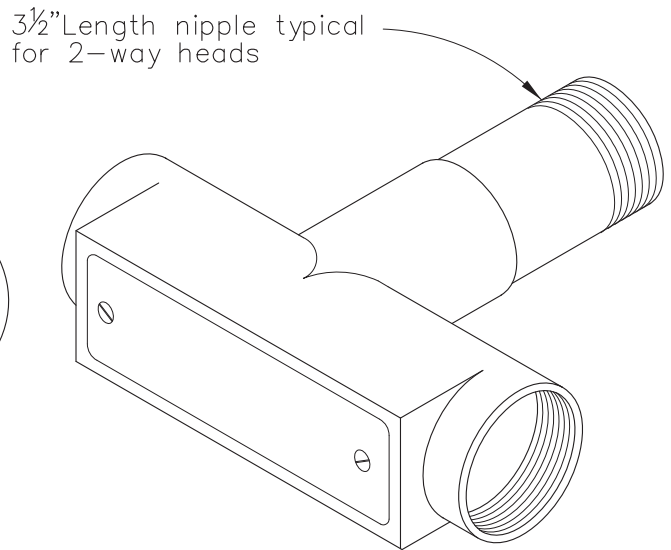

"Condulet" - TB

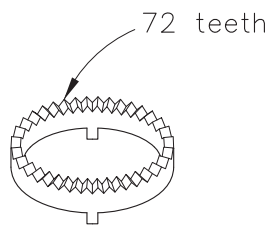

Lock Ring

Note:

1. Construction, material & finish painting shall conform to "Standard Specifications", (latest edition), Dept. of Transportation, State of California.

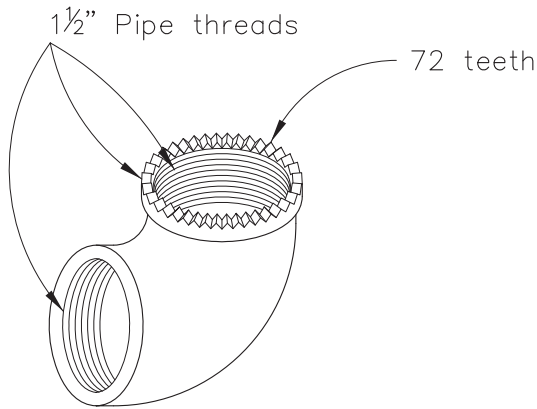

Special 90° Elbow

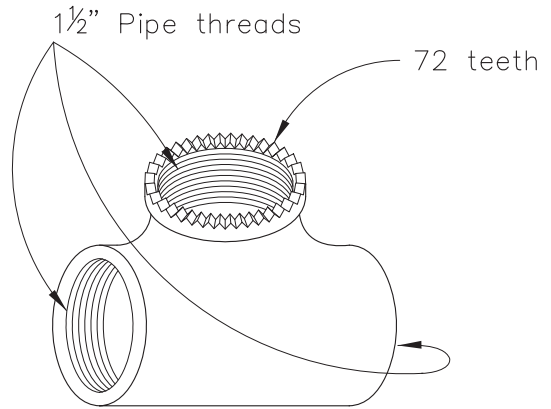

Special Tee

Drawn By	RAL	2-67	Title	FITTINGS, TYPICAL, CLAMP MOUNTING
Checked By				
Supervised By				
Reviewed By				
Revisions				
Updated	RO	JF	3-14-83	
			Approved	Apr 5, 1967
			A. L. Hutchison	DRAWING NO.
			Asst. General Manager	S-62.1

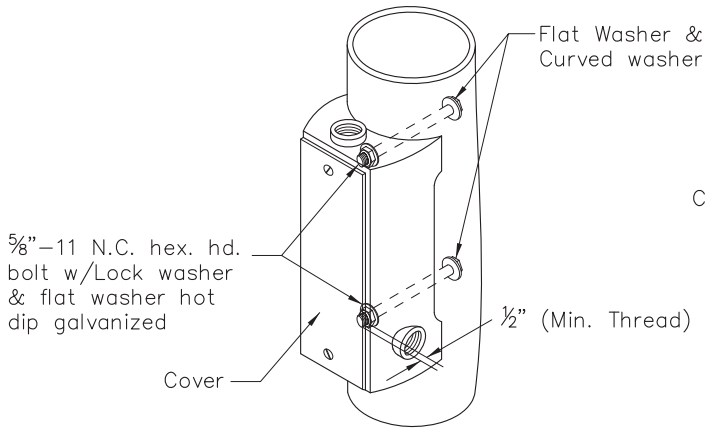

Terminal Compartment Side-Mount

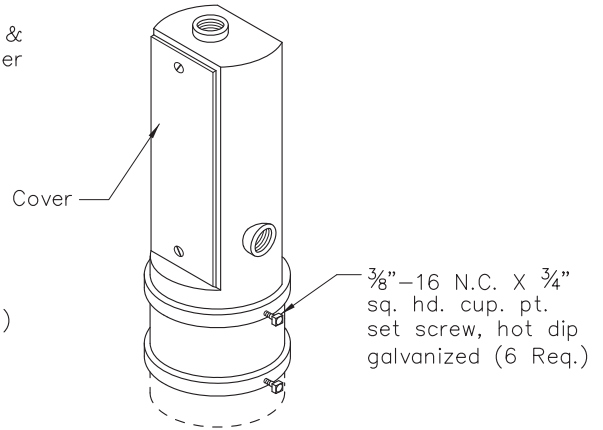

Terminal Compartment Post-Top Mount

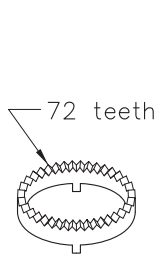

Lock Ring

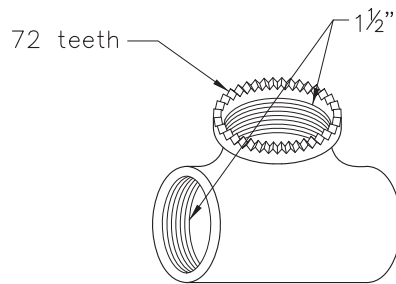

Special Tee

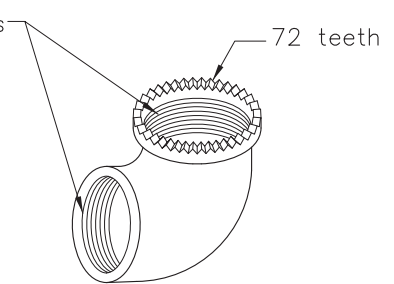

Special 90° Elbow

Washer curved to fit standard

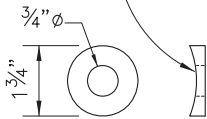

Washer Detail "A"

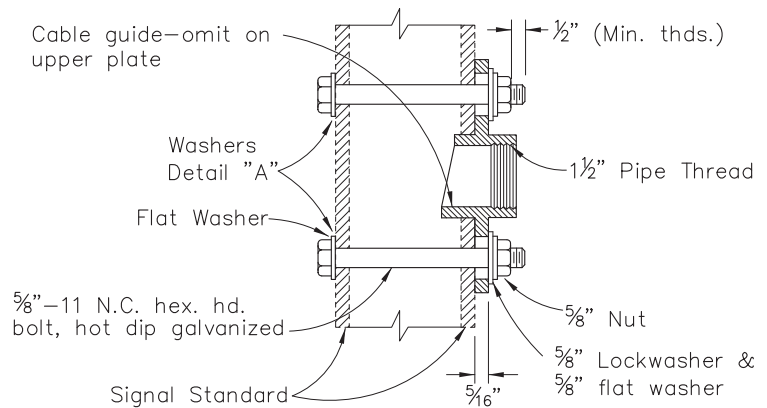

Pole Plate
For Side Mountings

Note:

1. Construction, material & finish painting shall conform to "Standard Specifications" (latest edition), Dept. of Transportation, State of California.

DWN	MT	11-02-11	Title Fittings, Typical, Terminal Compartment & Pole Plate Mounting
CKD			
T. E.			
Sr. T. E.			
Pr. T. E.	SS	12-8-11	CITY OF LOS ANGELES DEPARTMENT OF TRANSPORTATION
Approved	<i>John E. Fisher</i> 12-8-11		
for <u>Jaime de la Vega, General Manager</u>			S-63.1

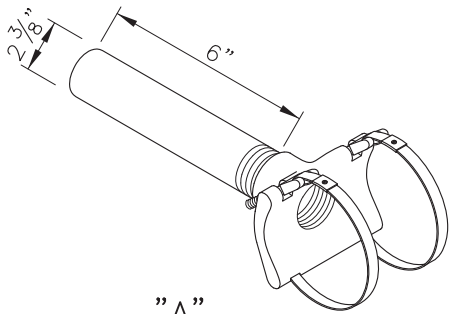

"A"
(PELCO AB-3008)

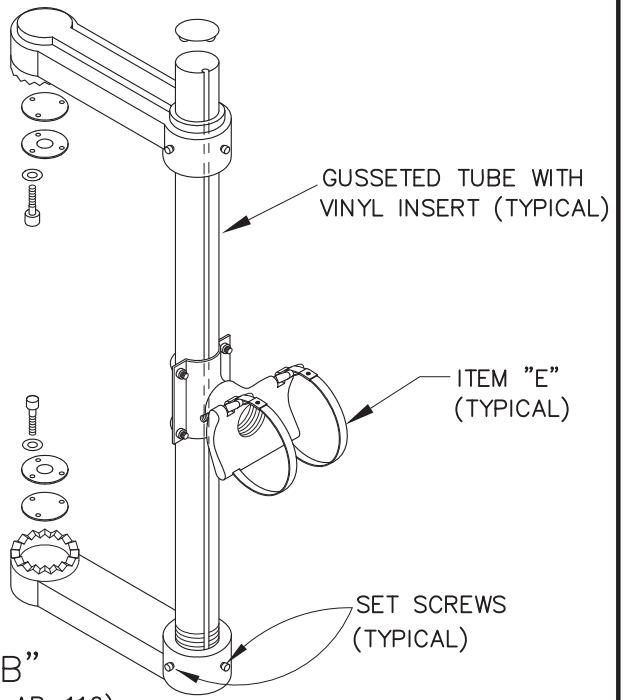

"B"
(PELCO AB-116)

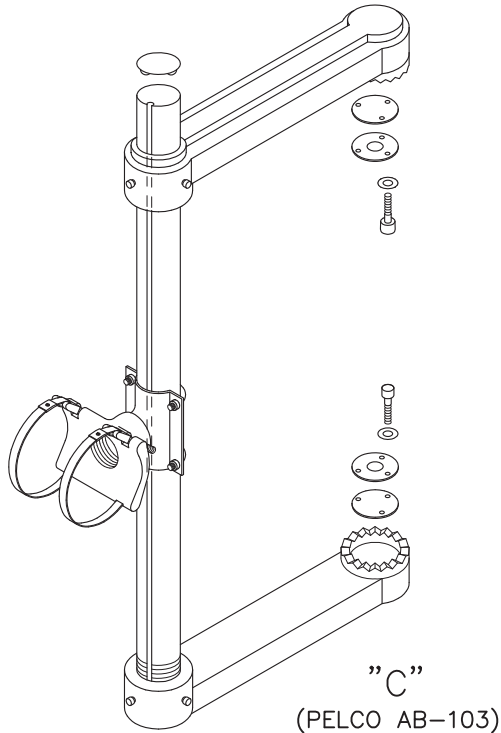

"C"
(PELCO AB-103)

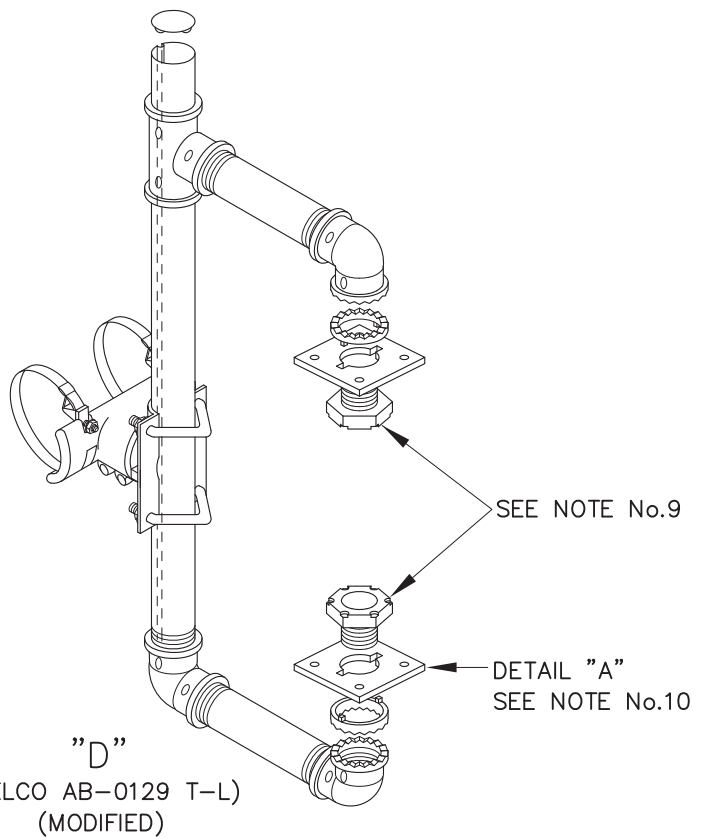

"D"
(PELCO AB-0129 T-L)
(MODIFIED)

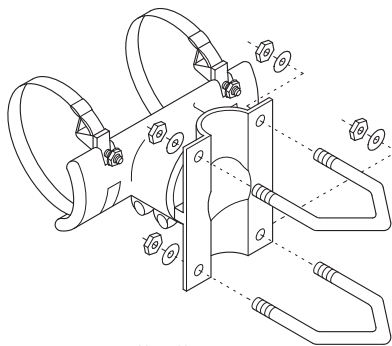

"E"
(PELCO AB-3004)

Drawn By	AC	5-12-98
Checked By	AM	5-12-98
Supervised By	AM	5-12-98
Construction By	AN	5-22-98
R e v i s i o n s		

Title		
SPECIAL MAST ARM MOUNTINGS		
CITY OF LOS ANGELES DEPARTMENT OF TRANSPORTATION THOMAS K. CONNER, General Manager		
Approved	MAY 27, 1998	DRAWING NO.
Thomas Conner General Manager		S-63.1.4

NOTES:

1. ITEM "A" IS THE BASIC MOUNTING DESIGN FOR MOST MAST ARM SIGNAL INSTALLATIONS WHEN STANDARD TENON LOCATION ON THE MAST ARM CANNOT BE UTILIZED. IT USES A 6" TENON LENGTH WITH 2 3/8" OUTSIDE DIAMETER FOR PLUMBIZER MOUNTING.
2. ITEM "B" IS USED FOR INSTALLATION OF TRAFFIC SIGNAL HEADS, EXCEPT PROGRAMMED VISIBILITY (P.V.) HEADS, WHEN IT IS DESIRED TO MOUNT THEM HORIZONTALLY OR TO ADJUST THE HEIGHT VERTICALLY BY MOVEMENT OF ITEM "E".
3. ITEM "C" IS USED FOR INSTALLATION OF HORIZONTAL OR VERTICAL PROGRAMMED VISIBILITY (P.V.) HEADS. IT IS EQUIPPED WITH 14" ARMS WHICH ALLOW FOR REPLACEMENT OF SIGNAL LAMPS LOCATED IN THE REAR OF THE SIGNAL HEAD.
4. ITEM "D" IS USED FOR INSTALLATION OF ELECTRIC SIGNS.
5. ITEM "E" IS A STANDARD CLAMP KIT DESIGNED TO BE USED FOR FASTENING ITEMS "B", "C", AND "D" TO MAST ARMS OR POLES IN A VERTICAL OR HORIZONTAL POSITION.
6. THE BOTTOM ARMS IN ITEMS "B", "C", AND "D" ARE STATIONARY AND ARE HELD IN PLACE WITH PIPE THREADS AND SET SCREWS. THE UPPER ARMS SLIDE ALONG THE SHAFT AND ARE HELD IN PLACE WITH SET SCREWS.
7. THE STANDARD 29" BAND FOR ITEM "A" AND "E" FITS A 4" TO 8.6" DIAMETER. BAND LENGTHS UP TO 56" CAN BE USED FOR LARGER DIAMETER INSTALLATIONS.
8. ITEMS "A" THROUGH "E" ARE AVAILABLE FROM PELCO PRODUCTS INC. OR EQUIVALENT.
9. THE 1 1/2"X 1 1/2" ALUMINUM LOCK NUT SHOWN WITH ITEM "D" IS COMMONLY USED FOR SIGNAL HEAD & PEDESTRIAN HEAD INSTALLATIONS.
10. THE 4 1/2"X 4 1/2"X 1/4" ALUMINUM PLATE IS USED FOR SIGN BOX REINFORCEMENT AT BRACKET INSTALLATION LOCATION AND MUST BE SPECIALLY FABRICATED.

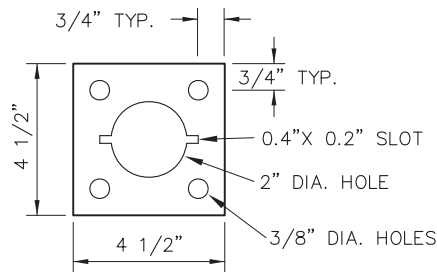

DETAIL "A"

4 1/2" X 4 1/2" X 1/4"
ALUMINUM PLATE
 NOT TO SCALE

Drawn By	AC	5-7-98	Title SPECIAL MAST ARM MOUNTINGS	
Checked By	AM	5-7-98		
Supervised By	AM	5-7-98		
Construction By	AN	5-22-98		
Revisions			CITY OF LOS ANGELES DEPARTMENT OF TRANSPORTATION THOMAS K. CONNER, General Manager	
			Approved <u>MAY 27, 1998</u>	DRAWING NO.
			Thomas Conner General Manager	S-63.1.4

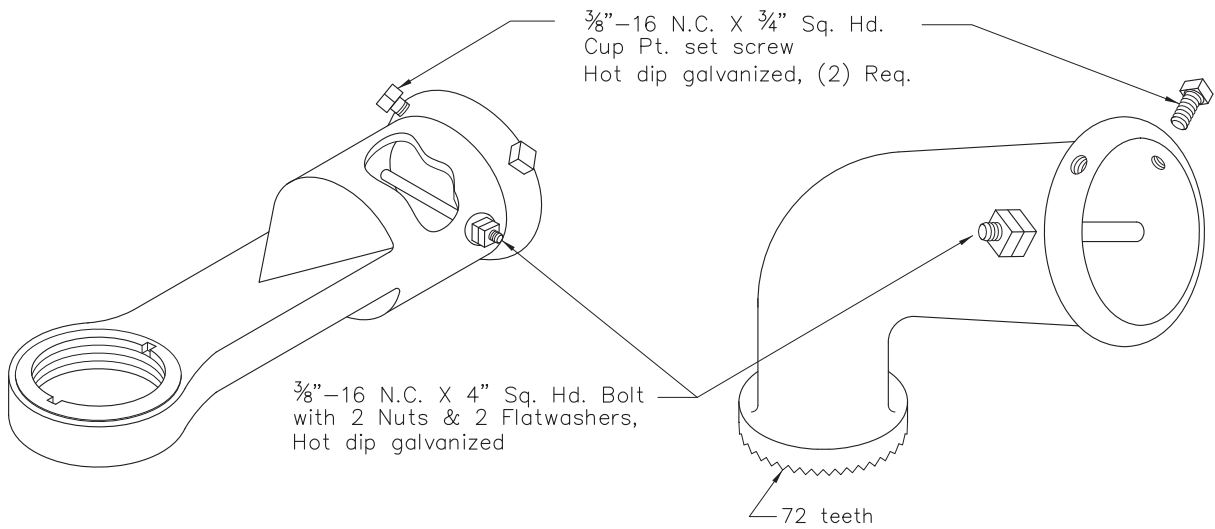

Plumbizer

Slip Fitter

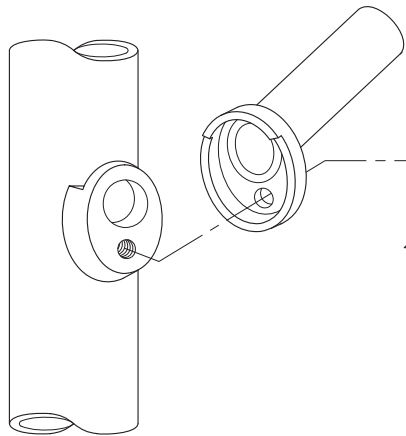

Typical Raintight Connector

Special screw
 $\frac{1}{2}$ "-13NC X $\frac{3}{4}$ "
 Modified Hex. Head.
 Hot dip galvanized

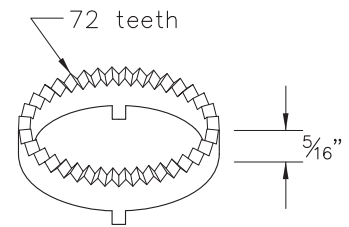

Lock Ring

Note:

1. Construction, material & finish painting shall conform to "Standard Specifications", (latest edition), Dept. of Transportation, State of California.

Drawn By	RA	2-67	Title	Fittings, Mast Arm Mounting CITY OF LOS ANGELES DEPARTMENT OF TRANSPORTATION Donald R. Howery, General Manager
Checked By				
Supervised By				
Reviewed By				
Revisions				
Updated	RO	JF 3-14-83	Approved	April 5, 1967 A. L. Hutchison Asst. General Manager
			DRAWING NO.	S-67.1

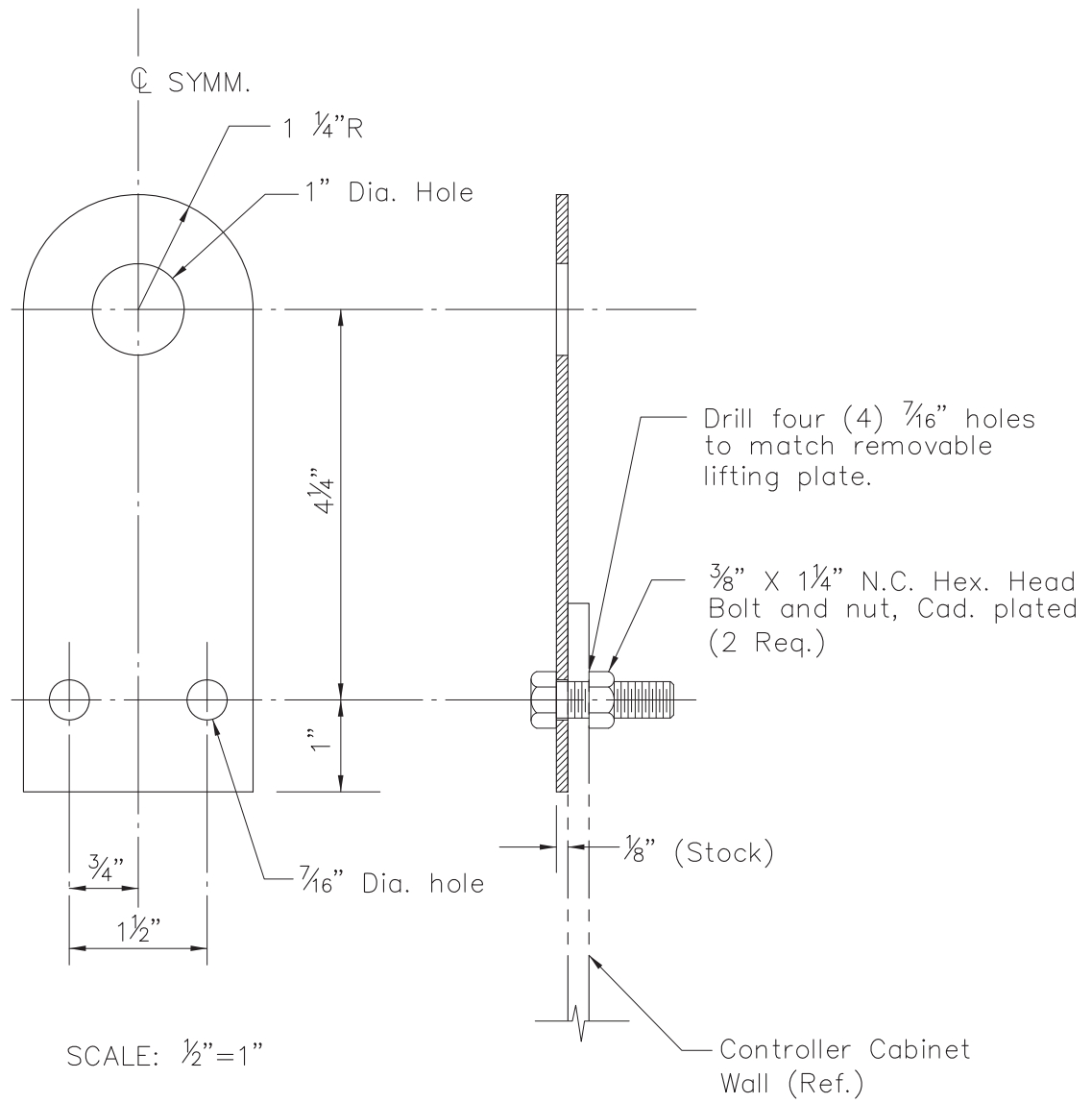

Notes:

1. Material : ASTM A36 steel plate.
2. Hot dip galvanized plate per ASTM Spec. A-123.

Drawn By	BTS	9-27-83	Title	Removable Lifting Plate for Controller Cabinets
Checked By	SB	10-3-83		
Supervised By	RO	10-3-83		
Reviewed By	JAC	10-3-83		
R e v i s i o n s			CITY OF LOS ANGELES DEPARTMENT OF TRANSPORTATION Donald R. Howery, General Manager	
Updated	RO		Approved	Oct. 3, 1983
			Donald R. Howery	DRAWING NO.
			General Manager	S-68.1

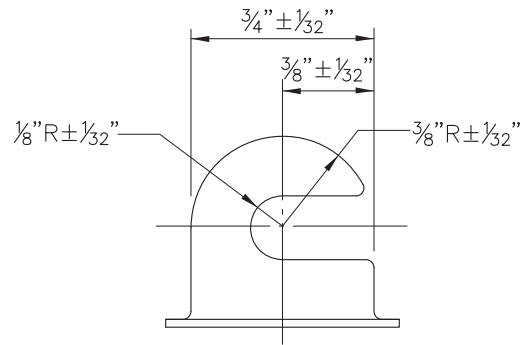
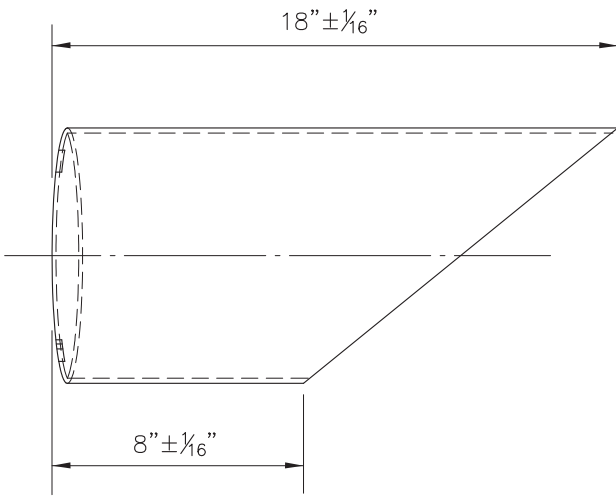

Ear Detail

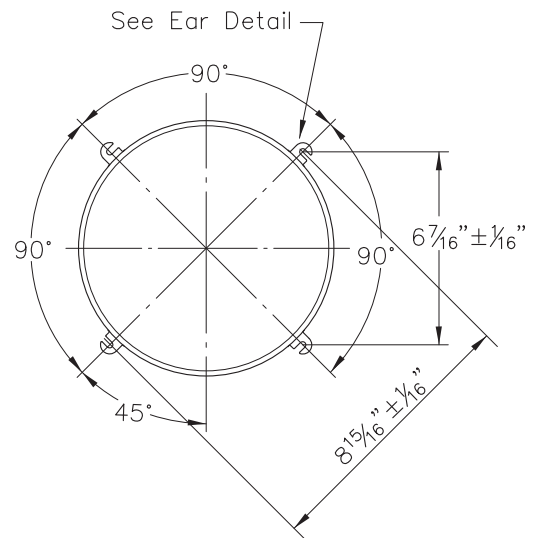
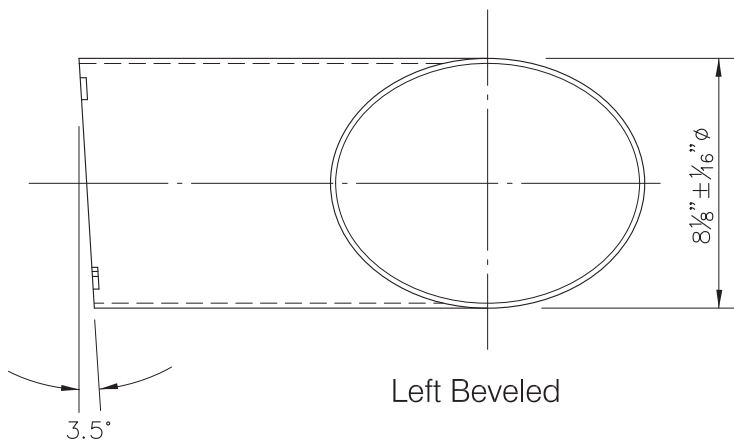

Note:

Bevel opposite side for Right Beveled Visor. Refer to LADOT Purchase Specification # 92-061-06 for all other details.

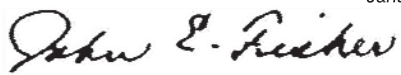
DWN	MT	1-04-11	Title
CKD	RSM	1-26-11	
T. E.			CITY OF LOS ANGELES DEPARTMENT OF TRANSPORTATION
Sr. T. E.			
Pr. T. E.			
Approved			January 26, 2011
 for Amir Sedadi, Interim General Manager			Drawing No.
			S-76.3

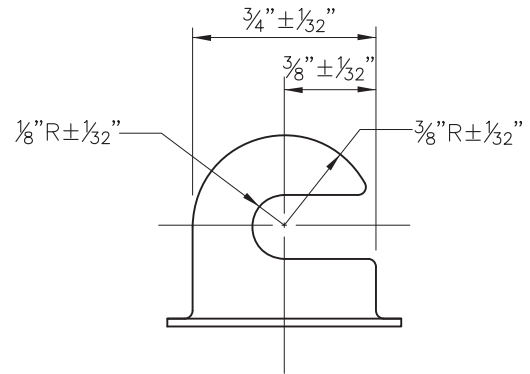
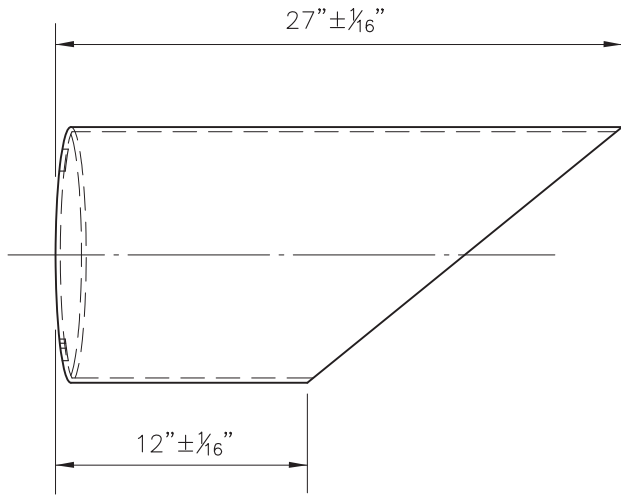

Ear Detail

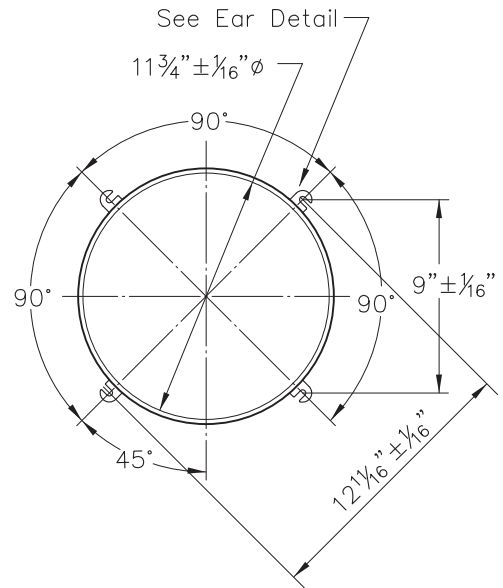
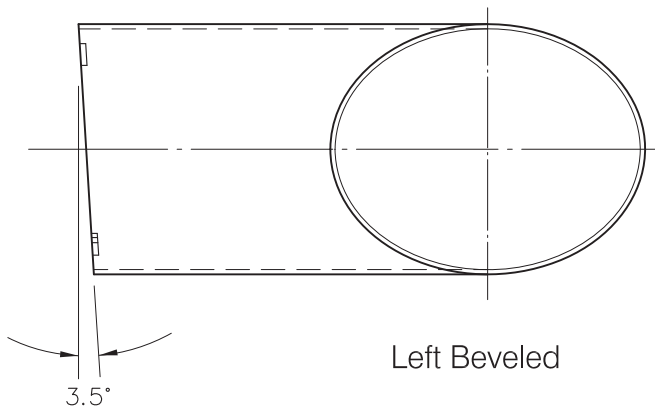

Note:

Bevel opposite side for Right Beveled Visor. Refer to LADOT Purchase Specification # 92-061-06 for all other details.

DWN	MT	1-05-11	Title
CKD	RSM	1-26-11	
T. E.			VISOR, 12" DIA., BEVELED CITY OF LOS ANGELES DEPARTMENT OF TRANSPORTATION
Sr. T. E.			
Pr. T. E.			
Approved	<i>John E. Fisher</i> for Amir Sedadi, Interim General Manager		

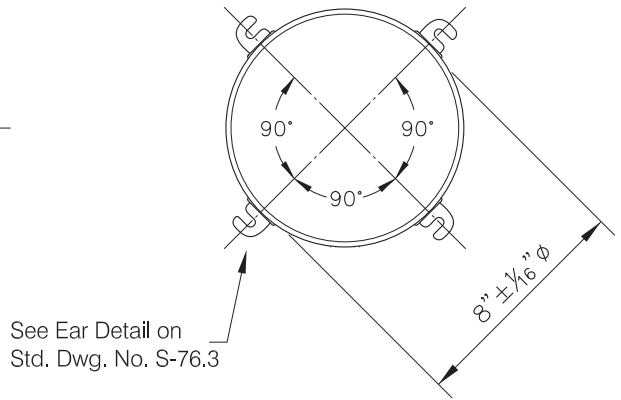
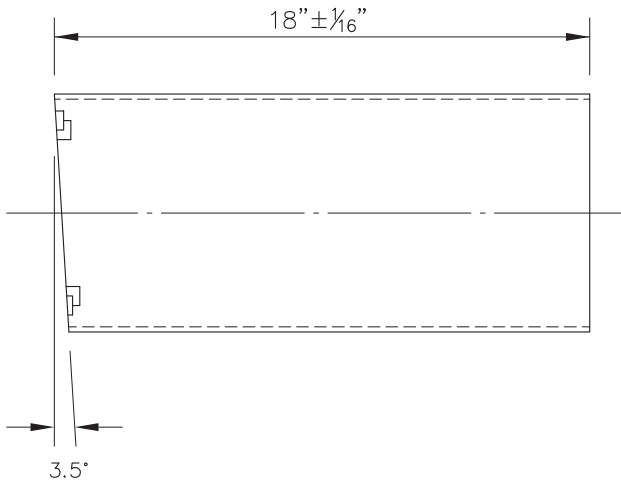

See Ear Detail on
Std. Dwg. No. S-76.3

Long Visor, 8" X 18" full circle
Not to Scale

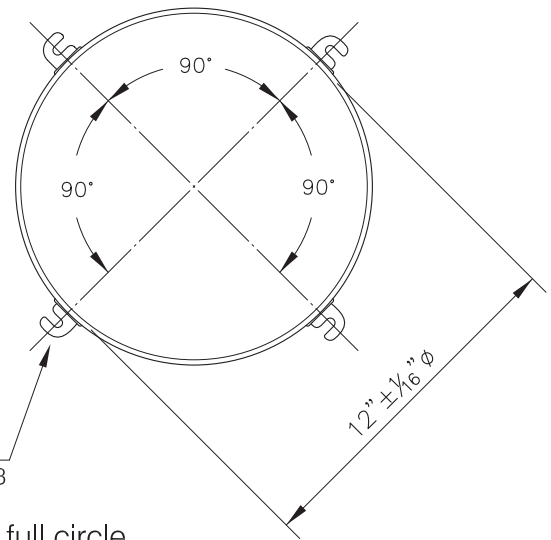
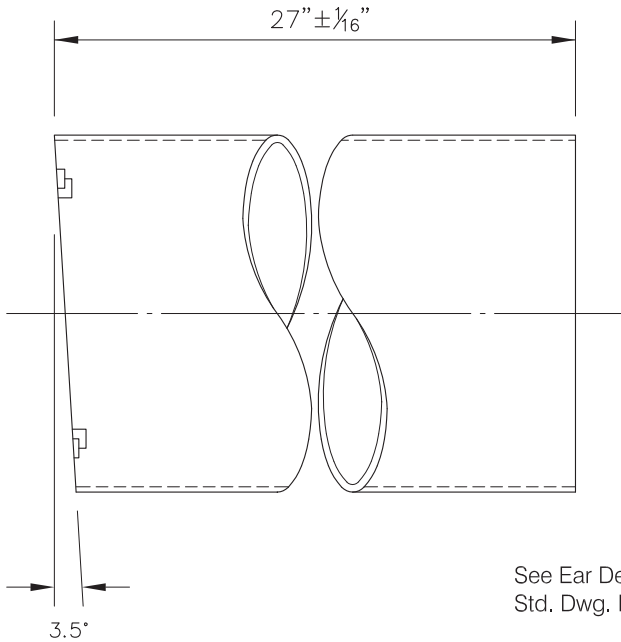

See Ear Detail on
Std. Dwg. No. S-76.3

Long Visor, 12" X 27" full circle
Not to Scale

Note:

Refer to LADOT Purchase Specification # 92-061-06 for all other details.

DWN	MT	1-05-11	Title LONG VISOR 8" & 12" DIAMETER FULL CIRCLE
CKD	RSM	1-26-11	
T. E.			
Sr. T. E.			CITY OF LOS ANGELES DEPARTMENT OF TRANSPORTATION
Pr. T. E.			
Approved		<i>John E. Fisher</i>	January 26, 2011
		for Amir Sedadi, Interim General Manager	Drawing No. S-76.7

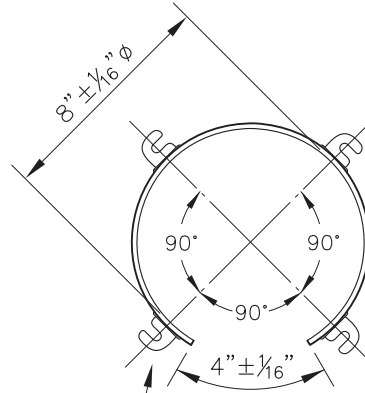
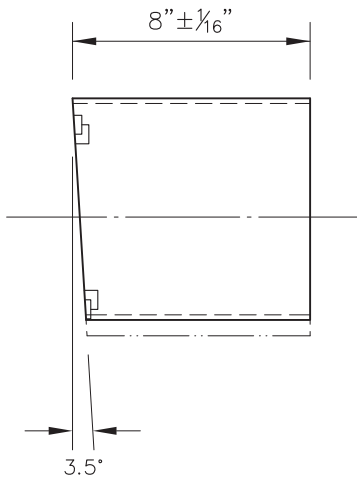

See Ear Detail on
Std. Dwg. No. S-76.3

Visor, 8" X 8" Tunnel
Not to Scale

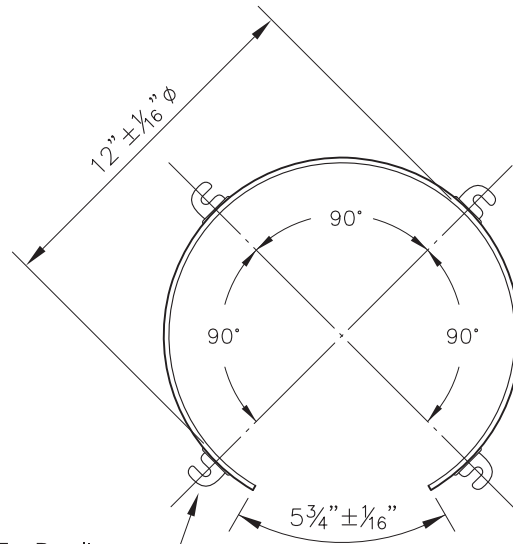
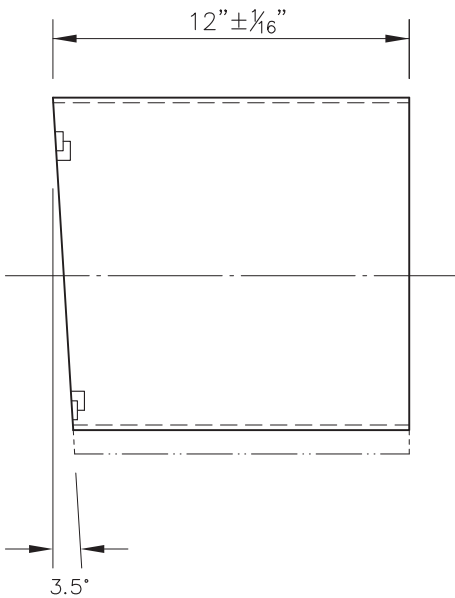

See Ear Detail on
Std. Dwg. No. S-76.3

Visor, 12" X 12" Tunnel
Not to Scale

Note:

Refer to LADOT Purchase Specification # 92-061-06 for all other details.

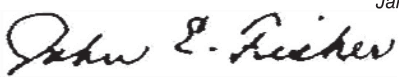
DWN	MT	1-05-11	Title PIGEON (TUNNEL) VISOR 8" & 12" DIAMETER
CKD	RSM	1-26-11	
T. E.			
Sr. T. E.			CITY OF LOS ANGELES DEPARTMENT OF TRANSPORTATION
Pr. T. E.			
Approved		January 26, 2011	Drawing No.
 for Amir Sedadi, Interim General Manager			S-76.8

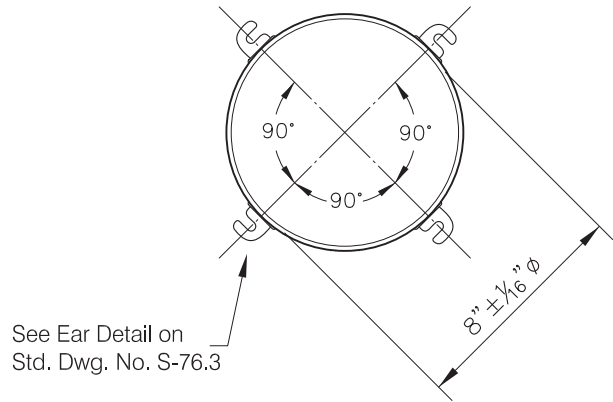
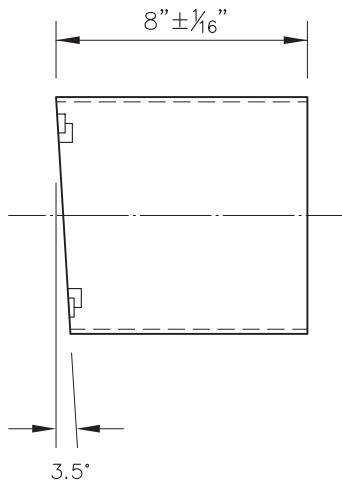

Visor, 8" full circle
Not to Scale

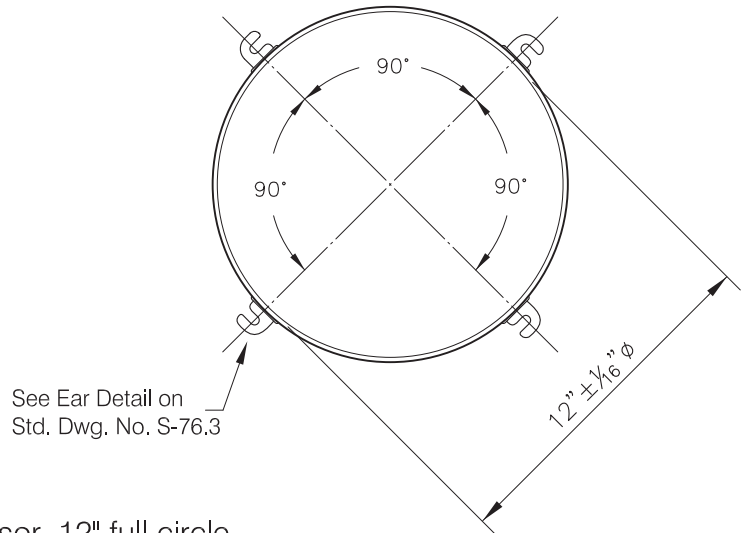
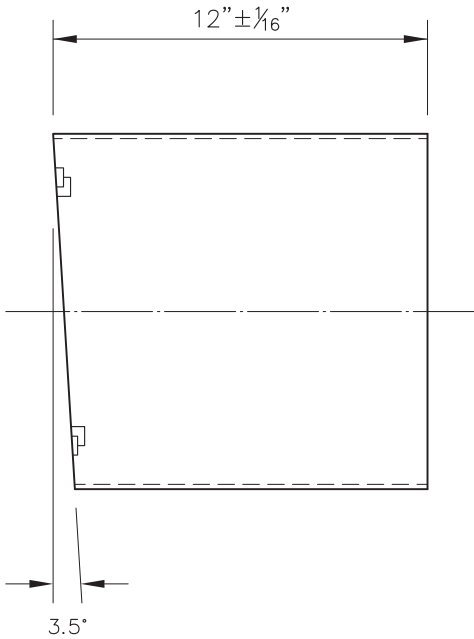

Visor, 12" full circle
Not to Scale

Note:

Refer to LADOT Purchase Specification # 92-061-06 for all other details.

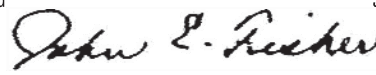
DWN	MT	1-05-11	Title VISOR 8" & 12" DIAMETER FULL CIRCLE
CKD	RSM	1-26-11	
T. E.			
Sr. T. E.			CITY OF LOS ANGELES DEPARTMENT OF TRANSPORTATION
Pr. T. E.			
Approved		January 26, 2011	Drawing No.
for 		Amir Sedadi, Interim General Manager	S-76.9

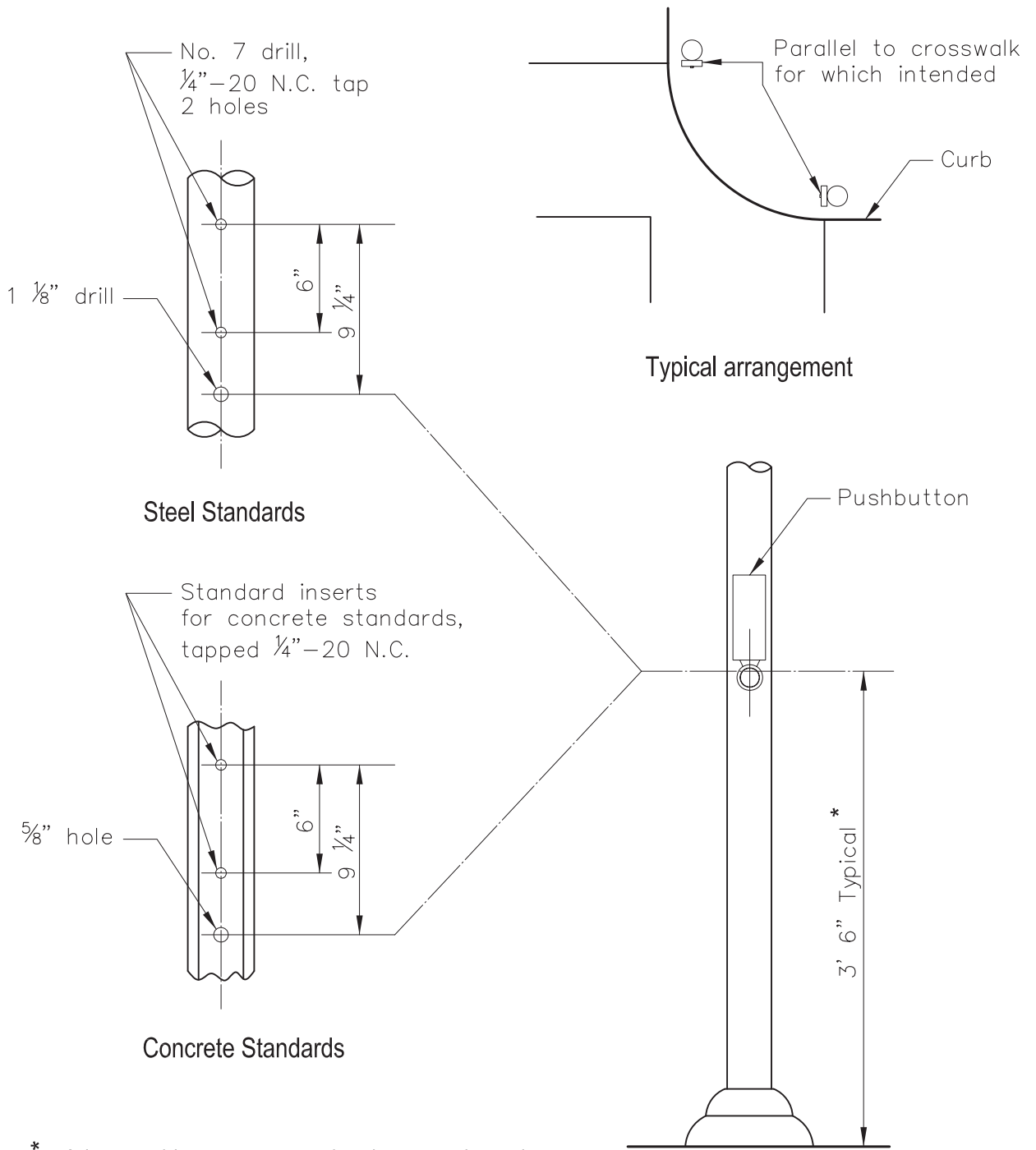

* Adjust pushbutton mounting height to 42" above the surface pedestrians are expected to access pushbutton from.

DWN	MT	9-14-11	Title
CKD			PUSHBUTTON, INSTALLATION 1/1
T. E.			
Sr. T. E.			
Pr. T. E.			
Approved		10-28-11	Drawing No.
 for Jaime de la Vega, General Manager			S-72.0A

Back of casting shaped to fit 2 1/2" dia. standard

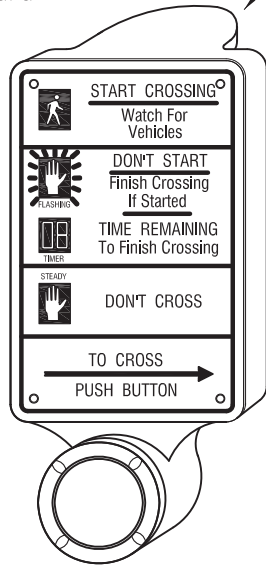

POST-TOP MOUNTING
(See S-51.7 for installation)

Back of casting shaped to fit curvature of standard

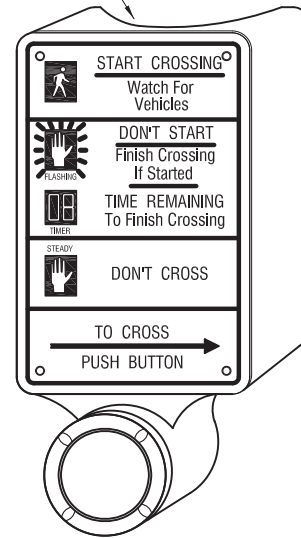

SIDE MOUNTING
(See S-72.0A for installation)

SIGN

1. Pedestrian pushbuttons – see Standard Drawings S-73.0 and S-73.1.
Bicycle pushbuttons – see Standard Drawings S-72.2.
2. Mounting hardware consists of four(4) 8-32 x 3/4" long.

HOUSING

Construction, materials and finish painting shall conform to LADOT material specification 92-052-02 or latest version.

ASSEMBLY

Construction, materials and finish painting shall conform to LADOT material specification 92-053-02 or latest version. Pushbuttons shall be 2" in diameter.

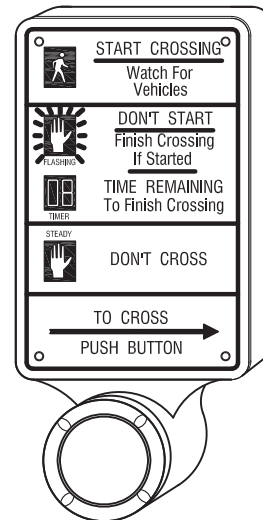

SIDE MOUNTING
TYPE 5 AND 6 STANDARDS ONLY
(See S-72.0A for installation)

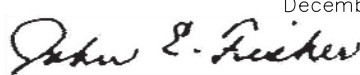
DWN	MT	05-11-05	Title
CKD			PUSHBUTTON
T. E.			
Sr. T. E.			CITY OF LOS ANGELES DEPARTMENT OF TRANSPORTATION
Pr. T. E.	SS	12-9-05	
Approved		December 9, 2005	Drawing No.
 for Frances T. Banerjee, Interim General Manager			S-72.1.1

1/4" INSIDE DIAMETER BRASS GROMMET
4 PLACES (TYP.)



Note: Sign shall be powder coated aluminum with black legend on white background as shown
Material: .063 Aluminum

* Use left, right or double arrow as necessary.

DWN	MT	7-10-08	Title BICYCLE PUSHBUTTON SIGN
CKD	RAR	7-11-08	
T. E.	JV	7-11-08	
Sr. T. E.	JW	7-11-08	
Pr. T. E.			CITY OF LOS ANGELES DEPARTMENT OF TRANSPORTATION
Approved		July 11, 2008	Drawing No.
for <i>John E. Fisher</i>			S-72.2
Rita L. Robinson, General Manager			

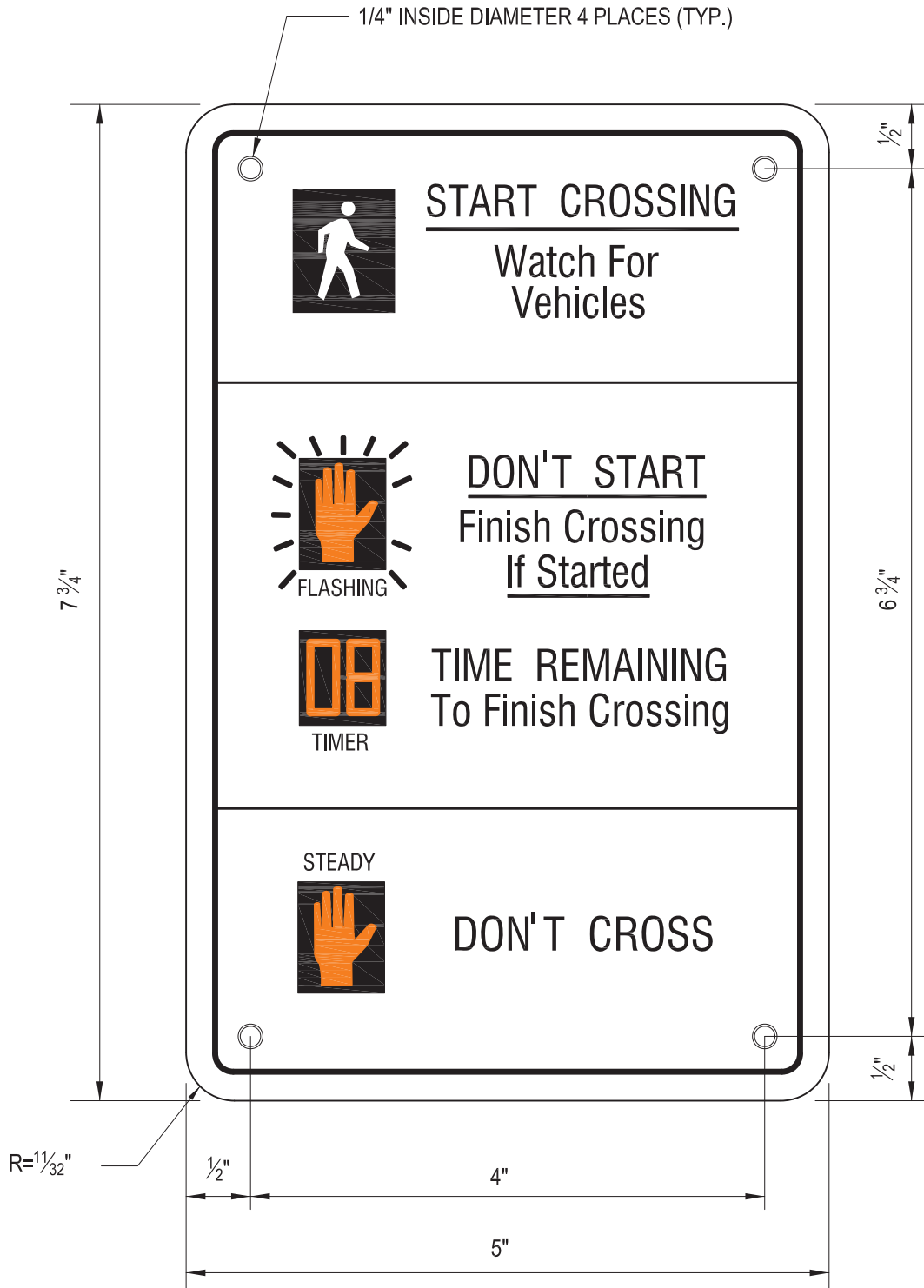

Notes:

1. Sign shall be .063 aluminum.
2. Powder coated with black legend on white background and orange hand and timer symbols.

DWN	MT	6-21-16	Title PEDESTRIAN PUSHBUTTON SIGN NON - ACTUATED	1/1
CKD				
T. E.	JV	6-28-16	CITY OF LOS ANGELES DEPARTMENT OF TRANSPORTATION	Drawing No. S-73.0
Sr. T. E.	MA	8-3-16		
Pr. T. E.	VJ	8-9-16		
Approved		<i>Seleta J. Reynolds</i>	8-9-16	
		Seleta J. Reynolds, General Manager		

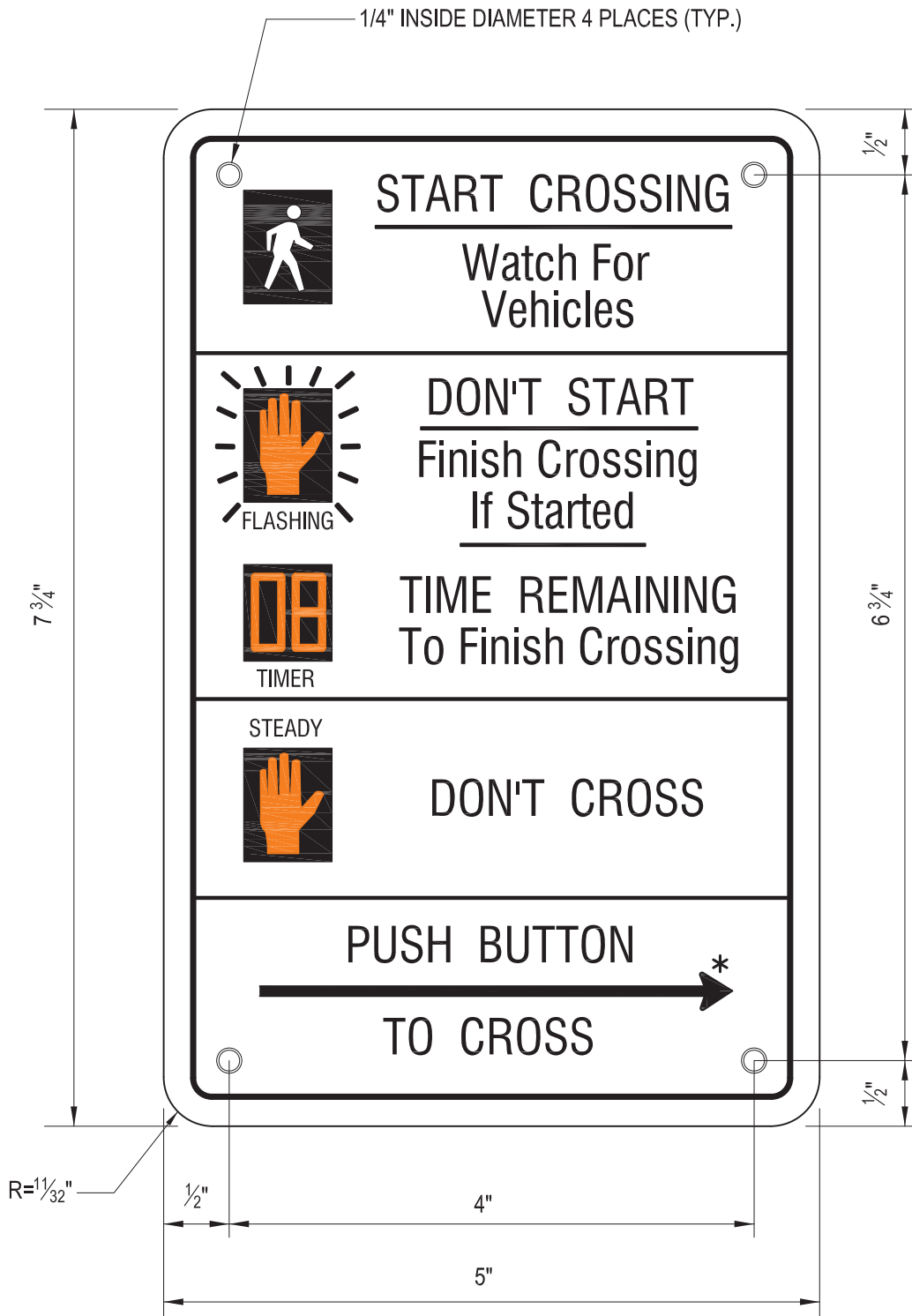

Notes:

1. Sign shall be .063 aluminum.
2. Powder coated with black legend on white background and orange hand and timer symbols.
- * Use left, right or double arrow as necessary.

DWN	MT	6-21-16	Title PEDESTRIAN PUSHBUTTON SIGN ACTUATED	(1/1)
CKD				
T. E.	JV	6-28-16		
CITY OF LOS ANGELES DEPARTMENT OF TRANSPORTATION				
Sr. T. E.	MA	8-3-16		
Pr. T. E.	VJ	8-9-16		
Approved		<i>Seleta J. Reynolds</i>	8-9-16	Drawing No.
Seleta J. Reynolds, General Manager			S-73.1	

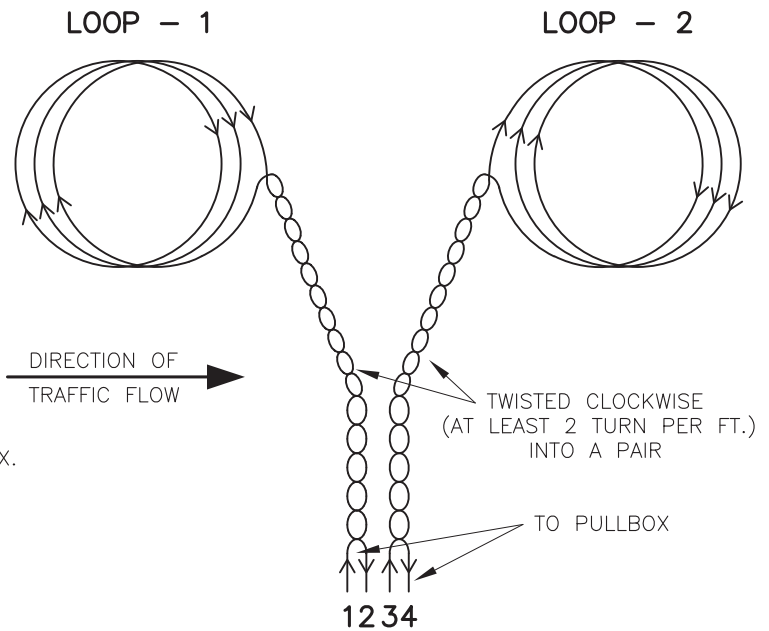
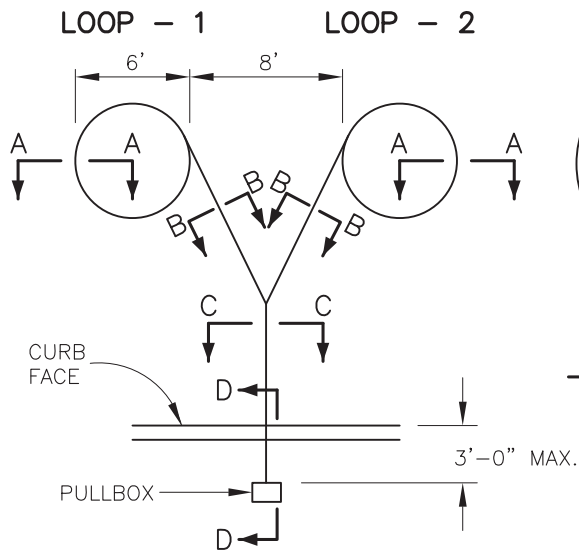

WINDING DETAILS
Not to Scale

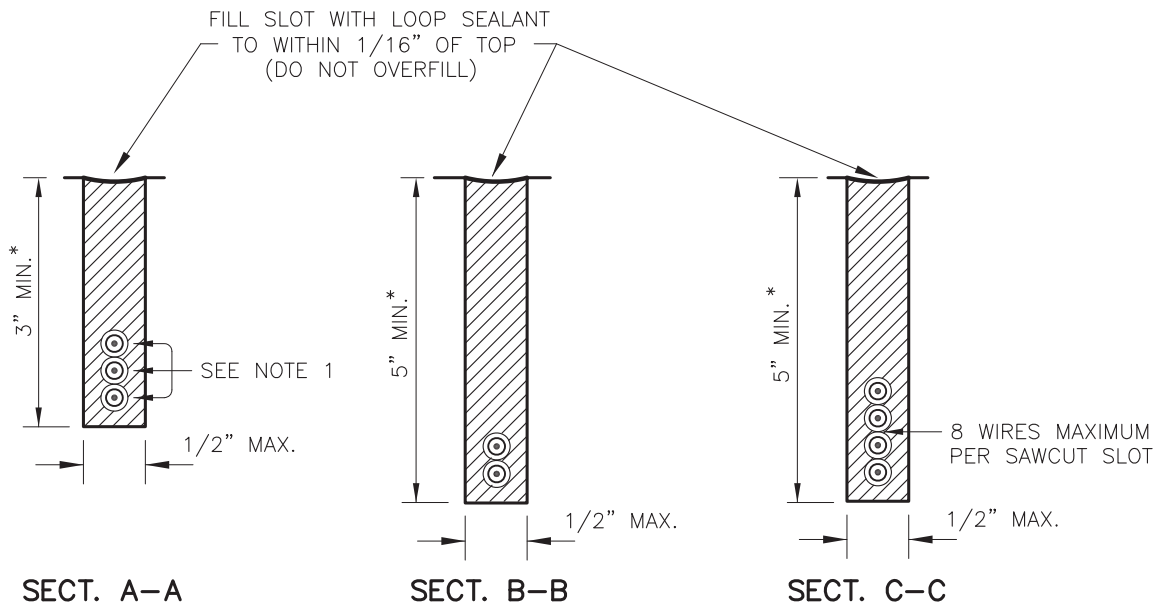

* DEPTH OF SLOT NOT TO EXCEED DEPTH OF PAVEMENT, FOR P.C.C. (CONCRETE) SURFACES, THE MINIMUM COVER ABOVE LOOP WIRE SHALL BE 2.5" MINIMUM.

NOTES:

1. INSTALL 3 CLOCKWISE TURNS OF LOOP WIRE FOR EACH DETECTOR, UNLESS OTHERWISE SHOWN ON SIGNAL PLAN.
2. SEE LADOT MATERIAL SPECIFICATION NO. 92-081-05 OR LATEST REVISION.
3. ANY NON-ROUND SHAPED LOOPS MUST CONFORM TO ALL OTHER SPECIFICATIONS SHOWN ON THIS STANDARD DRAWING.

DWN	MT	6-30-08	Title INDUCTIVE LOOP INSTALLATION
CKD	RAR	7-9-08	
T. E.	JV	7-9-08	
Sr. T. E.	JW	7-9-08	
Pr. T. E.	SS	7-9-08	
Approved <i>John E. Fisher</i> for Rita L. Robinson, General Manager			CITY OF LOS ANGELES DEPARTMENT OF TRANSPORTATION July 9, 2008 Drawing No. S-70.1A

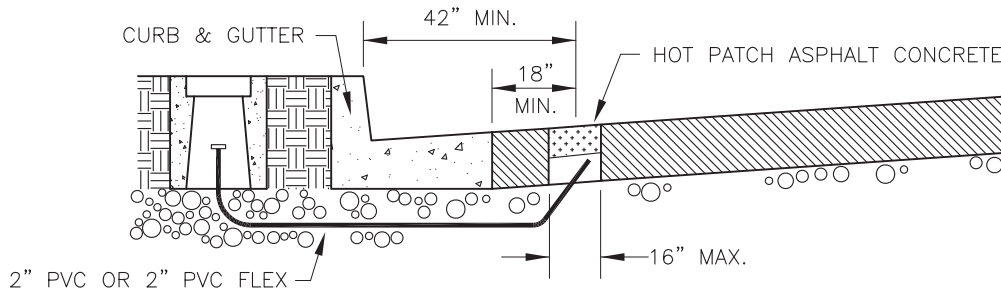

SECTION D-D
NOT TO SCALE

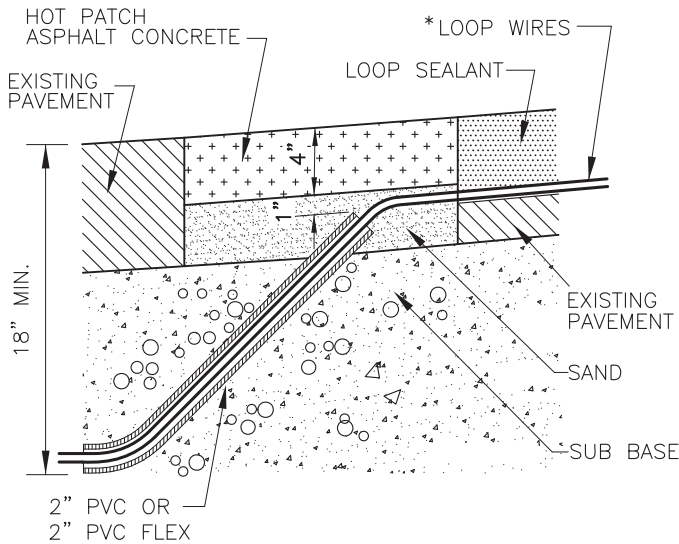

CONDUIT DETAIL
NOT TO SCALE

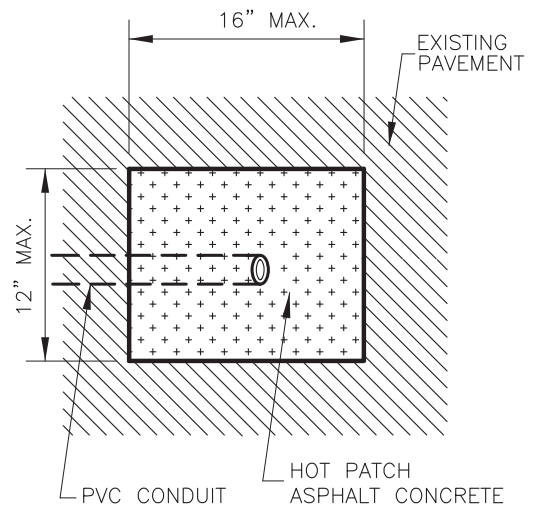

STUB-OUT DETAIL
(Top View)
NOT TO SCALE

NOTES:

Perform Loop Installation in the Following Order:

1. OPEN THE PAVEMENT AT LEAST 42" FROM CURB FACE AND AT LEAST 18" FROM EDGE OF GUTTER USING A STAR DRILL OR A JACKHAMMER (ASPHALT CONCRETE ONLY). OPEN NO MORE THAN A 12" X16" AREA. IN CASES WHERE THERE IS A CONCRETE BUS PAD ADJACENT TO THE GUTTER, INSTALL THE STUBOUT BEYOND THE EDGE OF THE BUS PAD.
2. INSTALL 2" PVC (SC80) OR PVC FLEX (SC40) FROM THE PULLBOX PIT WITH A 45 DEGREE ELBOW AT THE STUB-OUT AS SHOWN. DEPTH OF THE CONDUIT SHALL BE AT LEAST 18" BELOW THE STREET GRADE.
3. PATCH STREET USING HOT PATCH ASPHALT CONCRETE AND SAND AS SHOWN.
4. INSTALL DUCT SEAL WHERE WIRES ENTER 2" PVC OR 2" PVC FLEX.
5. FILL SAWCUT SLOT WITH CALTRANS APPROVED HOT-MELT RUBBERIZED ASPHALT SEALANT.

* NO MORE THAN 8 LOOPS OR 16 WIRES PER STUB-OUT.

CITY OF LOS ANGELES
DEPARTMENT OF TRANSPORTATION

Title
INDUCTIVE LOOP INSTALLATION $\frac{2}{2}$

Drawing No.
S-70.1A

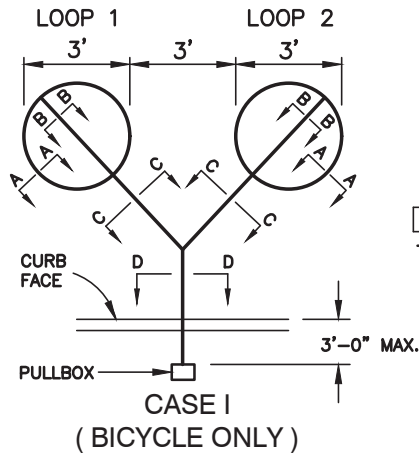
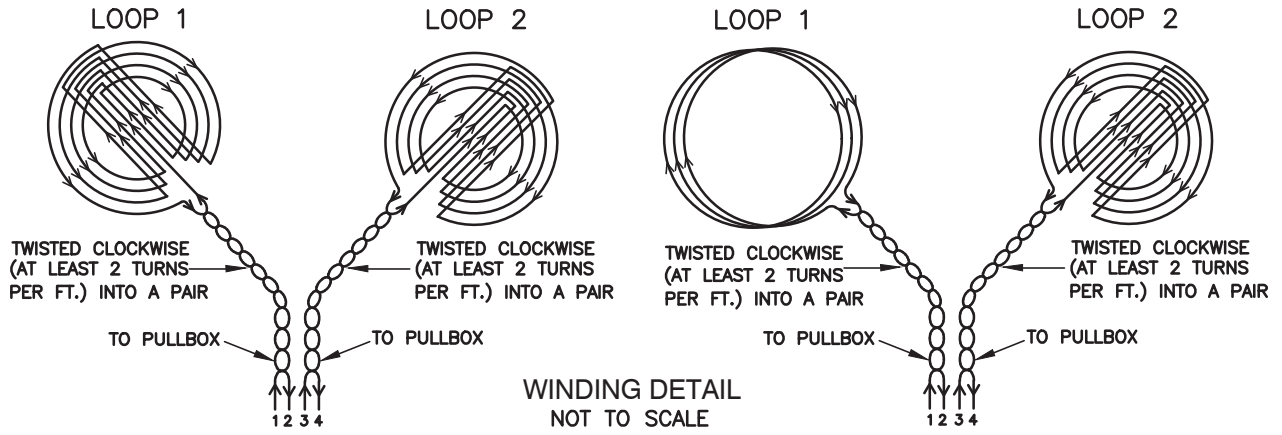

DIRECTION OF
TRAFFIC FLOW

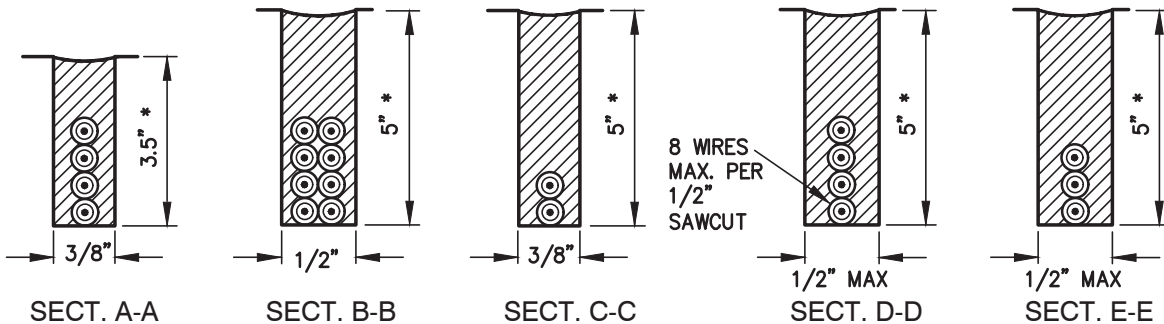
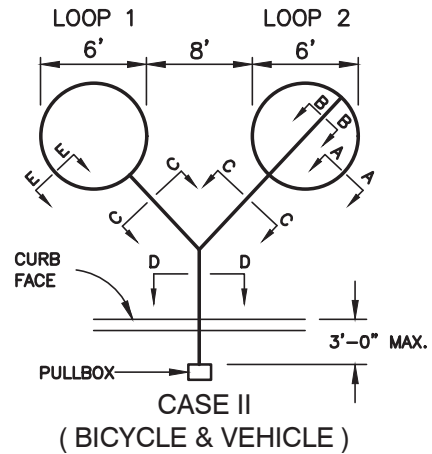

* DEPTH OF SLOT NOT TO EXCEED DEPTH OF PAVEMENT

Notes:

- INSTALL FOUR (4) COMPLETE ALTERNATING TURNS OF LOOP WIRES, UNLESS OTHERWISE SPECIFIED.
- FOR STUB-OUT AND CONDUIT DETAILS REFER TO PAGE 2 OF S-70.1A.
- SEE LADOT MATERIAL SPECIFICATION NO. 92-081-05 OR LATEST REVISION.
- USE CASE I LOOPS FOR BIKE LANE INSTALLATIONS. USE CASE II LOOPS WHEN VEHICULAR LOOPS ARE INTENDED TO DETECT BICYCLES.
- AN OCTAGONAL SHAPED LOOP OR OTHER NON-ROUND SHAPED LOOP MAY BE USED INSTEAD OF THE ROUND-LOOP WITH PRIOR LADOT APPROVAL.
- SAME WINDING PATTERN TO BE USED IN BOTH LOOPS FOR CASE 1 WITH 1 PAIR FROM EACH LOOP LEADING TO THE PULLBOX.
- LOOPS INSTALLED IN BIKE LANES WITH PARKING SHALL BE PLACED WITH THE NEAR EDGE OF THE LOOP 1 TO THE RIGHT OF THE BIKE LANE DELINEATION LINE, UNLESS OTHERWISE SPECIFIED.
- LOOPS INSTALLED IN BIKE LANES ADJACENT TO THE ROADSIDE WITHOUT PARKING SHALL BE CENTERED IN THE BIKE LANE, OR BETWEEN THE GUTTER AND THE BIKE DELINEATION LINE, UNLESS OTHERWISE SPECIFIED.
- ANY LADOT APPROVED NON-ROUND SHAPED LOOPS MUST CONFORM TO ALL OTHER SPECIFICATIONS SHOWN ON THIS STANDARD DRAWING.

DWN	MT	3-07-17	Title	BICYCLE DETECTOR 1/1
CKD				
T. E.	JV	3-7-17	CITY OF LOS ANGELES DEPARTMENT OF TRANSPORTATION	
Sr. T. E.	MA	4-27-17		
Pr. T. E.	VJ	4-28-17		
Approved				Date 5-11-17
				Drawing No. S-70.1D
Seleta J. Reynolds, General Manager				

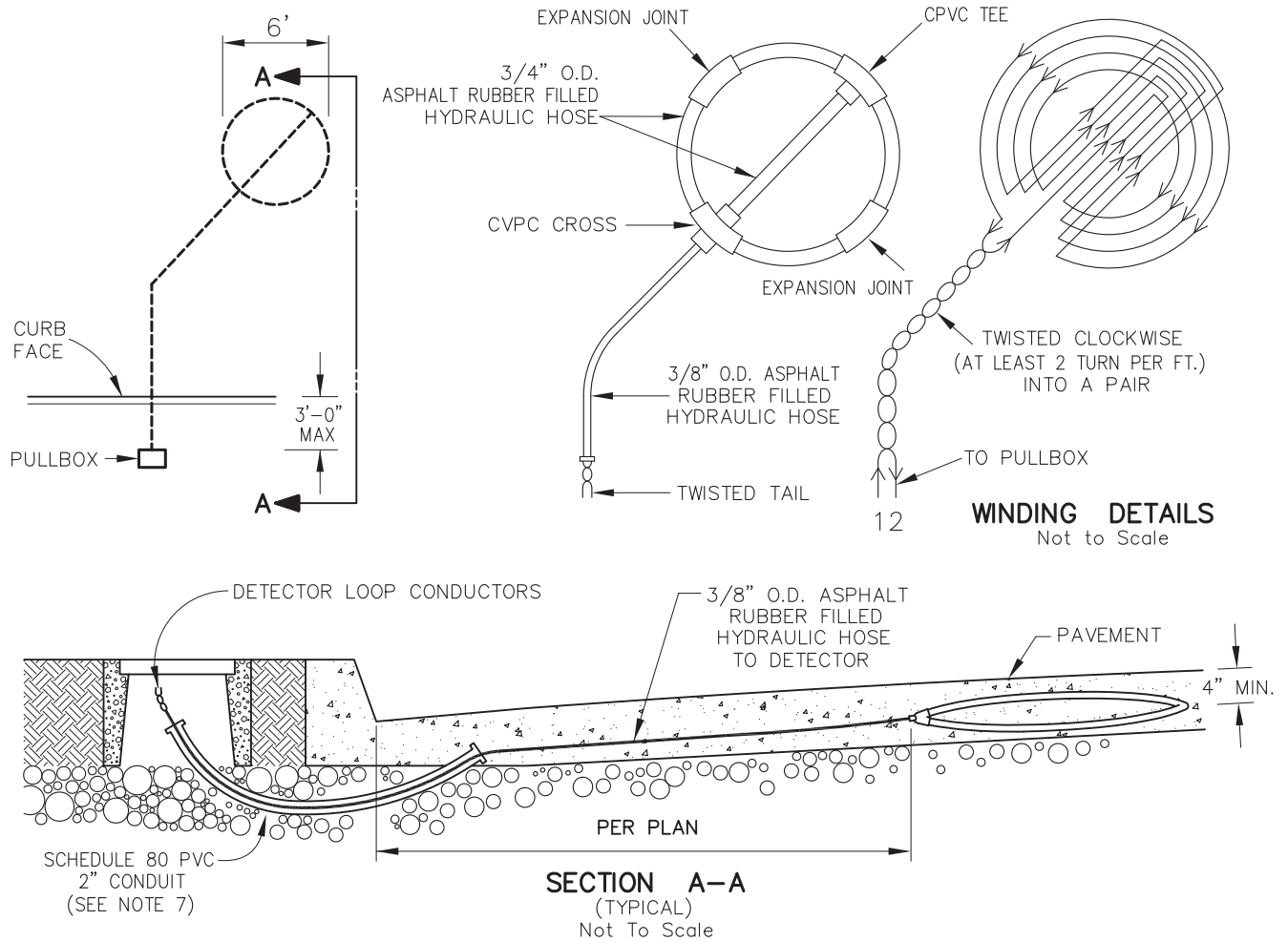

NOTES:

1. PRE-FORMED LOOP SHALL BE CONSTRUCTED FROM 1/2" I.D. POLYPROPYLENE, WITH AN O.D. OF 3/4" INCH.
2. LOOP IS TO HAVE ONE CONTINUOUS #16 TFFN WIRE THROUGH THE LOOP HEAD AND LEAD-IN TO PREVENT LOOP MALFUNCTION DUE TO SPLICING. LOOP SHALL HAVE FOUR (4) TURNS OF WIRE.
3. THE CONDUIT SHALL BE COMPLETELY FILLED WITH HOT, RUBERIZED ASPHALT WHICH WILL ALLOW THE LOOP TO RETAIN FLEXIBILITY ONCE COOLED, PREVENT INCURSION OF MOISTURE AND SET THE WIRE TURNS FIRMLY IN PLACE.
4. EACH LOOP HEAD SHALL BE PROVIDED WITH A 5" CONTRACTION/EXPANSION JOINT TO ALLOW FOR MOVEMENT OF PAVEMENT AND TO PREVENT BREAKAGE OF THE WIRE AND/OR CONDUIT. THE JOINT IS TO HAVE A 9" LONG BY 3/4" SCHEDULE 80 PVC COVER SLIDE TO BE PLACED OVER THE JOINT FOR PROTECTION FROM THE ELEMENTS.
5. ENCASE LEAD-IN WIRES IN A NON-CONDUCTIVE 250 PSI FLEX HOSE SEAMLESS FIBER BRAID REINFORCEMENT AND A NON-CONDUCTIVE SEAMLESS EXTRUDED URETHANE NON-PERFORATED JACKET. FILL LEAD-IN HOSE COMPLETELY WITH HOT RUBBERIZED ASPHALT. TWIST WIRES AT LEAST TWO TIMES PER FOOT FOR ENTIRE RUN. ATTACH LEAD-IN TO LOOP HEAD WITH A SCHEDULE 80 CVPC TEE AND A CVPC ADAPTER BUSHING.
6. ANY VARIATION TO THE INSTALLATION AS DESCRIBED ABOVE SHALL BE APPROVED BY THE DESIGN ENGINEER PRIOR TO INSTALLATION.
7. THE 3/8" O.D. LEAD-IN HOSE SHALL BE INSTALLED IN 2" PVC CONDUIT BETWEEN PULLBOX AND ENTRY TO PAVEMENT SLAB. LOOP SHALL BE ATTACHED TO TOP OF REINFORCING BARS WHEN USED IN THE PAVEMENT SLAB.

Drawn By	RMO	02-12-99	Title	PREFORMED LOOP INSTALLATION <div style="text-align: right; border: 1px solid black; border-radius: 50%; width: 20px; height: 20px; display: flex; align-items: center; justify-content: center; margin: 0 auto;"> 1/1 </div>
Checked By	AM	3-30-98		
Supervised By	KF	02-12-99		
Reviewed By	TLJ	02-12-99		
Revision			CITY OF LOS ANGELES DEPARTMENT OF TRANSPORTATION	
Rev. distance	JV	5-6-08	Approved	 <small>Frances T. Sanchez, General Manager</small>
			2-16-99	Drawing No.
				S-70.1E

LENGTH OF LOOP	NUMBER OF TURNS
< 40'	2
≥ 40'	1

SAW SLOT DETAIL

WINDING DETAIL

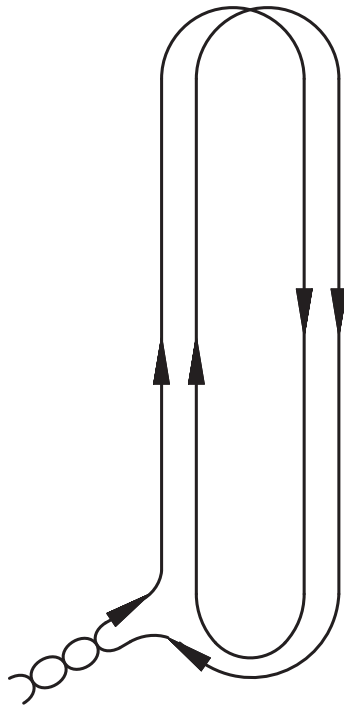

2 TURNS

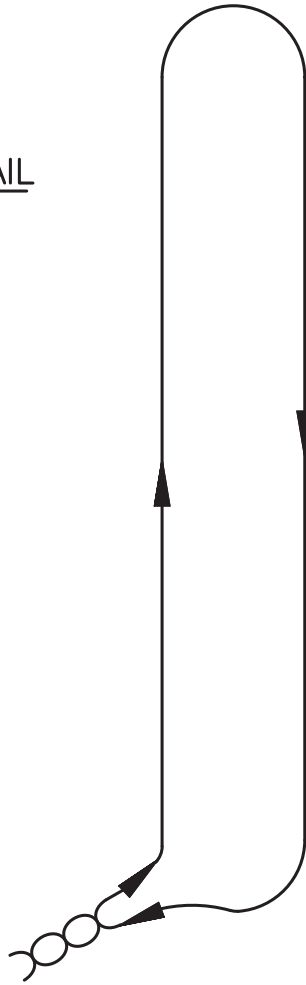

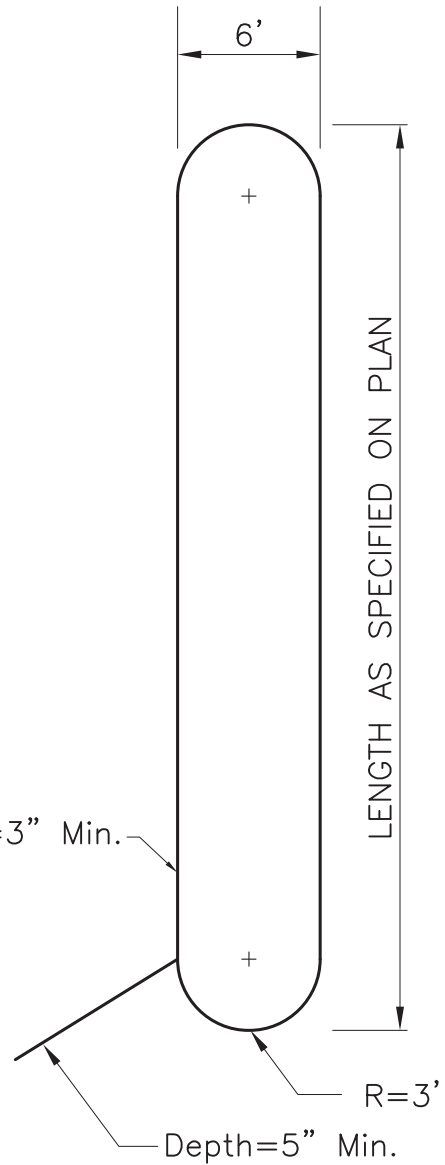

1 TURN

Depth=3" Min.



SYMBOL

DWN	TH	12-04-00	Title	TRANSIT PRIORITY LOOP 
CKD	MD	12-04-00		
T. E.	MD	12-04-00		
Sr. T. E.	SS	12-04-00	CITY OF LOS ANGELES DEPARTMENT OF TRANSPORTATION	
Pr. T. E.	GO	3-14-01		
Approved		4-5-2001		Drawing No.
 Frances T. Benerjee, General Manager		S-70.1F		

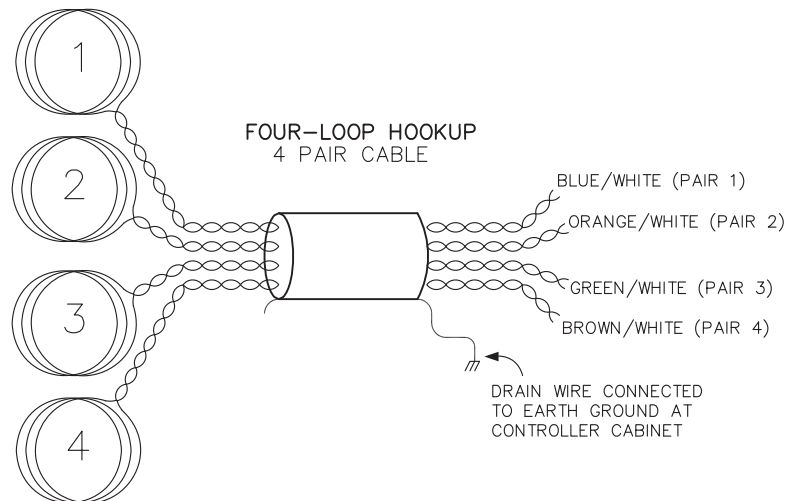
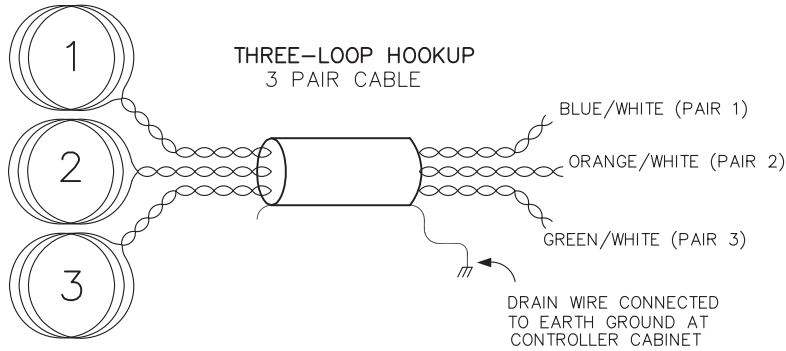
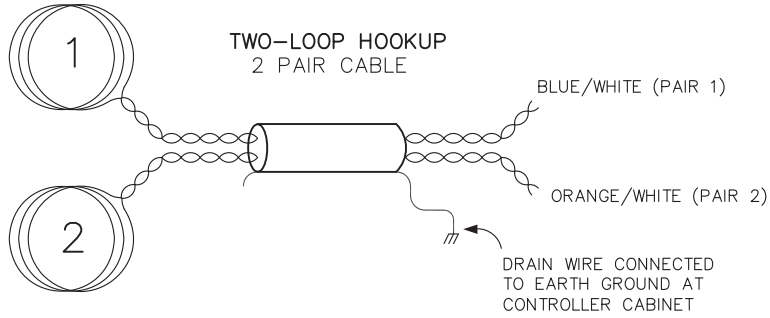
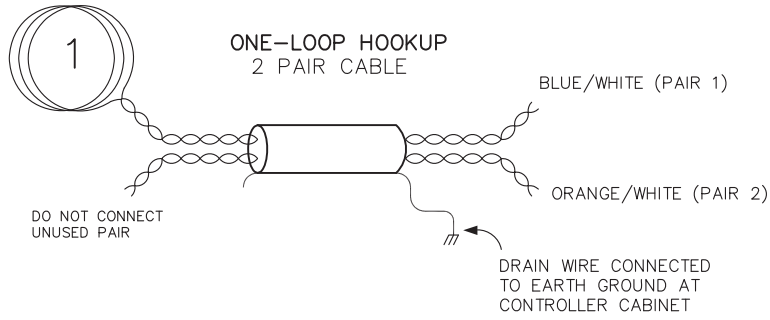

NOTES:

1. THIS STANDARD DRAWING DESCRIBES A TWO, THREE OR FOUR PAIR LOOP DETECTOR LEAD-IN CABLE, INDIVIDUALLY SHIELDED AND JACKETED AND SUITABLE FOR INSTALLATION IN A PAVEMENT SAWCUT, CONDUIT, OR DIRECT BURIAL.
2. THE DETECTOR LEAD-IN CABLE CAN BE WIRED IN EITHER A SINGLE, DOUBLE, TRIPLE OR QUADRUPEL CHANNEL CONFIGURATION.
3. ELECTRICAL CONNECTIONS SHALL BE CAREFULLY SOLDERED AND WATERPROOFED.
4. SEE LADOT MATERIAL SPECIFICATION NO. 92-082-03 OR LATEST REVISION.
5. LOOP NUMBERS SHOWN ARE TYPICAL.
6. SYSTEM LOOPS USE A SINGLE PAIR FOR EACH LOOP.

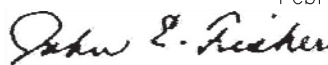
DWN	MT	10-19-04	Title SYSTEM DETECTOR LOOP LEAD-IN CABLE (2,3,4 PAIR)	1/1
CKD				
T. E.			CITY OF LOS ANGELES DEPARTMENT OF TRANSPORTATION	
Sr. T. E.				
Pr. T. E.	TLJ	2-25-05		
Approved		February 25, 2005		Drawing No.
 for Wayne K. Tanda, General Manager				S-70.2

Actuation/ Phase Loops

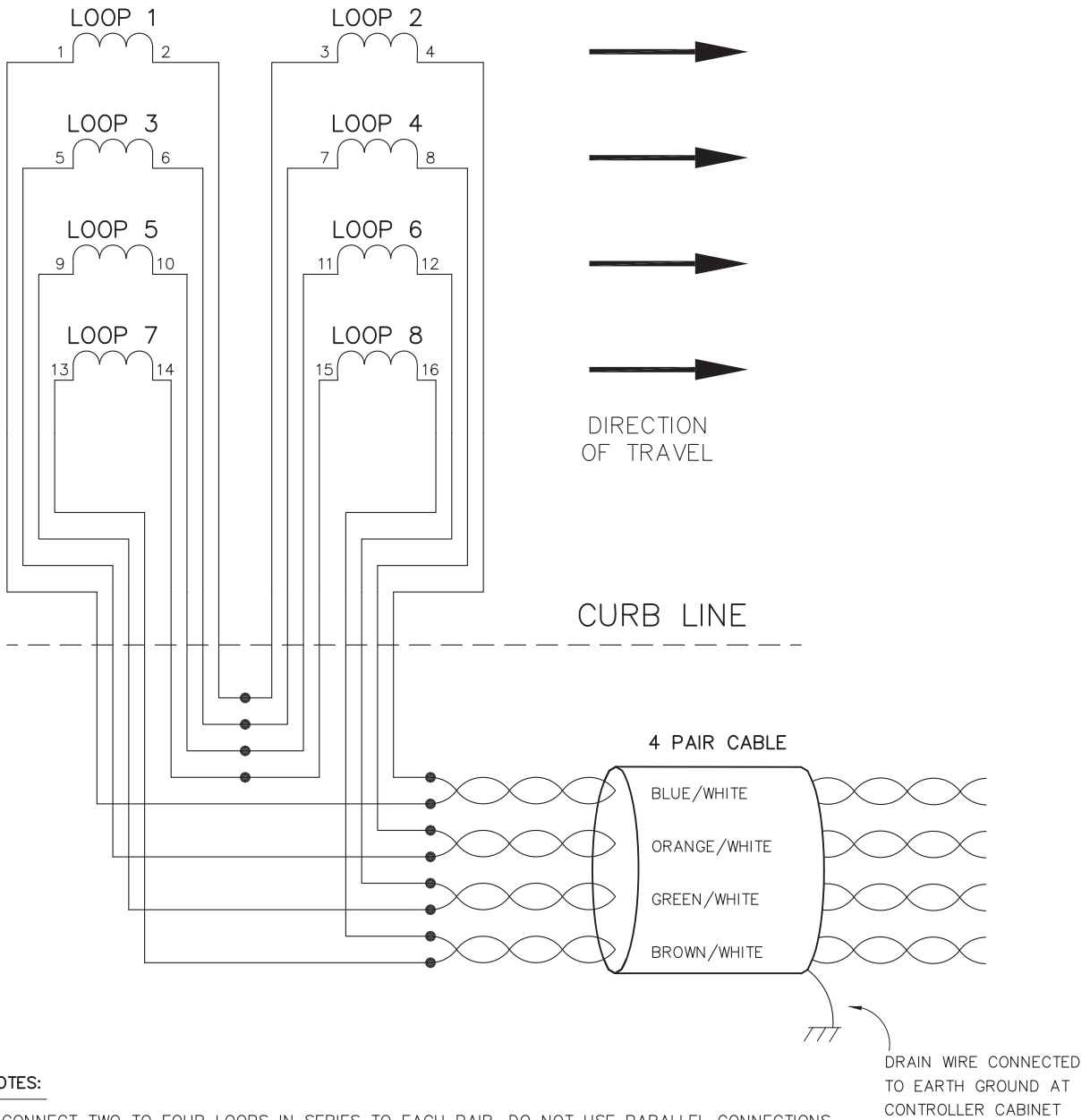

NOTES:

1. CONNECT TWO TO FOUR LOOPS IN SERIES TO EACH PAIR, DO NOT USE PARALLEL CONNECTIONS.
2. DO NOT CONNECT ANY UNUSED CABLE PAIRS.
3. TYPICAL INSTALLATION SHOWN. TWO OR THREE PAIR CABLE MAY BE USED WHEN SHOWN ON SIGNAL PLAN.

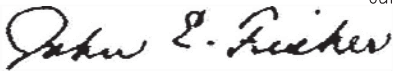
DWN	MT	05-07-08	Title	MULTI-PAIR LOOP LEAD-IN CABLE <div style="float: right; border: 1px solid black; border-radius: 50%; width: 30px; height: 30px; display: flex; align-items: center; justify-content: center;">1/1</div>
CKD				
T. E.				
Sr. T. E.				
Pr. T. E.			CITY OF LOS ANGELES DEPARTMENT OF TRANSPORTATION	
Approved		June 26, 2008		Drawing No.
 for Rita L. Robinson, General Manager				S-70.3

LRT DETECTOR FOR EXISTING TRACK (EMBEDDED)

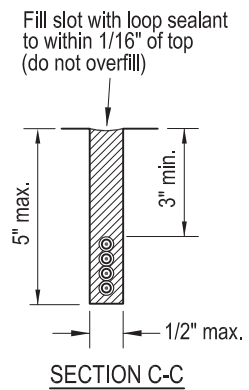
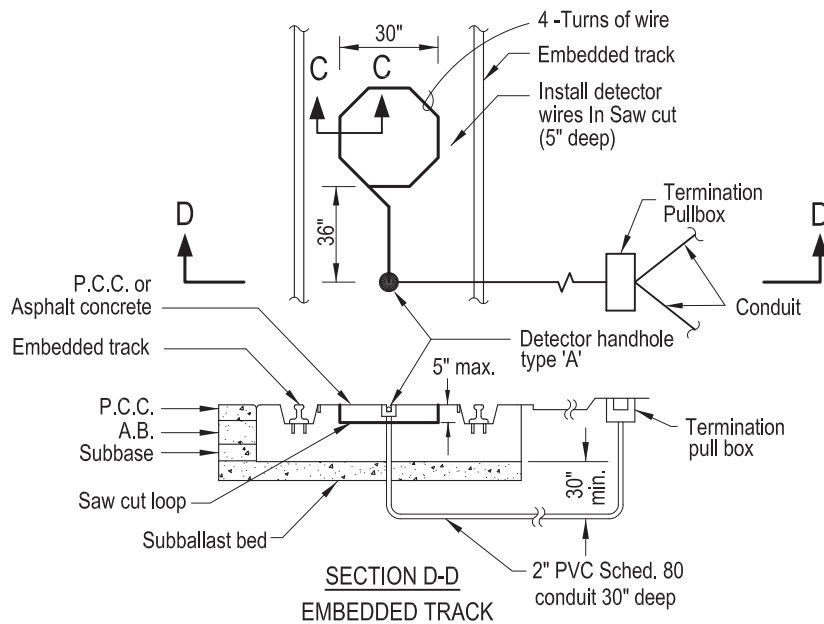

Notes:

1. Saw cut loops (octagonal or circular) to be used for existing installations only.
2. See LADOT Std. Dwg. S-70.1.A for inductive loop installation details not shown hereon.

LRT DETECTOR FOR NEW TRACK (BALLASTED)

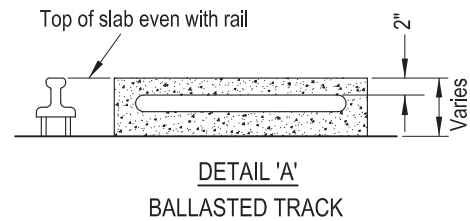
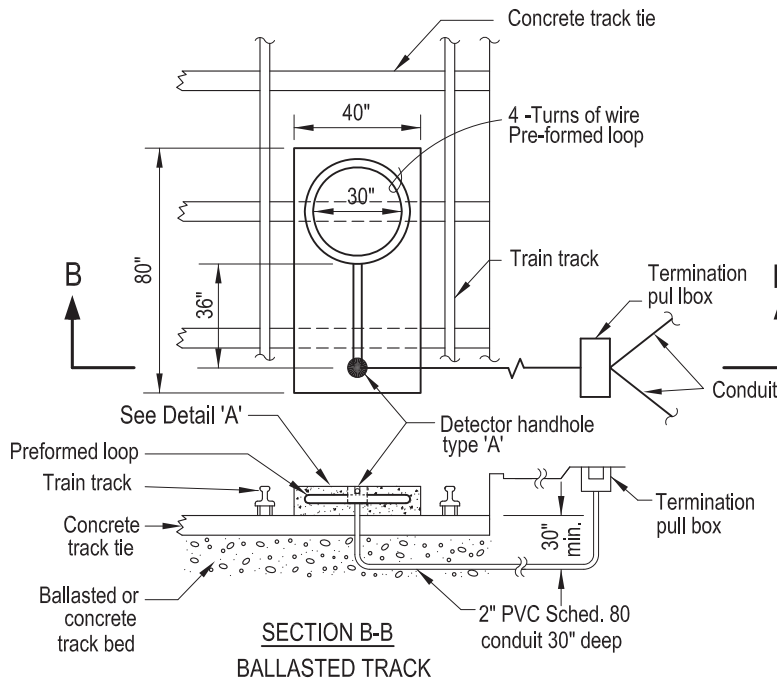

Notes:

1. Preformed loop to be used for all new construction.
2. See current LADOT material specification for traffic loop.
3. See page 2 and 3 for preformed LRT loop details.

DWN	MT	8-7-14	Title	<h3 style="margin: 0;">Light Rail Train (LRT) Track Detector Loop</h3> <div style="text-align: right; border: 1px solid black; border-radius: 50%; width: 30px; height: 30px; display: flex; align-items: center; justify-content: center; margin: 0 auto;">1/3</div>
CKD				
T. E.	BC	8-7-14		
Sr. T. E.				
Pr. T. E.	SS	8-7-14	CITY OF LOS ANGELES DEPARTMENT OF TRANSPORTATION	
Approved			8-8-2014 Jon Kirk Mukri, General Manager	Drawing No. <h2 style="margin: 0;">S-70.4A</h2>

LRT DETECTOR FOR NEW TRACK (EMBEDDED)

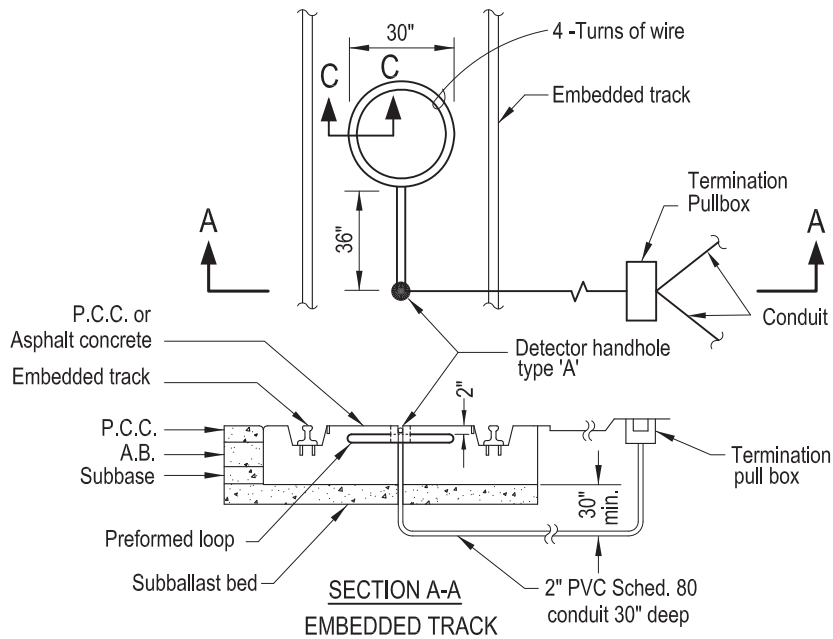

Notes:

1. Preformed loop to be used for new installations in embedded track..
2. No rebar or metal of any kind other than the track rails shall be placed within three feet (3') horizontally or vertically from LRT loop.
3. See page 2 and 3 for preformed LRT loop details..

LRT PREFORMED LOOP DETAILS

Notes:

1. Pre-formed loop shall be constructed from 1/2" I.D. Polypropolene, with an O.D. of 3/4 inch.
2. Loop is to have one continuous #16 TFFN wire through the loop head and lead-in to prevent loop malfunction due to splicing. Loop shall have four (4) turns of wire.
3. The conduit shall be completely filled with hot, rubberized Asphalt which will allow the loop to retain flexibility once cooled, prevent incursion of moisture and set the wire turns firmly in place.
4. Each loop head shall be provided with a 5" contraction/expansion joint to allow for movement of pavement and to prevent breakage of the wire and/or conduit. The joint is to have a 9" long by 3/4" schedule 80 PVC cover slide to be placed over the joint for protection from the elements.
5. Encase lead-in wire in a non-conductive 250 psi Flex hose, seamless, with fiber braid reinforcement and a non-conductive seamless extruded Urethane non-perforated jacket. Fill lead-in-hose completely with hot rubberized Asphalt. Twist wires at least two times per foot for entire run. Attach lead-in to loop head with a schedule 80 CVPC tee and a CVPC adapter bushing.
6. Any variation to the installation as described above shall be approved by the design engineer prior to installation.

CITY OF LOS ANGELES DEPARTMENT OF TRANSPORTATION	Title Light Rail Train (LRT) Track Detector Loop	Drawing No. S-70.4A
---	--	-------------------------------

LRT PREFORMED LOOP DETAILS (CONT'D)

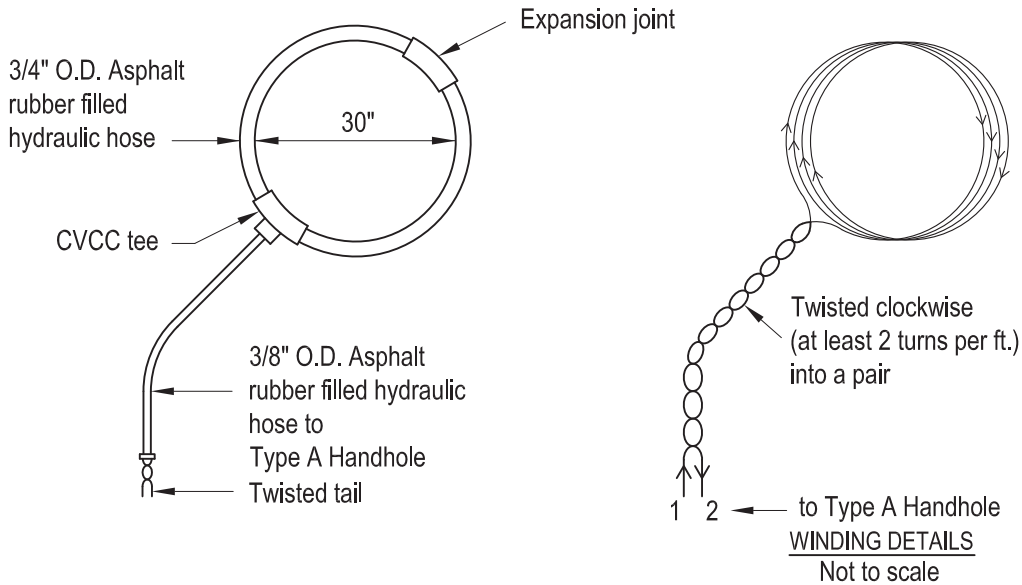

TYPE 'A' LRT DETECTOR HANDHOLE

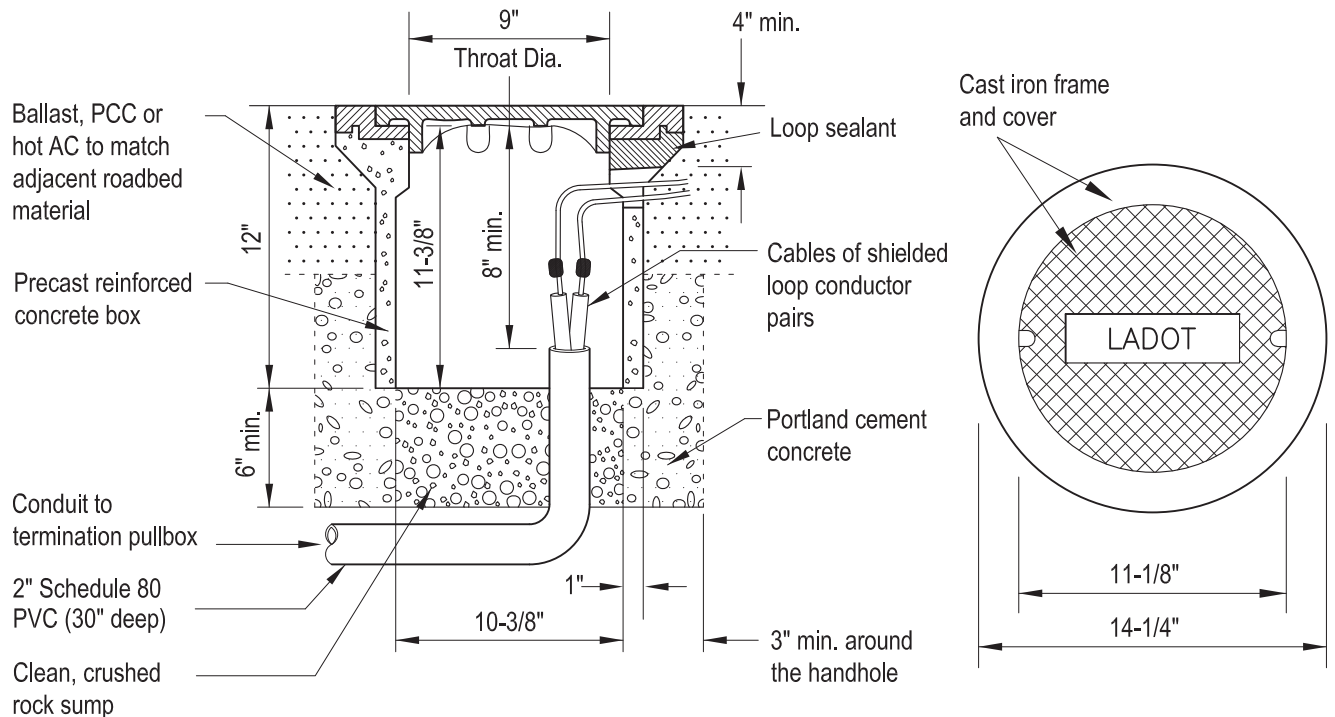

Notes:

1. Splices shall only be made in the handhole.
2. Splices shall be soldered and water proofed.

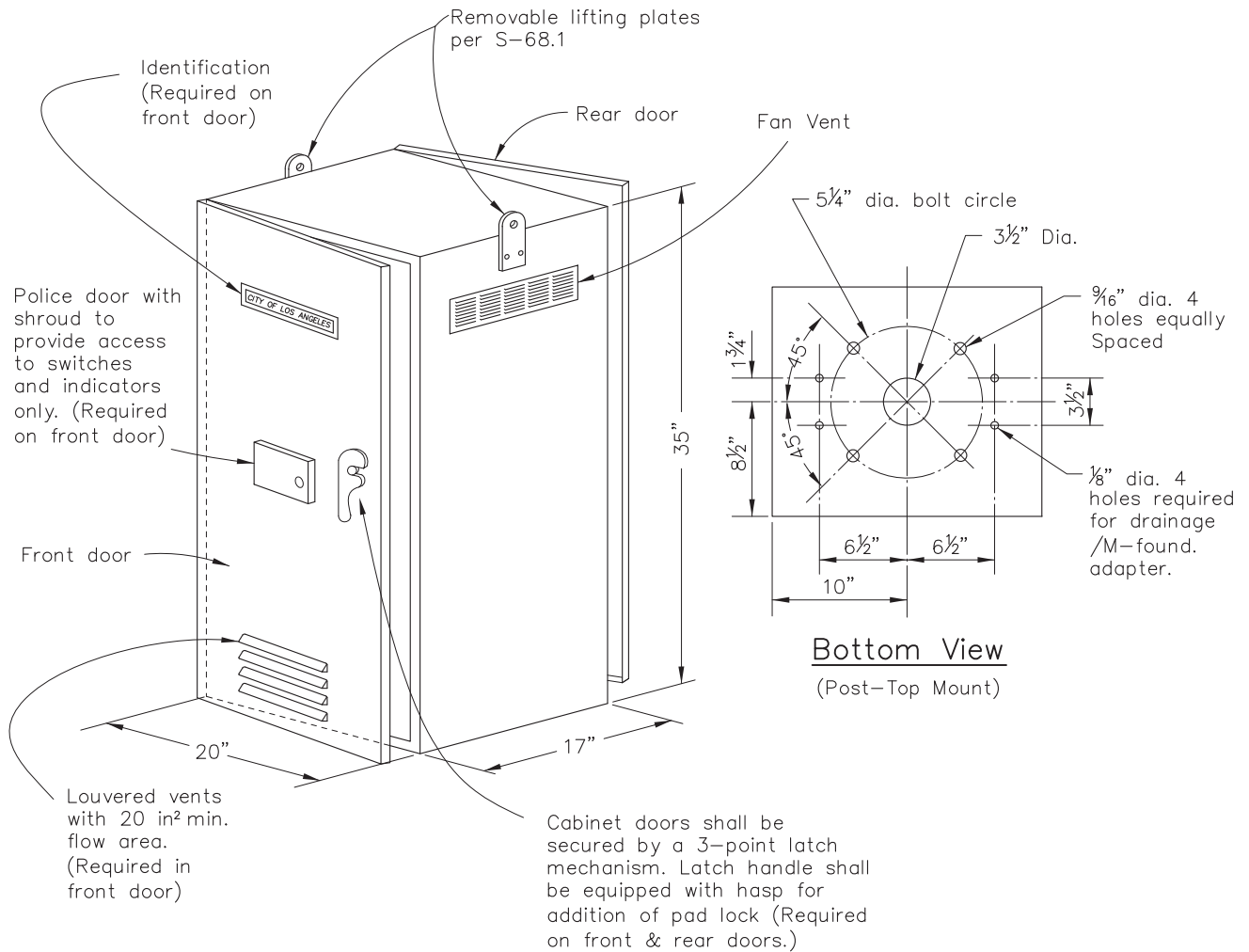

Notes:

1. Cabinet construction, ventilation requirements and other necessary accessories shall conform to the latest specification for "Cabinet Assembly - Type 337 post - top mounted", Dept. of Transportation, City of Los Angeles.
2. Cabinet shall be equipped with rails for mounting equipment. Rails shall be of standard 19" rack configuration.

Type	Foundation
Type 337 (Post - top mounted)	F-8

Cabinet Details

Dimension Tolerance ±0.125 inch

Drawn By	JC	5-8-84	Title	337 Cabinet (Post-top mounted)
Checked By	RO	5-9-84		
Supervised By	JK	5-9-84		
Reviewed By	JAC	5-14-84		
R e v i s i o n s			CITY OF LOS ANGELES DEPARTMENT OF TRANSPORTATION Donald R. Howery, General Manager	
Revised	JK JMO	JAC	2-15-85	Approved <u>May 15, 1984</u> Donald R. Howery General Manager
Revised	JMO	RMO	9-18-86	
Revised	JMO	RMO	3-4-87	
CHANGE 170 TO 337	SS		8-2-07	
			Approved	DRAWING NO. S-75.9A

▽ Note:

1. When this cabinet is used as an ATSAC type I communication cabinet, A one-inch (1") screened drain pipe shall be provided through the foundation. A 19" X 33" or larger 3/4-inch thick plywood mounting panel shall be installed on the inside of the rear wall. Machine screws and bolts shall not protrude beyond the outside wall of the cabinet.

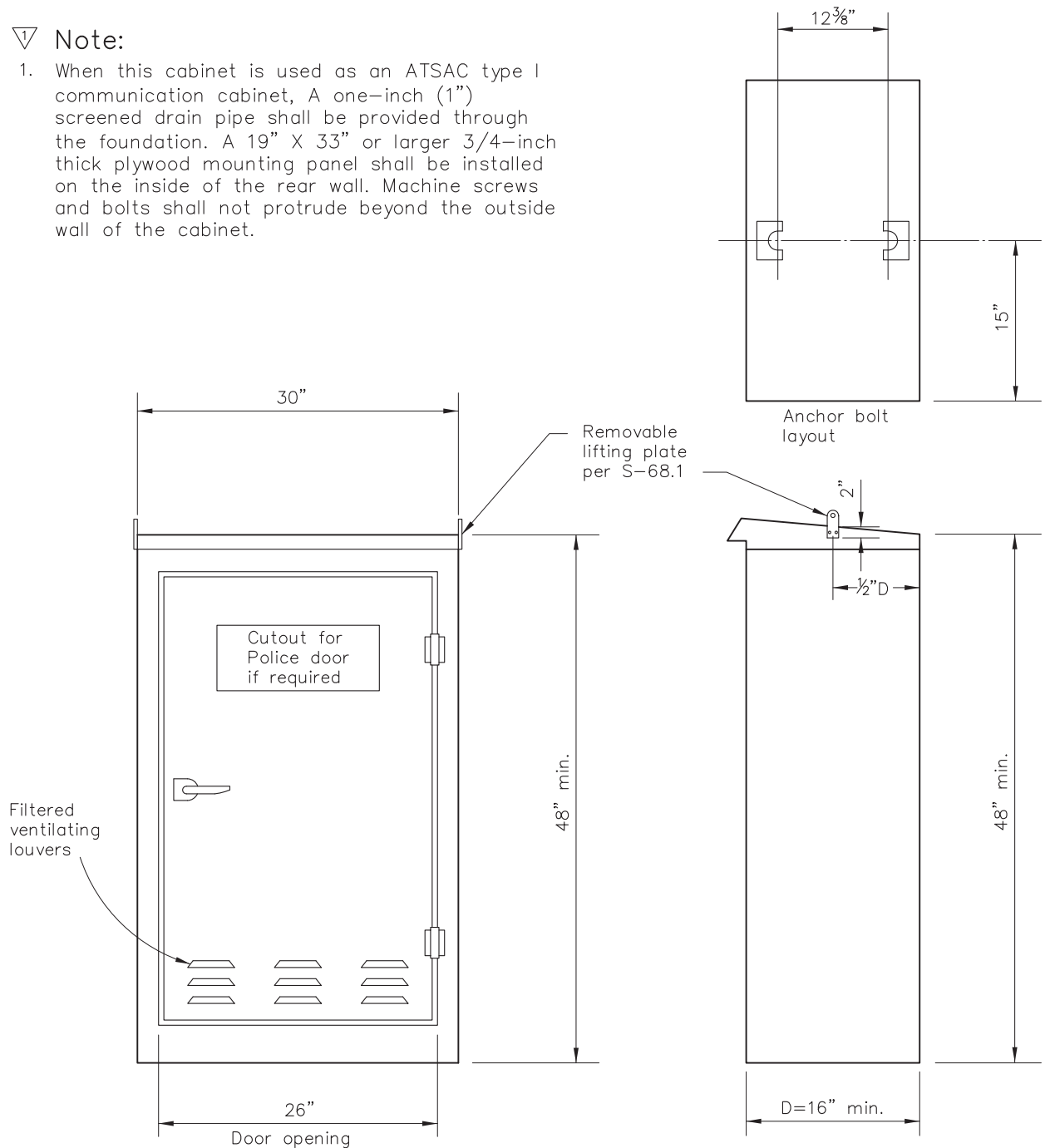

Type	Foundation
M	F-12A

▽ Specification No. 92-044-04 or latest revision

RO ▽ ▽	Drawn By	FAS	7-22-82	Title Cabinet, Controller Type M CITY OF LOS ANGELES DEPARTMENT OF TRANSPORTATION Donald R. Howery, General Manager
	Checked By	RO	7-29-82	
	Supervised By	JF	8-2-82	
	Reviewed By	JAC	8-2-82	
	R e v i s i o n s			
Add. rem. lift'g pl.	JAC	1-22-83	Approved <u>August 2, 1982</u>	DRAWING NO. S-75.5.3
added notes	GH	6-5-90	Donald R. Howery	
Update spec. no.	TLJ	2-16-05	General Manager 9/87	

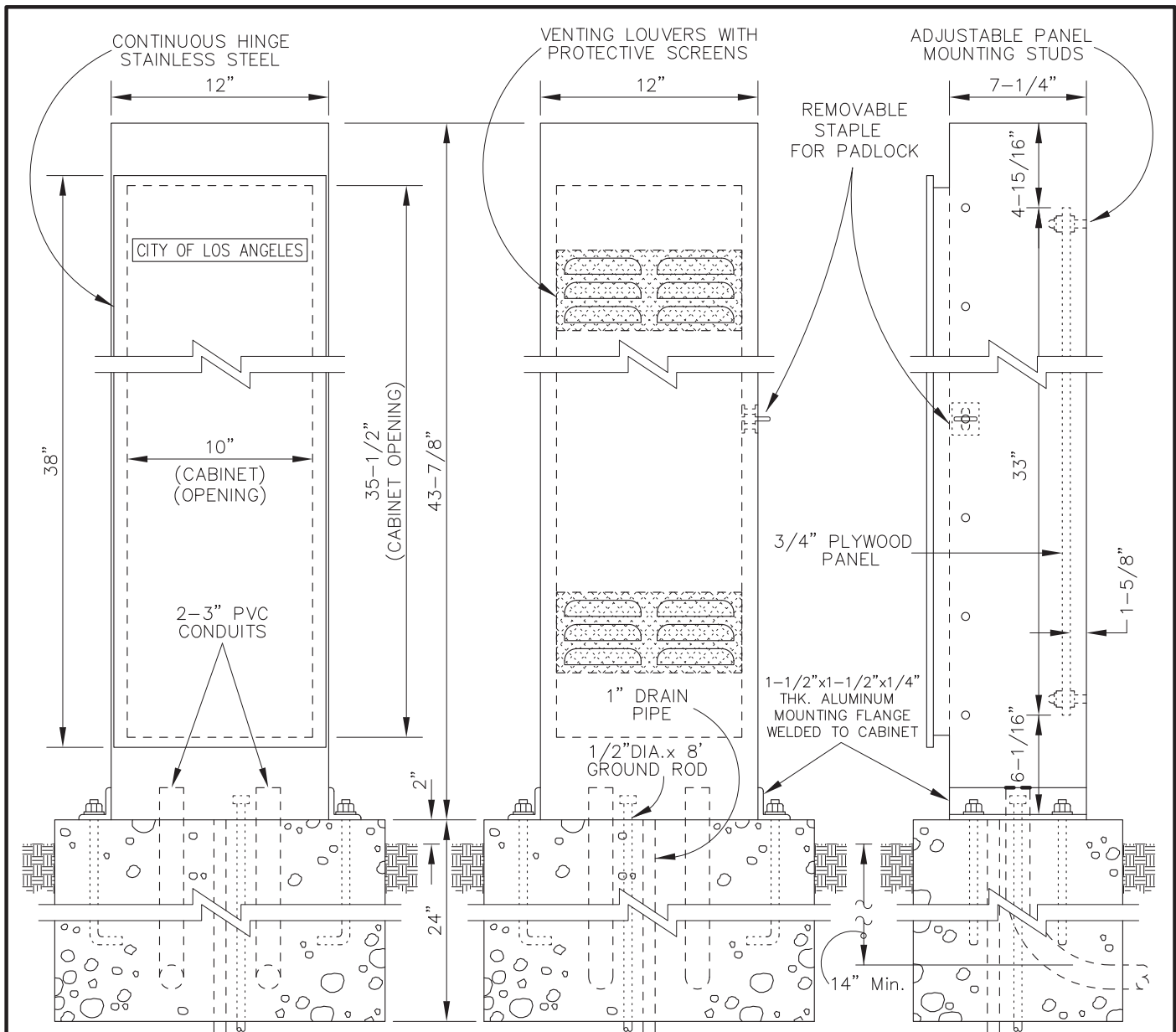

FRONT VIEW

REAR VIEW

SIDE VIEW

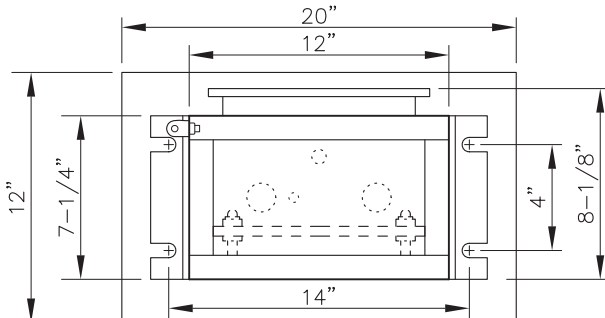

PLAN VIEW

NOTES:
 MATERIAL -
 .125" THK. AL 5052 H32
 FINISH -
 ANODIZED PER
 MIL-A-8625C SPEC.

SPEC. NO. 92-067-02

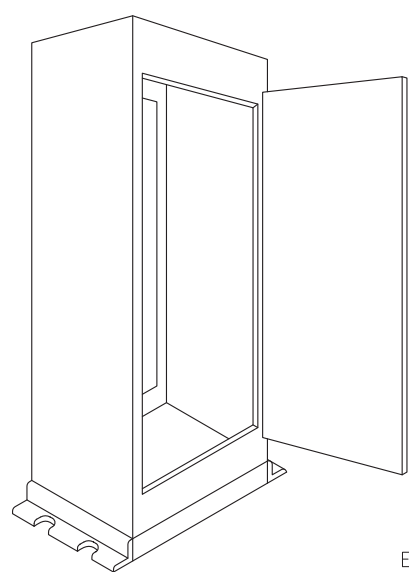

Drawn By	RMO	12-20-90	Title	TYPE II COMMUNICATION CABINET & FOUNDATION	
Checked By	ERA	1-10-91	CITY OF LOS ANGELES DEPARTMENT OF TRANSPORTATION S. E. ROWE, General Manager		
Supervised By	JEM	1-14-91			
Reviewed By			Approved _____ 2-22-91 S. E. Rowe General Manager		
Revisions					
Supersedes S-75.0B	ERA	2-12-91	DRAWING NO. S-75.0C		
Show fnd. 2" above surface	JEM	2-27-91			

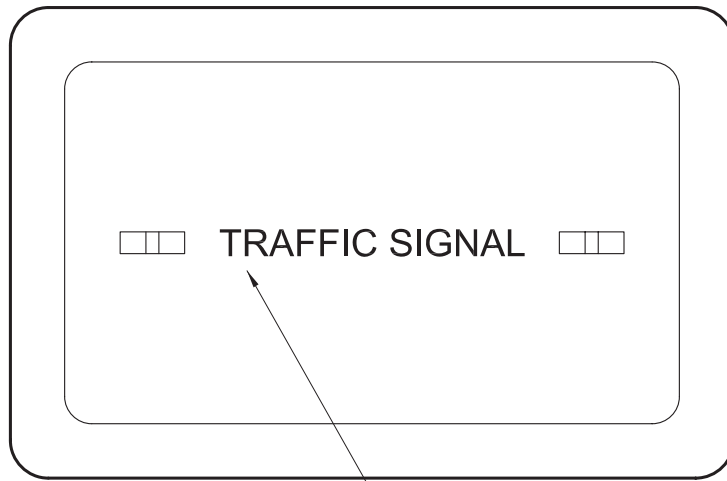

1" letters cast or stamped in lid

See Note 3

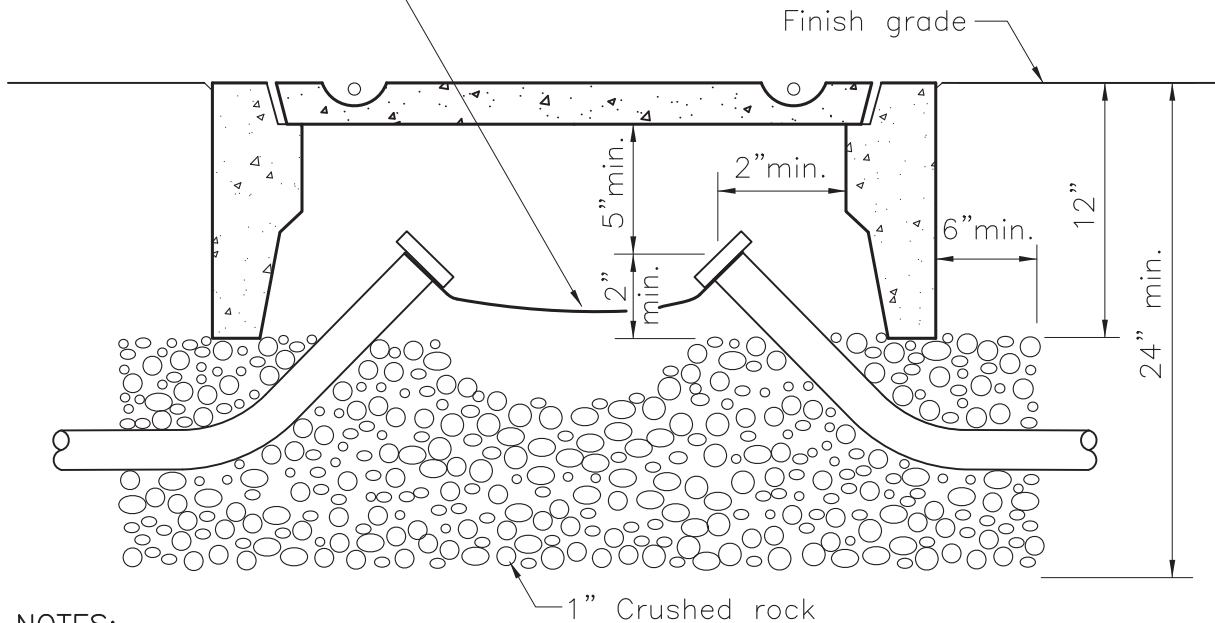

NOTES:

1. Pullbox details not shown on this plan shall conform to Dept. of Public Works Standard Drawing # L-201-0.
2. Outside Dimension: Type PB2- 15"X25", Type PB3- 22"X34"
3. Galvanized conduits must be bonded with copper ground strap around the neck of each conduit . PVC conduits must have their #8 green ground wires spliced together.

DWN	MT	11-8-11	Title PULL BOX, TYPES PB-2 & PB-3	(1/1)
CKD				
T. E.				
Sr. T. E.			CITY OF LOS ANGELES DEPARTMENT OF TRANSPORTATION	
Pr. T. E.	SS	12-8-11		
Approved		<i>John E. Fisher</i> 12-8-11		Drawing No.
		for Jaime de la Vega, General Manager		S-78.5.1

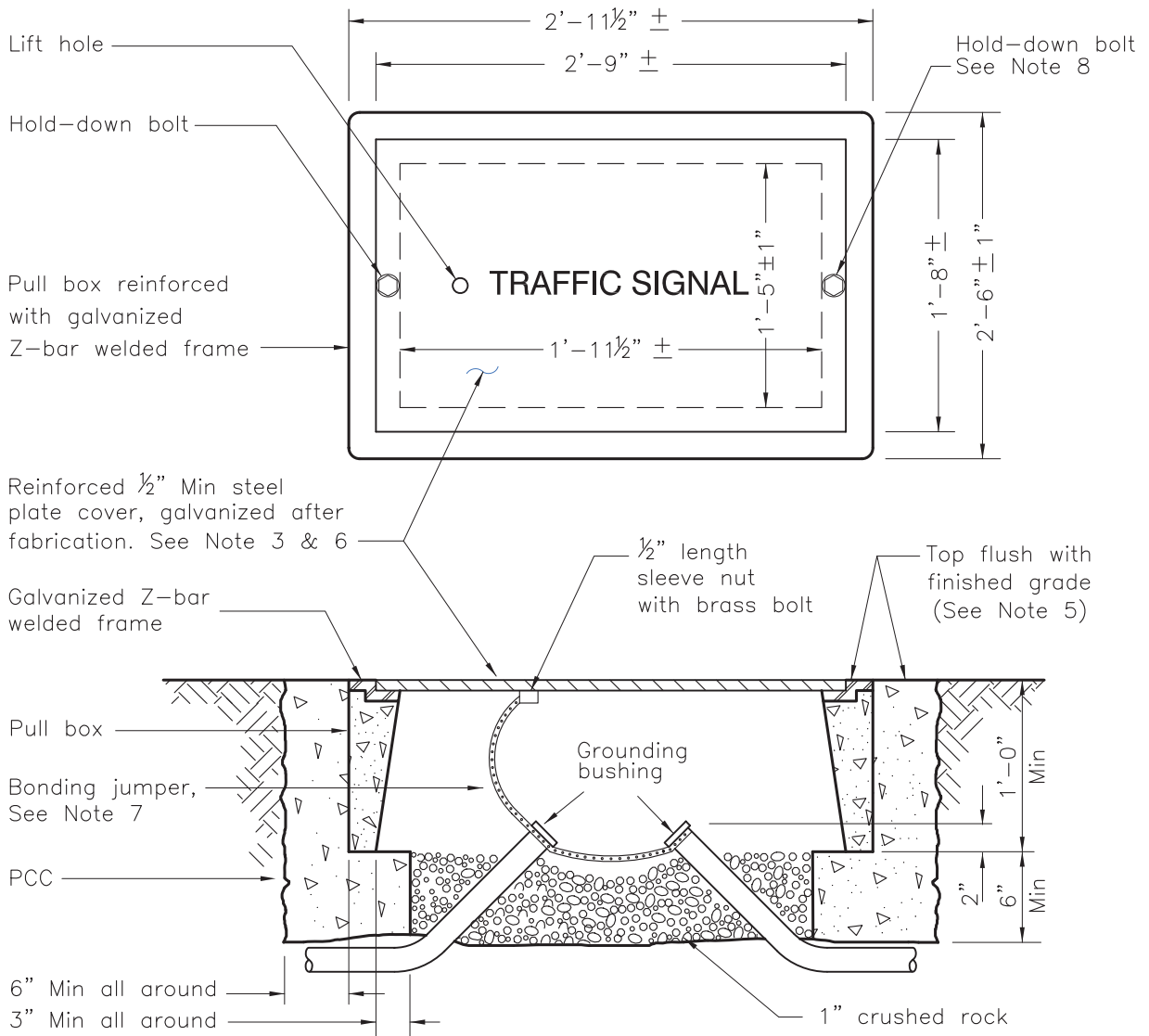

NOTES:

1. Traffic pullboxes in driveways, alleys and locations with vehicular traffic shall be metal covered per this standard.
2. Pullbox details not shown on this plan shall conform to Caltrans Standard Plan ES-8.
3. Traffic pullbox shall be provided with steel cover and special concrete footing. Steel cover shall have embossed non-skid pattern.
4. Galvanized conduits must be bonded with copper ground strap around the neck of each conduit. PVC conduits must have their #8 green ground wires spliced together.
5. Top of pull boxes shall be flush with surrounding grade or top of adjacent curb, except that in unpaved areas where pull box is not immediately adjacent to and protected by a concrete foundation, pole or other protective construction, the box shall be placed with its top 1 1/4" above surrounding grade. Where practicable, pull boxes shown in the vicinity of curbs shall be placed adjacent to the back of curb, and pull boxes shown adjacent to standards shall be placed on side of foundation facing away from traffic, unless otherwise noted. When pull box is installed in sidewalk area, the depth of the pull box shall be adjusted so that the top of the pull box is flush with the sidewalk.
6. Pull box cover shall be marked as "TRAFFIC SIGNAL".
7. Bonding jumper for metal covers shall be flat braided strap, 2' long minimum, Panduit Part # BS202446EU or equivalent.
8. Hold-down bolt shall be 5/8" and coarse threaded.

DWN	MT	05-10-07	Title METAL COVER TRAFFIC PULL BOX [CALTRANS PULLBOX No.6 (T)]
CKD			
T. E.	JV	2-11-08	
Sr. T. E.	JW	2-13-08	CITY OF LOS ANGELES DEPARTMENT OF TRANSPORTATION
Pr. T. E.	SS	2-13-08	
Approved		June 26, 2008	Drawing No.
<i>John E. Fisher</i>			S-78.5.2
for Rita L. Robinson, General Manager			

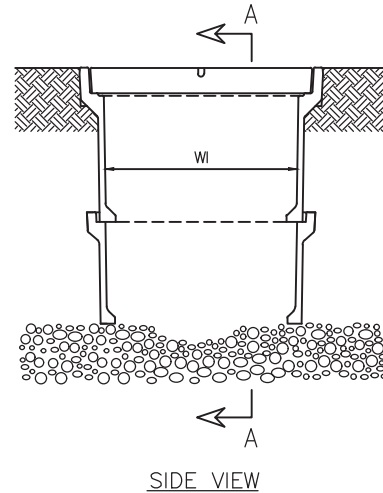
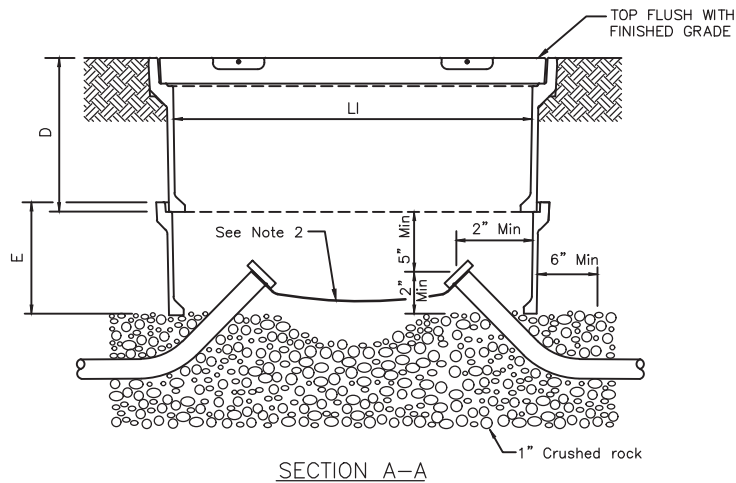

INSTALLATION DETAILS

DETAIL A

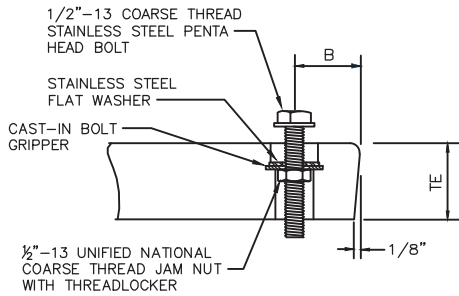
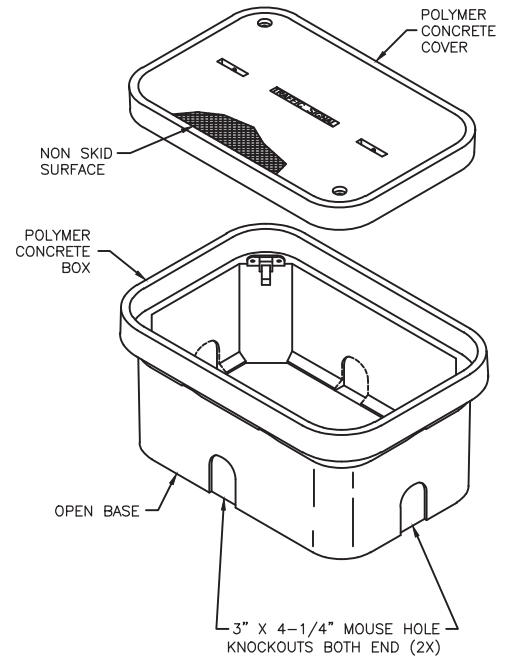
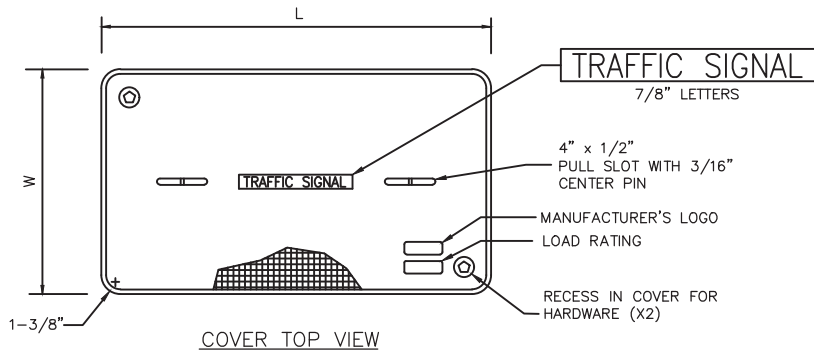

TYPICAL COVER CAPTIVE BOLT
(OR SIMILAR)

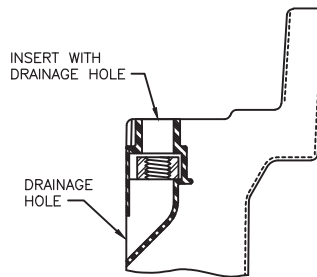

TYPICAL THREADED INSERT
(OR SIMILAR)

NOMINAL DIMENSIONS TABLE								
PULL BOX					COVER			
PULL BOX TYPE	MINIMUM DEPTH BOX (D)	MINIMUM DEPTH EXTENSION (E)	LI Min	WI Min	TE	B	L	W
PB2	12"	10"	1'-8"	11"	2"	1 3/4"	1'-11 1/4"	1'-1 3/4"
PB3	12"	10"	2'-4 1/4"	1'-3 1/4"	2"	2"	2'-6 1/2"	1'-5 1/2"

Notes:

- Refer to Dept. of Public Works Standard Drawing # L-201-1 for additional details and requirements.
- Galvanized conduits in pull box must be bonded with copper ground strap around the neck of each conduit. PVC conduits must have their #8 green ground wires spliced together.
- Pull box to be used in non-traffic areas; may be stacked no more than two deep.
- Stencil TRAFFIC SIGNAL in 1" lettering on backside of cover and inside of box.

DWN	SB	02-22-23	Title COMPOSITE PULL BOX, TYPES PB-2 & PB-3	
CKD				
T. E.	SB	02-22-23		
Sr. T. E.	JV	02-22-23		
Pr. T. E.			CITY OF LOS ANGELES DEPARTMENT OF TRANSPORTATION	
Approved		February 28, 2023		Drawing No.
 for Connie Llanos, Interim General Manager			S-78.5.3	

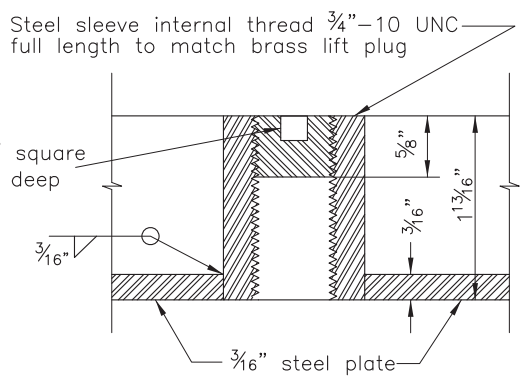
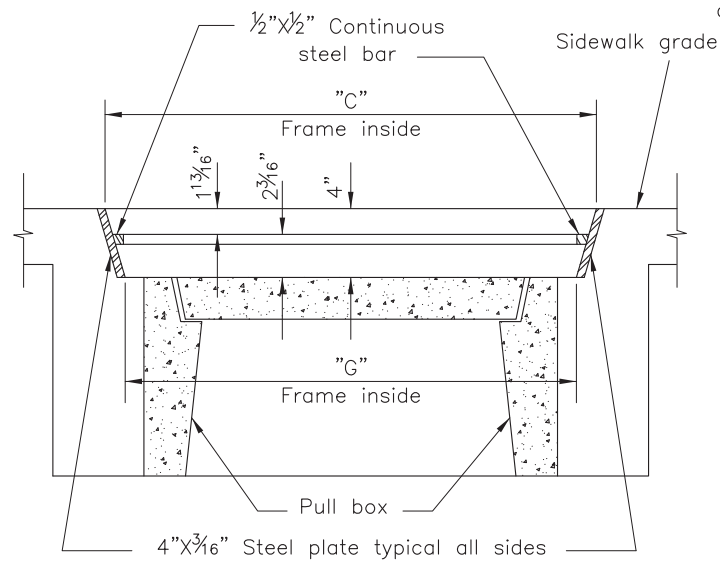
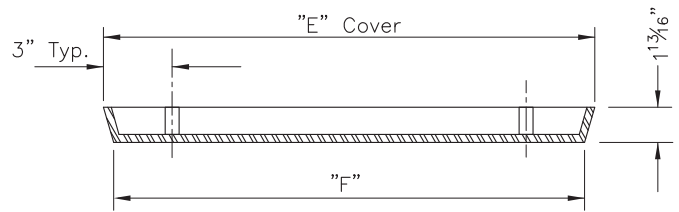
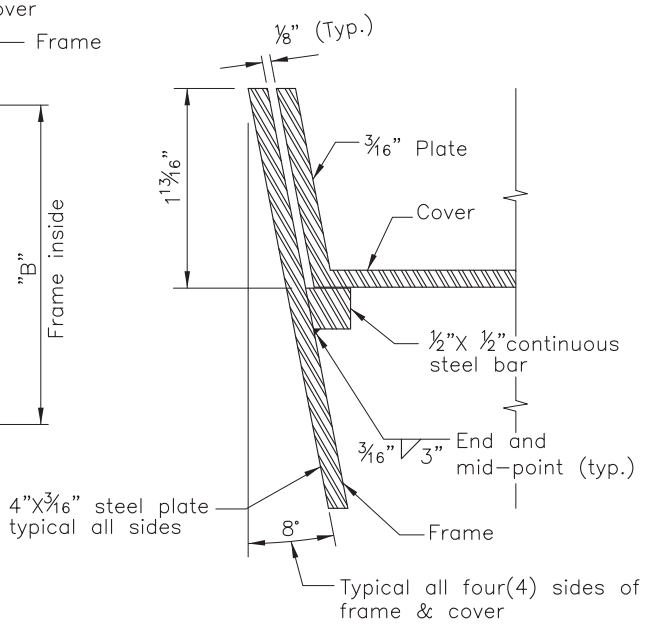
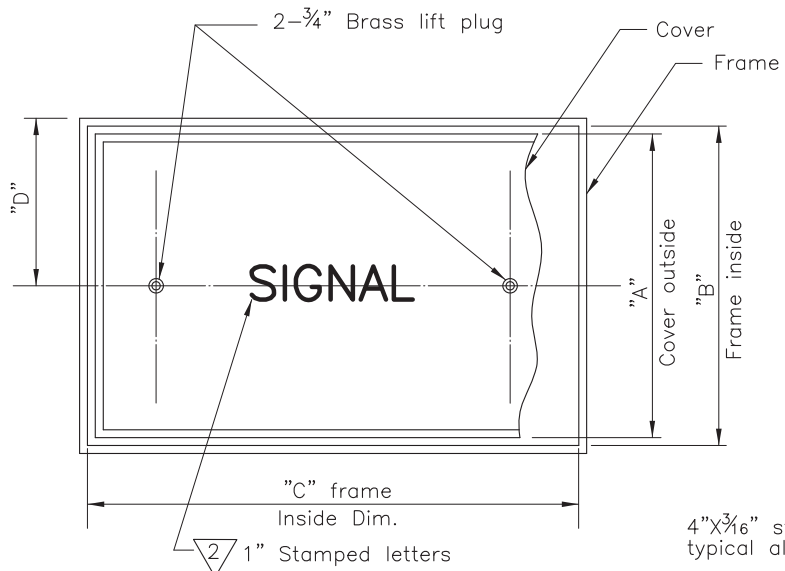

Notes:

1. All metal surfaces for special frame and cover shall have a galvanized finish.
2. All welding, machining and drilling shall be done before galvanizing.
3. Plug threads must be greased thoroughly prior to installation.

	"A"	"B"	"C"	"D"	"E"	"F"	"G"
For Type 2 Pullbox	18 3/4"	19"	29"	9 1/2"	28 3/4"	28 1/4"	27 7/8"
For Type 3 Pullbox	25 3/4"	26"	38"	13"	37 3/4"	37 1/4"	36 7/8"

1

1
2

Drawn By	BS	7-27-83	Title	SPECIAL COVER FOR PULL BOX
Checked By	SB	8-8-83		
Supervised By	RO	8-18-83		
Reviewed By	JAC	8-19-83	CITY OF LOS ANGELES DEPARTMENT OF TRANSPORTATION Donald R. Howery, General Manager	
Revisions			Approved August 19, 1983	DRAWING NO. S-78.8
Revised RC JK	JAC	8-8-84		
Reviewed By	TLJ	6-26-02	Donald Howery General Manager	

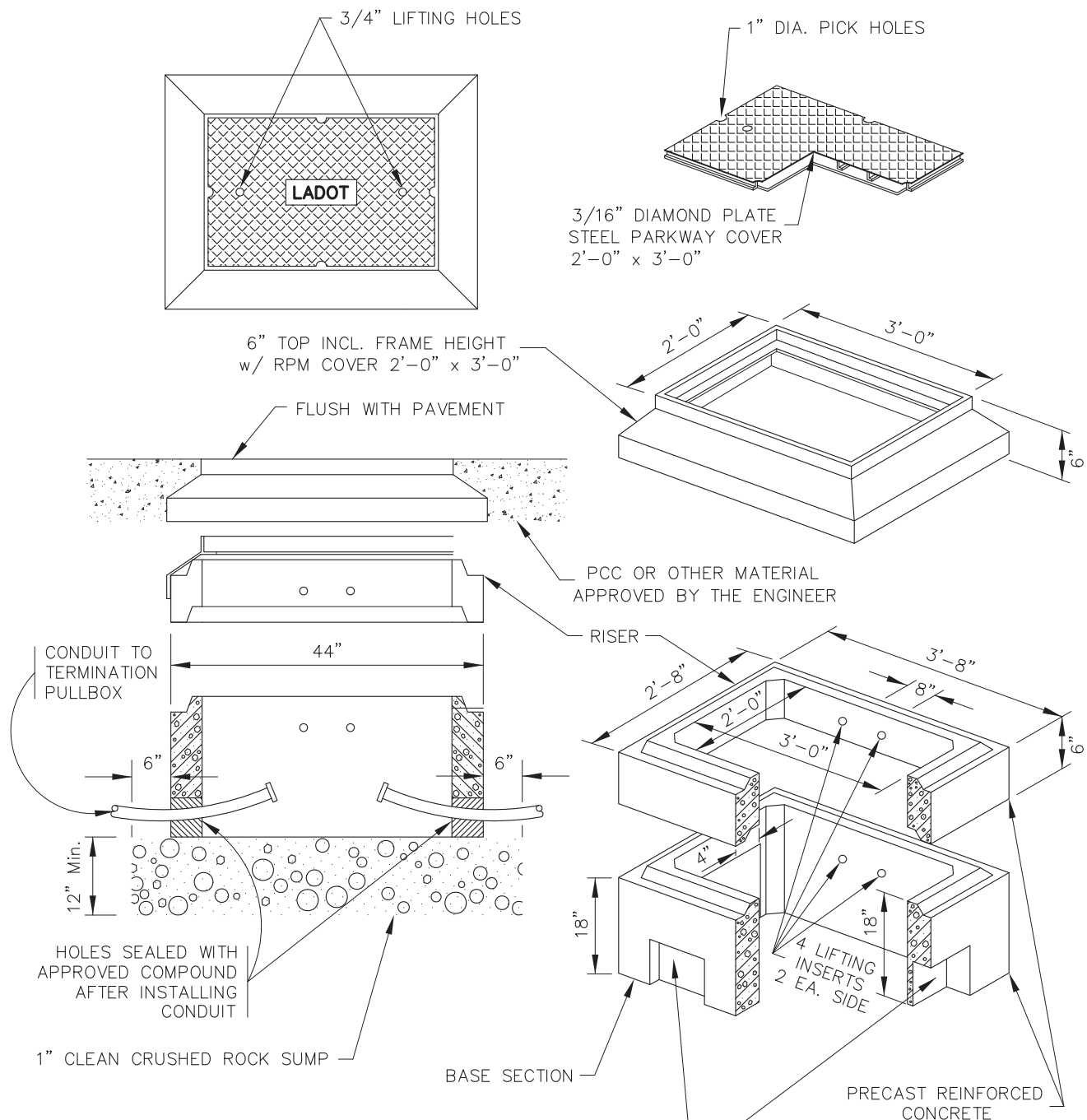

NOTES:

1. LIFTING RINGS AND BOLTS SHALL BE PROVIDED.
2. PARKWAY COVER SHALL BE 3/16" SAFETY PLATE, 5/16" SAFETY PLATE FOR TRAFFIC COVER.
3. ALL METAL SURFACES FOR SPECIAL FRAME AND COVER SHALL HAVE A GALVANIZED FINISH.
4. ALL WELDING, MACHINING AND DRILLING SHALL BE DONE BEFORE GALVANIZING.
5. PLUG THREADS MUST BE GREASED THOROUGHLY PRIOR TO INSTALLATION.

4" x 8" KNOCKOUTS
2 PICS. EA SIDE WALL
8" x 11" KNOCKOUTS
2 PICS. EA END WALL

DWN			Title
CKD	JEM	2-5-08	FIBER OPTIC SPLICE BOX I 1/1
T. E.			CITY OF LOS ANGELES DEPARTMENT OF TRANSPORTATION
Sr. T. E.	JEM	2-13-08	
Pr. T. E.	SFS	2-13-08	
Approved		June 26, 2008	Drawing No.
<i>John E. Fisher</i>			S-79.02A
for Rita L. Robinson, General Manager			

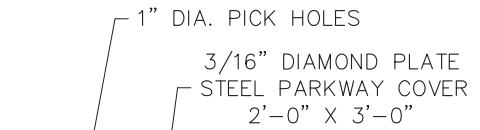
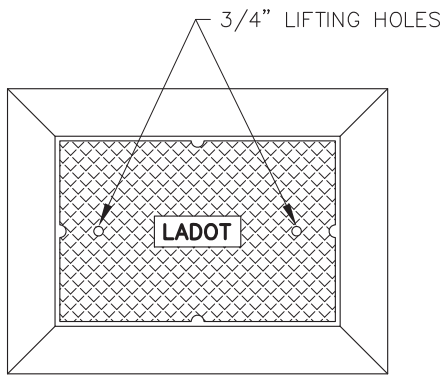

1-1/2" x 1-1/2" x 1/4"
ANGLE ALL AROUND

U-SLOT IN PLATE & ANGLE
FOR BOLT DOWN TO FRAME

6" TOP INCL. FRAME HEIGHT
w/ RPM COVER 2'-0" x 3'-0"

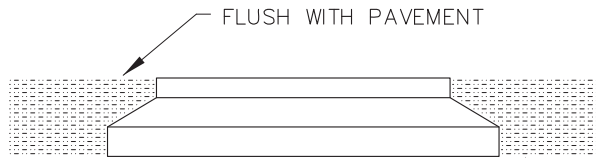
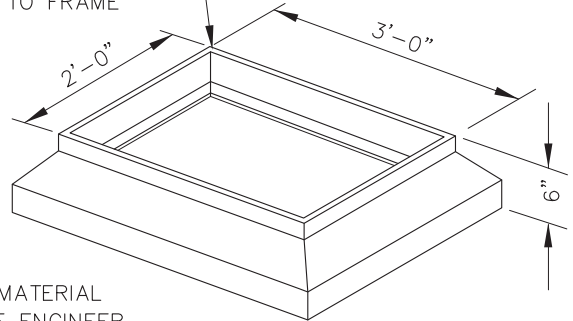

PCC OR OTHER MATERIAL
APPROVED BY THE ENGINEER

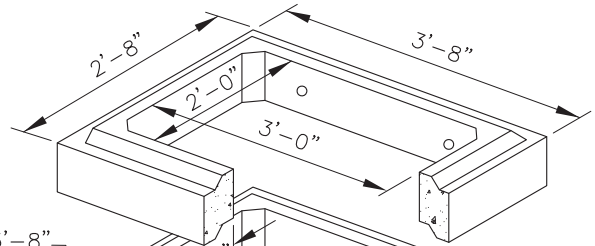
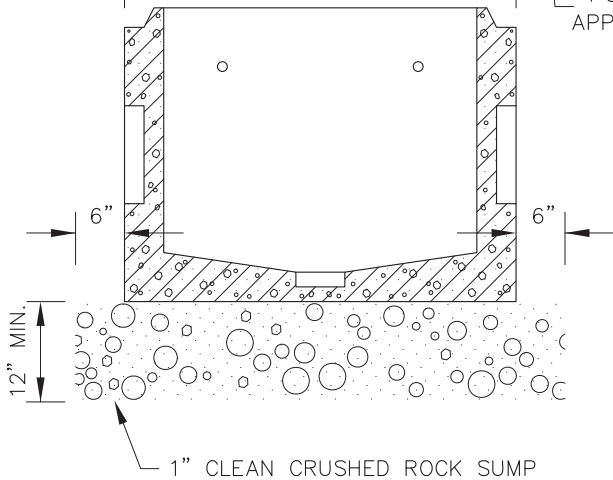

2'-8" x 3'-8"

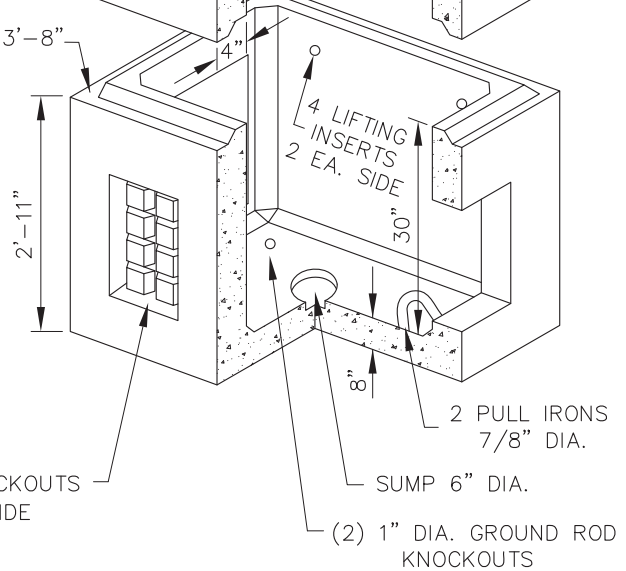

8" x 16" KNOCKOUTS
2 EACH SIDE

NOTES:

1. TWO 1" DIA. GROUNDING ROD KNOCKOUTS SHALL BE PROVIDED.
2. LIFTING RINGS AND BOLTS SHALL BE PROVIDED.
3. PARKWAY COVER SHALL BE 3/16" SAFETY PLATE, 5/16" SAFETY PLATE FOR TRAFFIC COVER.
4. ALL METAL SURFACES FOR SPECIAL FRAME AND COVER SHALL HAVE A GALVANIZED FINISH.
5. ALL WELDING, MACHINING AND DRILLING SHALL BE DONE BEFORE GALVANIZING.
6. PLUG THREADS MUST BE GREASED THOROUGHLY PRIOR TO INSTALLATION.

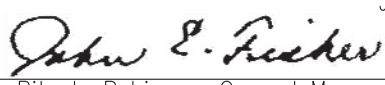
DWN			Title
CKD	JEM	2-5-08	FIBER OPTIC SPLICE BOX II 1/1
T. E.			
Sr. T. E.	JEM	2-13-08	CITY OF LOS ANGELES
Pr. T. E.	SFS	2-13-08	DEPARTMENT OF TRANSPORTATION
Approved	June 26, 2008		Drawing No.
 for Rita L. Robinson, General Manager			S-79.02B

Notes:

1. Type F-1 -2" nominal size conduit, unless otherwise specified.
2. Type F-8 & Type F-8A -3" nominal size conduit, unless otherwise specified.
3. Unless otherwise specified, in unpaved areas a 36" X 24" X 4" slab shall be provided for each door opening in the case of a model 336 cabinet.
4. On Type F-8 & Type F-8A, ground rod shall be installed in controller pullbox.

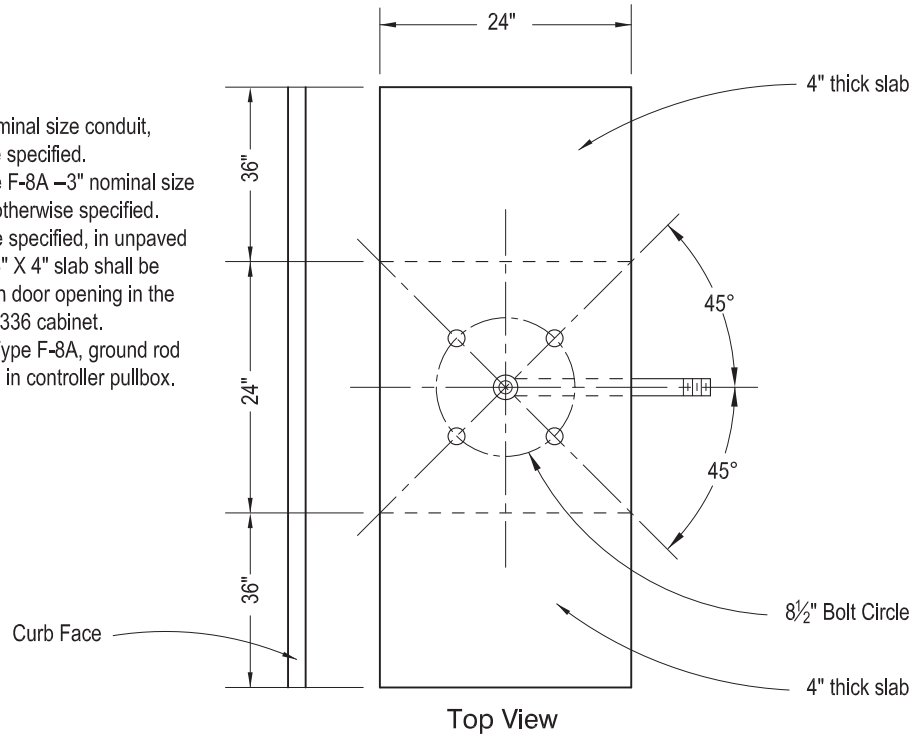

0.50" NC square nut holder with fastener for grounding welded to interior of pole shaft at 180° from hand hole rim

#8 Green bonding wire

Anchor bolt-thread top 8" and galvanize 12" (2 nuts and 2 washers required per bolt), total 4

Base plate 10" X 10" X 3/4"

2" Min. to 3" Max. Mortar

Curb Face

After plumbing standard, place mortar all around bolts. Finish with slope ranging from 45° to 90° including drain holes

1"Ø X 3'-0" anchor bolts thread bottom 6", (2 nuts and 2 washers, total 4 required per bolt)

Anchor plate 10" X 10" X 3/4"

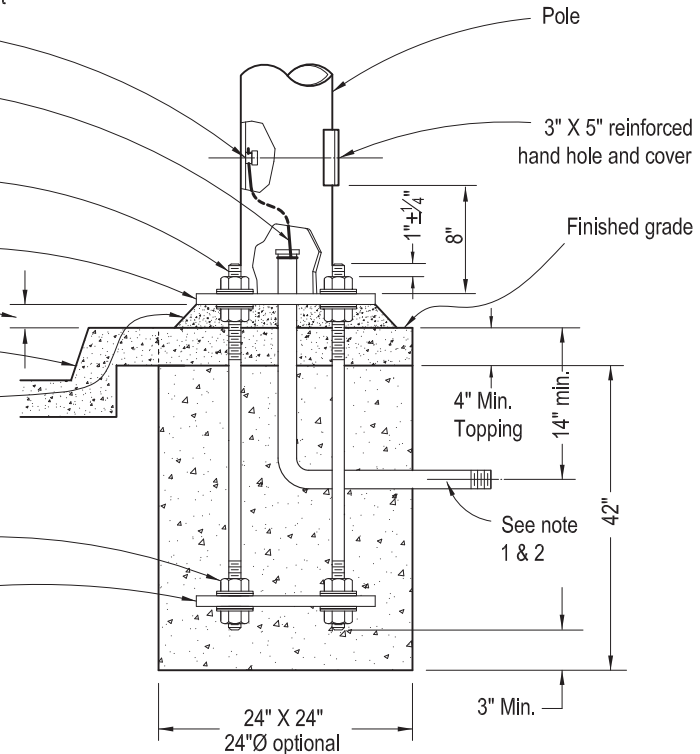

BUREAU OF ENGINEERING STRUCTURAL ENGINEERING DIVISION CITY ENGINEER: GARY LEE MOORE, PE, ENV SP	DWN	MT	9-30-15	Title	FOUNDATION TYPE F-1 & F-8	
	CKD					
	T. E.	JV	9-30-15			
STRUCTURAL DESIGN CHECKED BY: <u>PETER CHIU, SE</u> APPROVED BY: _____ DATE 1-26-16	Sr. T. E.	MA	10-1-15	CITY OF LOS ANGELES DEPARTMENT OF TRANSPORTATION		
SHAILESH PATEL, SE, DIVISION ENGINEER	Pr. T. E.	VJ	10-2-15			
Approved		Date 11-20-15		Drawing No.		S-52.1
				Seleta J. Reynolds, General Manager		

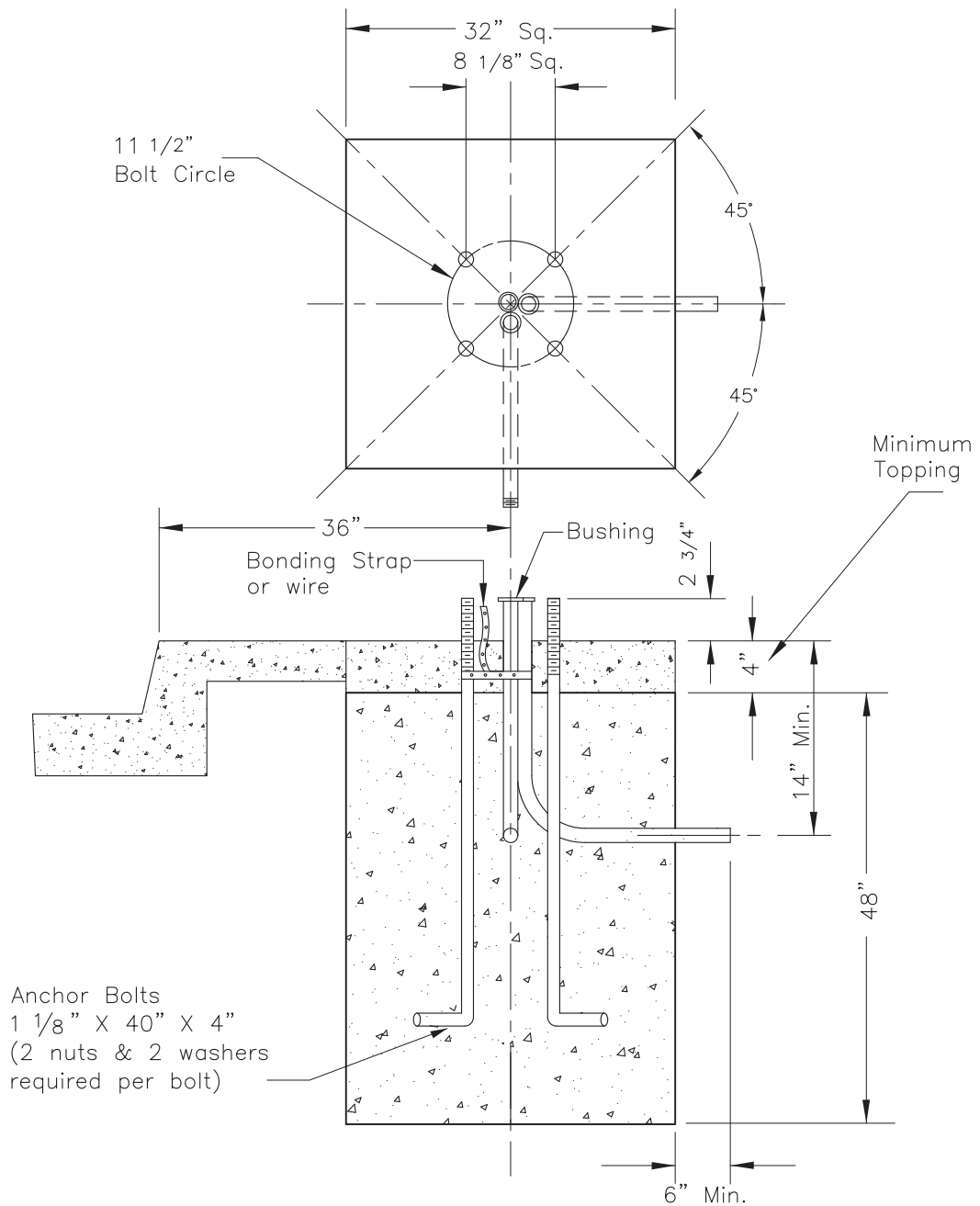

Anchor Bolts
 1 1/8" X 40" X 4"
 (2 nuts & 2 washers
 required per bolt)

Notes:

1. Use 1" galvanized conduit for street lighting and 2" schedule 80 PVC conduit for traffic signal unless otherwise specified.
2. Conduit stubs from foundation shall be in the direction of the nearest corresponding pullbox unless otherwise specified.
3. Topping shall be considered as a part of the foundation.

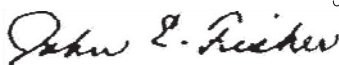
DWN	MT	03-30-04	Title	FOUNDATION, TYPE F-2 1/1
CKD				
T. E.	JV	6-1-06		
Sr. T. E.	JW	6-1-06		
Pr. T. E.	SS	6-2-06		
Approved			June 2, 2006	Drawing No.
 for Gloria J. Jeff, General Manager				S-52.2

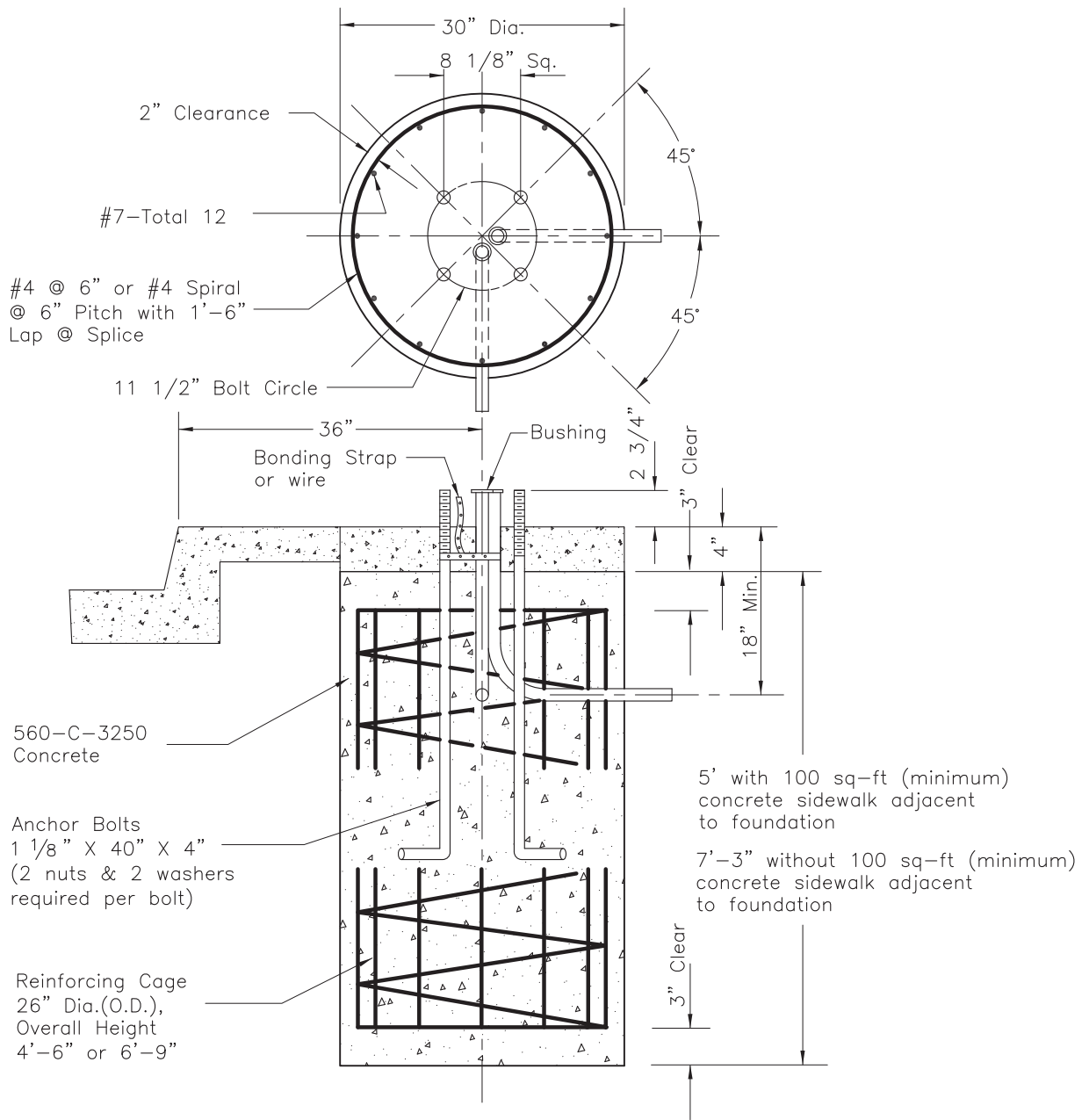

Notes:

1. Use 1" galvanized conduit for street lighting and 2" schedule 80 PVC conduit for traffic signal unless otherwise specified.
2. Conduit stubs from foundation shall be in the direction of the nearest corresponding pullbox unless otherwise specified.

DWN	MT	11-8-04	Title	CIDH FOUNDATION, TYPE F-2	1/1
CKD					
T. E.	JV	6-1-06	CITY OF LOS ANGELES DEPARTMENT OF TRANSPORTATION		
Sr. T. E.	JW	6-1-06			
Pr. T. E.	SS	6-2-06			
Approved			June 2, 2006	Drawing No.	
<i>John E. Fisher</i>					S-52.2.2
for Gloria J. Jeff, General Manager					

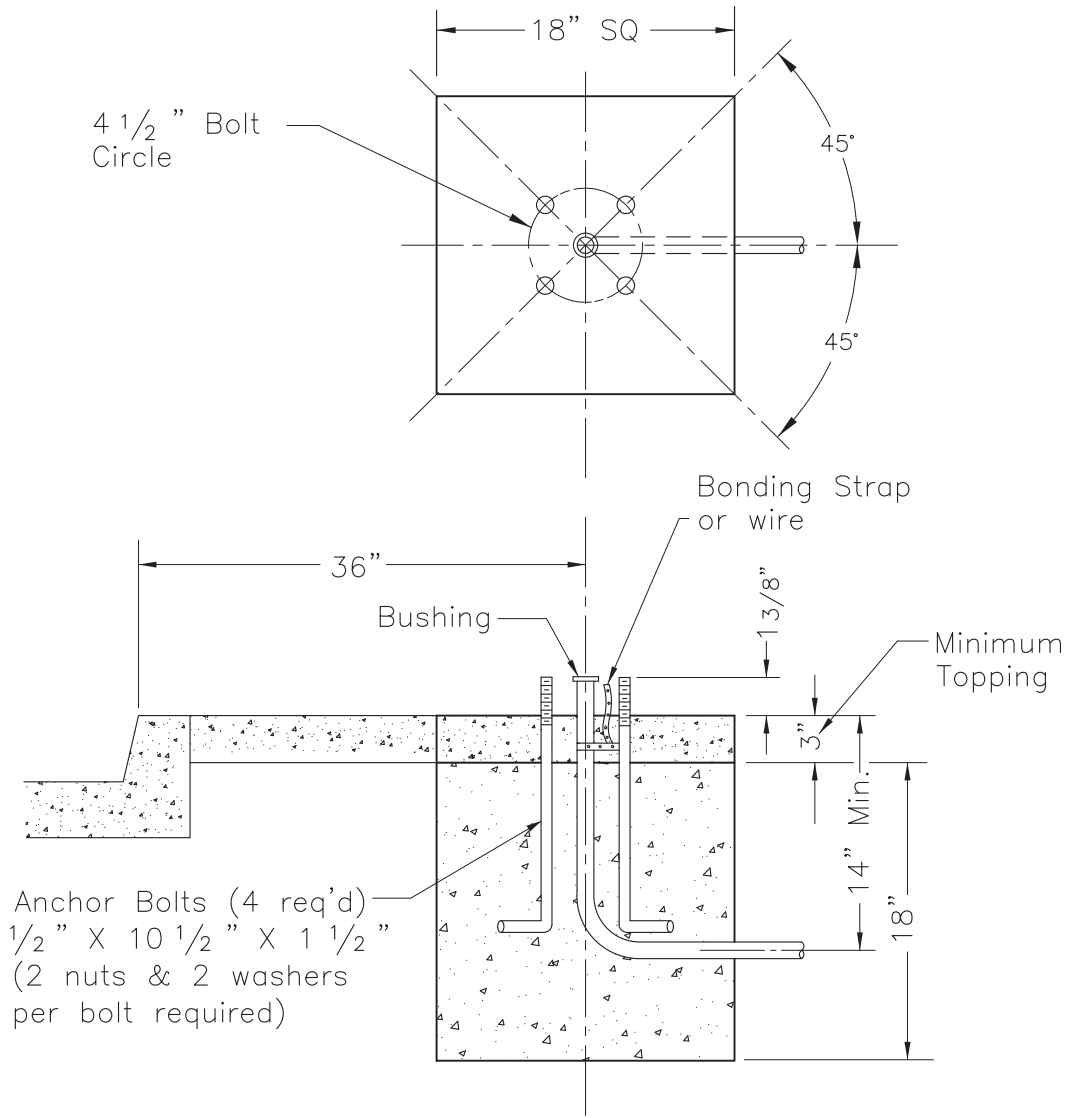

NOTES:

1. Conduit shall be 1" nominal size unless otherwise specified.
2. Topping shall be considered a part of the foundation.

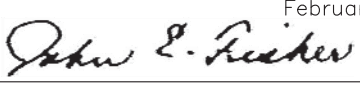
DWN	MT	03-05-04	Title
CKD			FOUNDATION, TYPE F-7 1/1
T. E.			
Sr. T. E.			
Pr. T. E.	TLJ	02-09-05	CITY OF LOS ANGELES DEPARTMENT OF TRANSPORTATION
Approved	February 25, 2005		Drawing No.
 for Wayne K. Tanda, General Manager			S-52.7

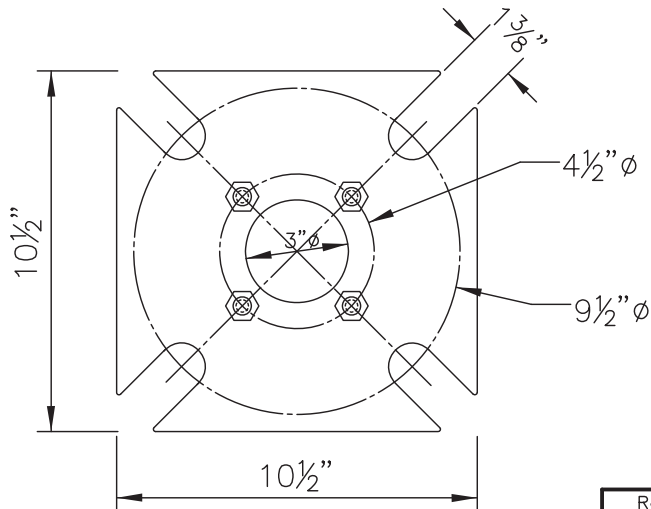
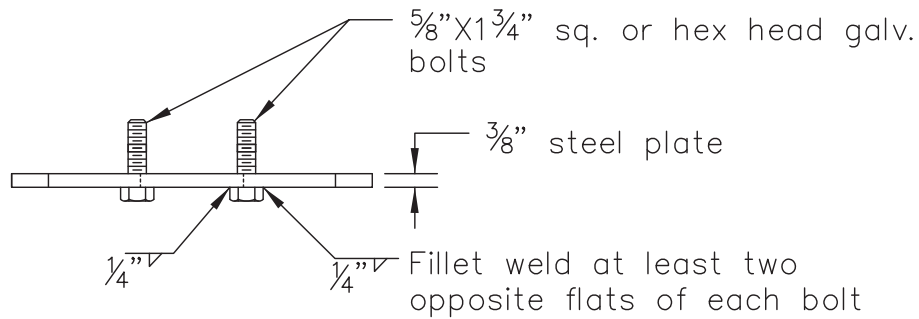
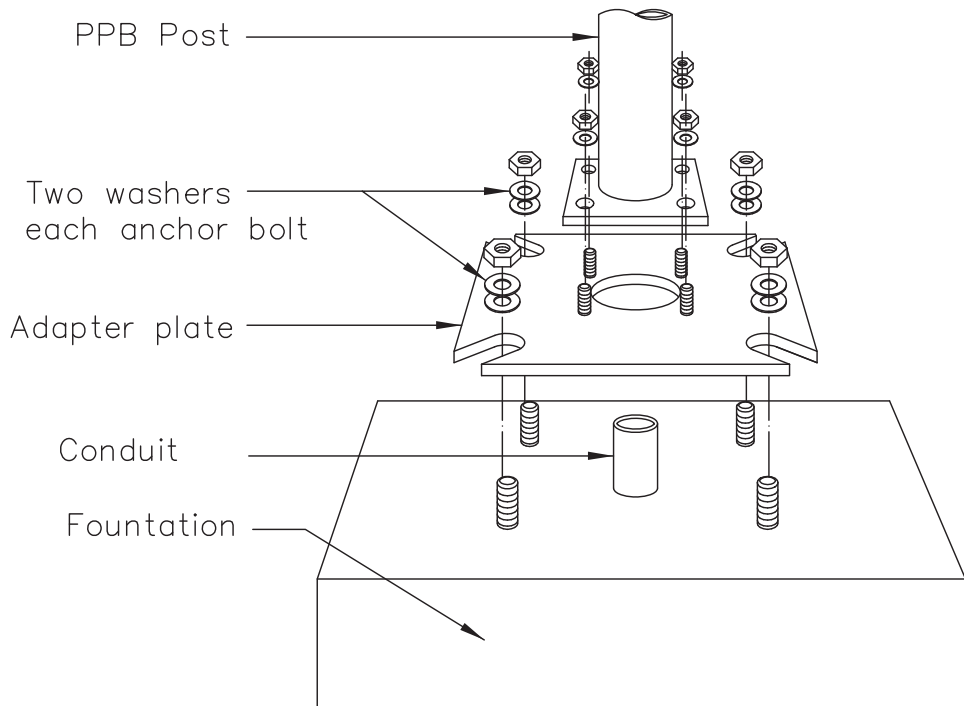

Note
 Base plate shall be hot dipped galvanized after machining in accordance with the latest edition of ASTM designation A-123

SPEC. NO. 92-056-01

Revisions	Title
	ADAPTER BASE PLATE (For F-1 to F-7 Foundation)
	CITY OF LOS ANGELES DEPARTMENT OF TRANSPORTATION Donald R. howery, General Manager
	Approved <u>May 27, 1971</u> B. Fredrickson For General Manager
	Drawing No. S-52.7.1

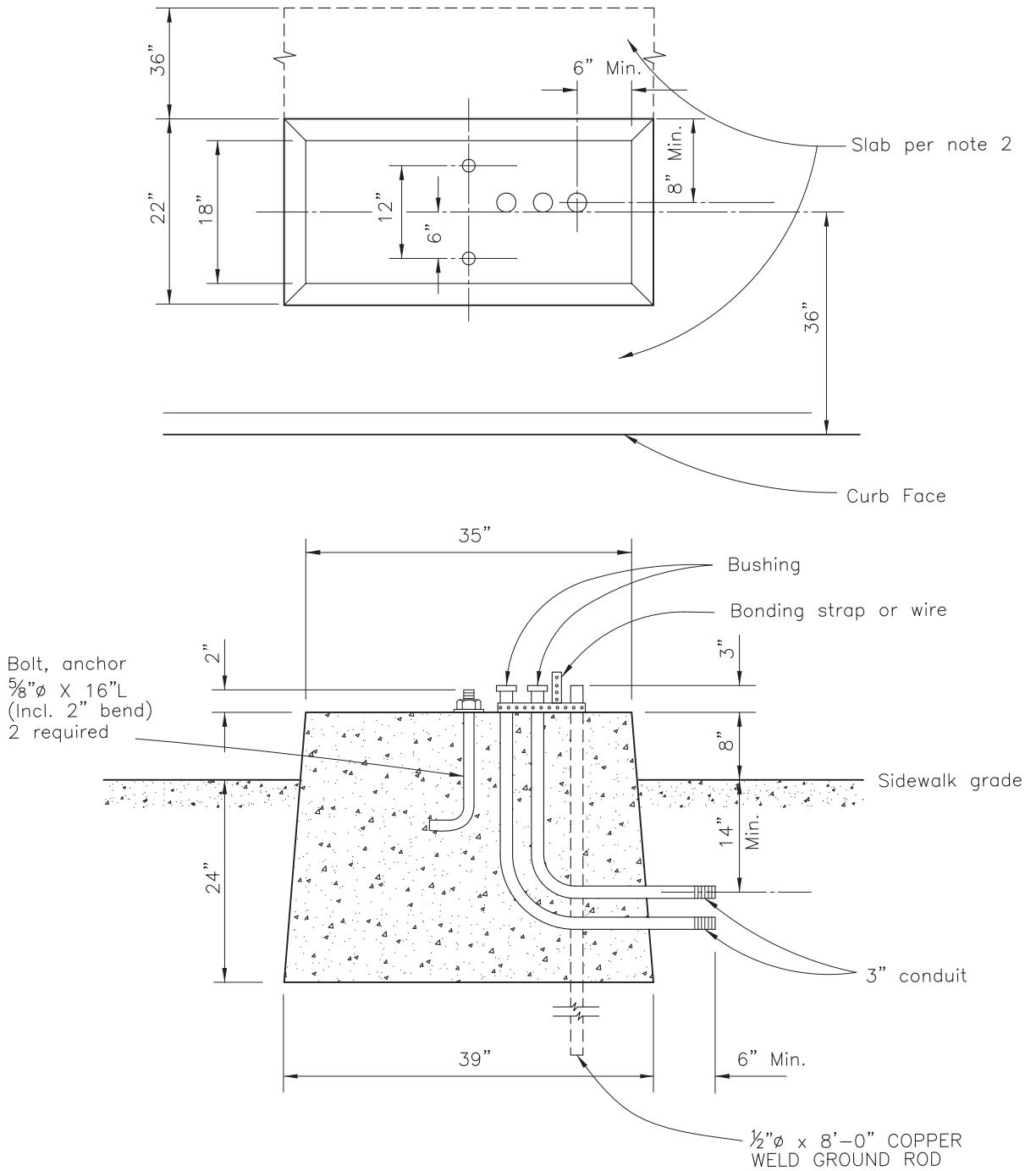

NOTES:

1. Conduit consists of (2) 3" nominal size unless otherwise specified.
2. Slab shall be constructed as per Standard Specification for Public Works Construction, section 302-6, latest edition.

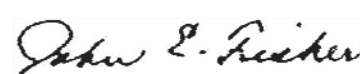
DWN	MT	5-07-08	Title	FOUNDATION, TYPE F-12A 1/1
CKD				
T. E.				
Sr. T. E.				
Pr. T. E.	SS	6-26-08	CITY OF LOS ANGELES DEPARTMENT OF TRANSPORTATION	
Approved			June 26, 2008	Drawing No.
 for Rita L. Robinson, General Manager			S-52.1.2B	

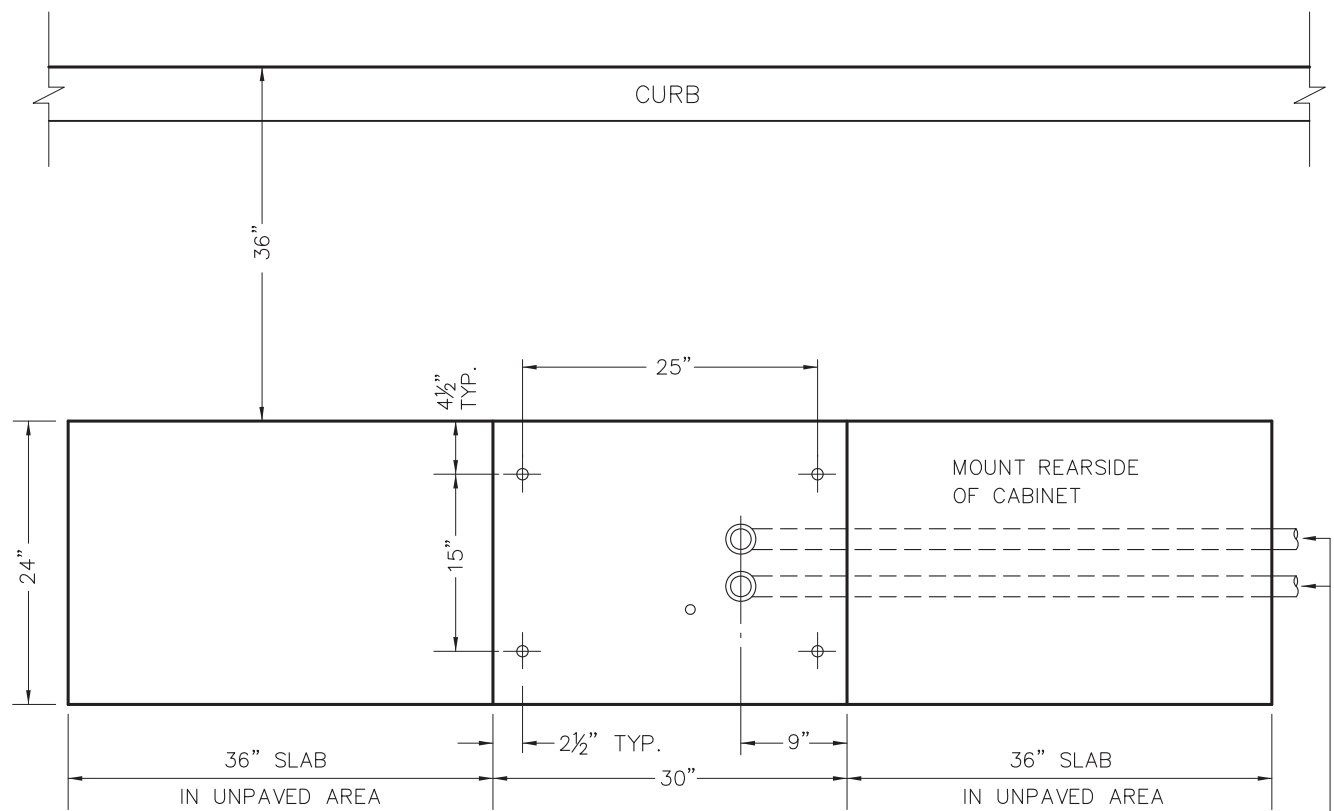

TOP VIEW

TO #3 PULLBOX

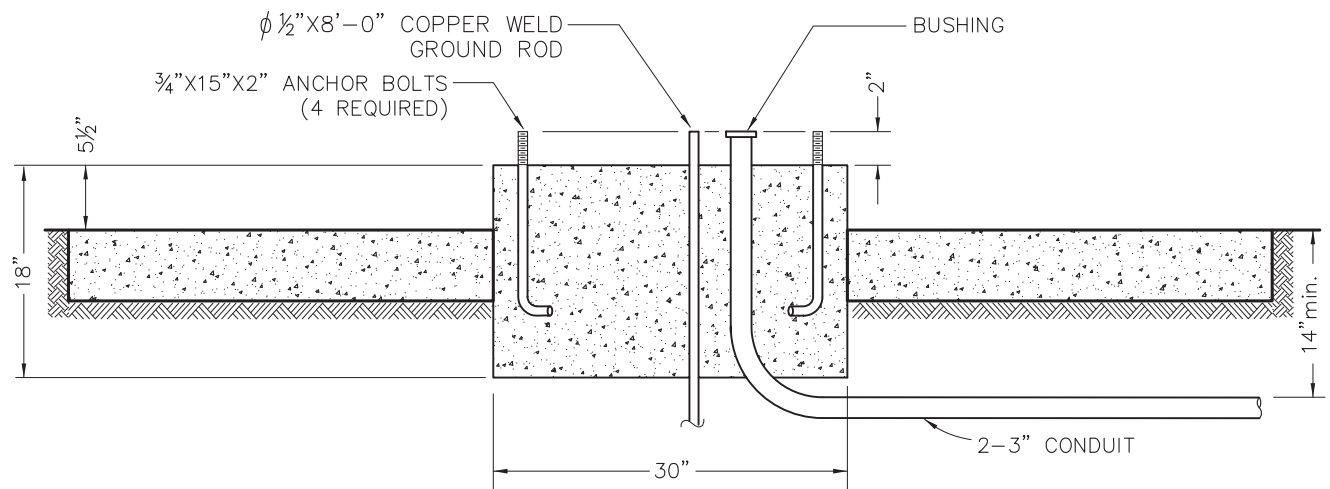

SIDE VIEW

NOTE:

1. NO PULLBOX TO BE LOCATED WITHIN THE FRONT OR REAR 24"X36" CONCRETE SLAB.
2. SEE STANDARD DRAWING NO. S-79.9B FOR GROUNDING DETAILS.

DWN	MT	11-8-11	Title
CKD			FOUNDATION, TYPE F-332 (1/1)
T. E.			
Sr. T. E.			
Pr. T. E.	SS	12-8-11	CITY OF LOS ANGELES DEPARTMENT OF TRANSPORTATION
Approved		<i>John E. Fisher</i>	12-8-11
		for Jaime de la Vega, General Manager	Drawing No.
			S-52.1.3

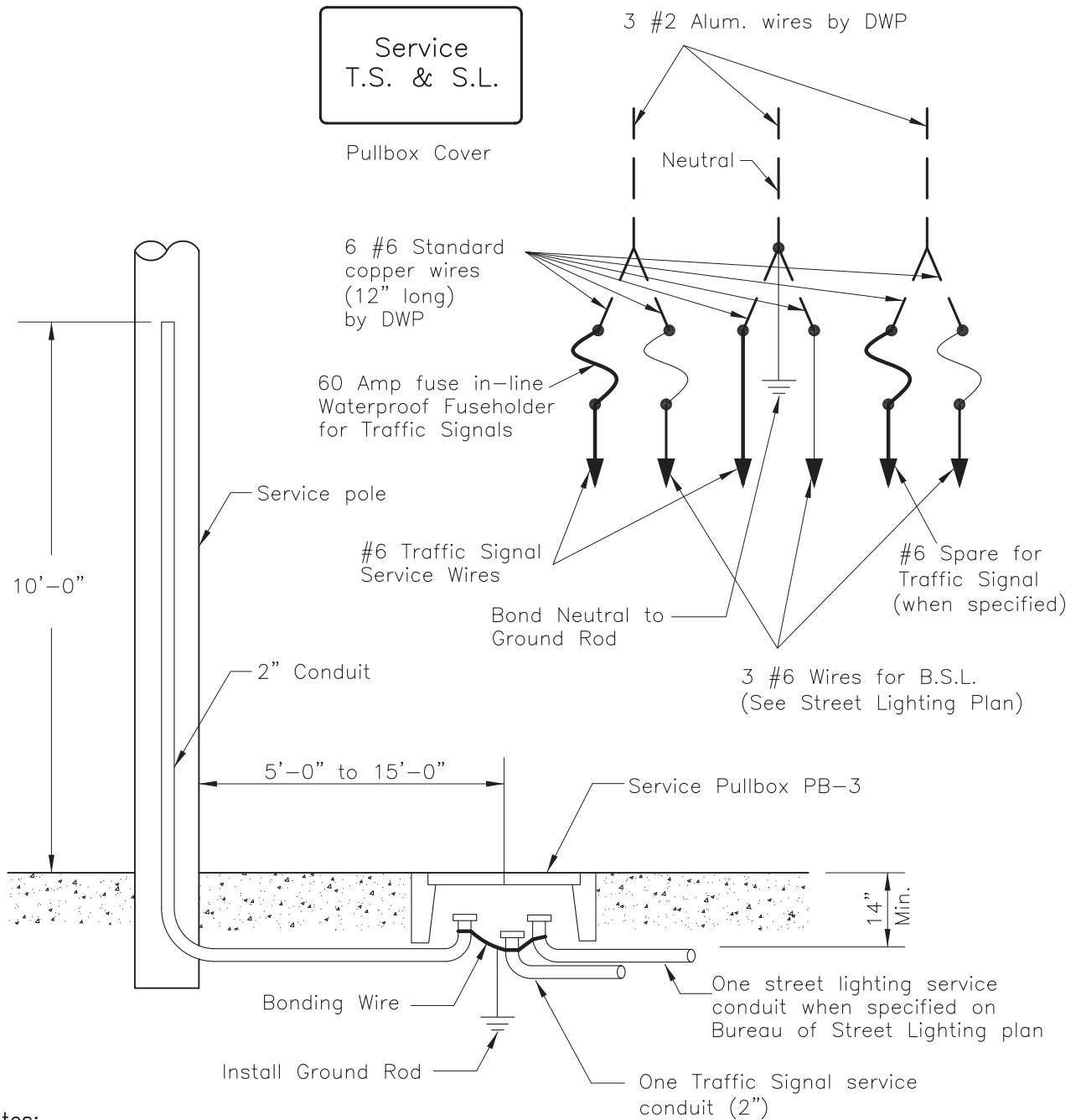

Notes:

1. Department of Water & Power to install 3 #2 stranded aluminum wires from service pole to pullbox. At the terminus of each #2 aluminum wire the Dept. of Water & Power to splice 2 #6 stranded copper wires, (12" long) using compression type connectors. The exposed ends of each copper wire shall be taped when not in use.
2. Install continuous and dedicated #6 green service ground conductor to controller cabinet.
3. See Standard Specifications for Public Works Construction, Sec. 307-2.8
4. See Standard Drawing S-79.9B for grounding details.

DWN	MT	9-14-11	Title	Over Head Service, Dept. of Water & Power	1/1
CKD	RSM	9-14-11			
T. E.			CITY OF LOS ANGELES DEPARTMENT OF TRANSPORTATION		
Sr. T. E.					
Pr. T. E.					
Approved		10-27-11	Drawing No.		
for 		Jaime de la Vega, General Manager		S-79.8	

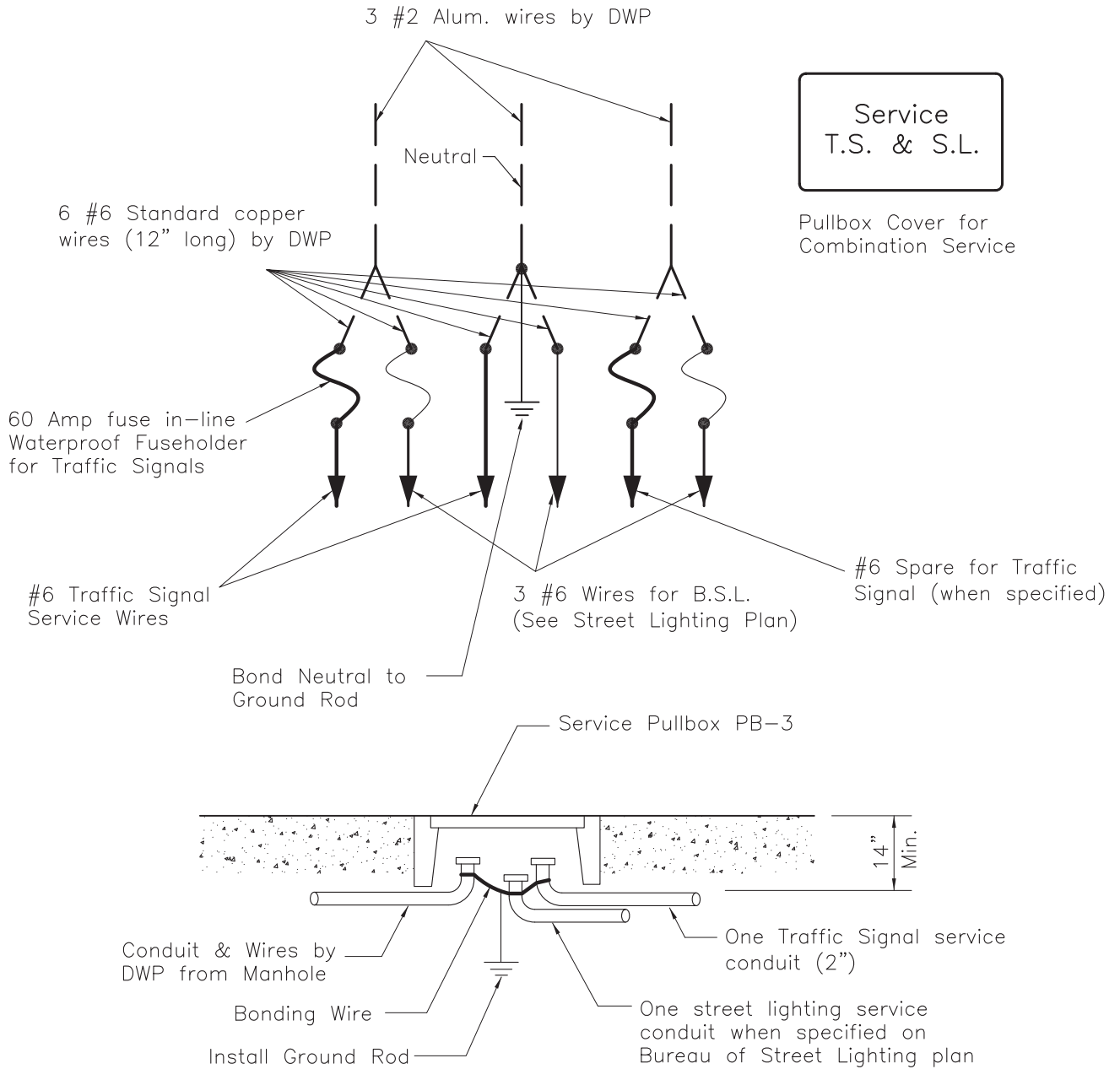

Notes:

1. Department of Water & Power to install 3 #2 stranded aluminum wires from service pole to pullbox. At the terminus of each #2 aluminum wire the Dept. of Water & Power to splice 2 #6 stranded copper wires, (12" long) using compression type connectors. The exposed ends of each copper wire shall be taped when not in use.
2. Install continuous and dedicated #6 green service ground conductor to controller cabinet.
3. See Standard Specifications for Public Works Construction, Sec. 307-2.8
4. See Standard Drawing S-79.9B for grounding details.

DWN	MT	8-17-11	Title	Under Ground Service, Dept. of Water & Power	1/1
CKD	RSM	9-14-11			
T. E.			CITY OF LOS ANGELES DEPARTMENT OF TRANSPORTATION		
Sr. T. E.					
Pr. T. E.					
Approved				10-27-11	Drawing No.
for		Jaime de la Vega, General Manager		S-79.9	

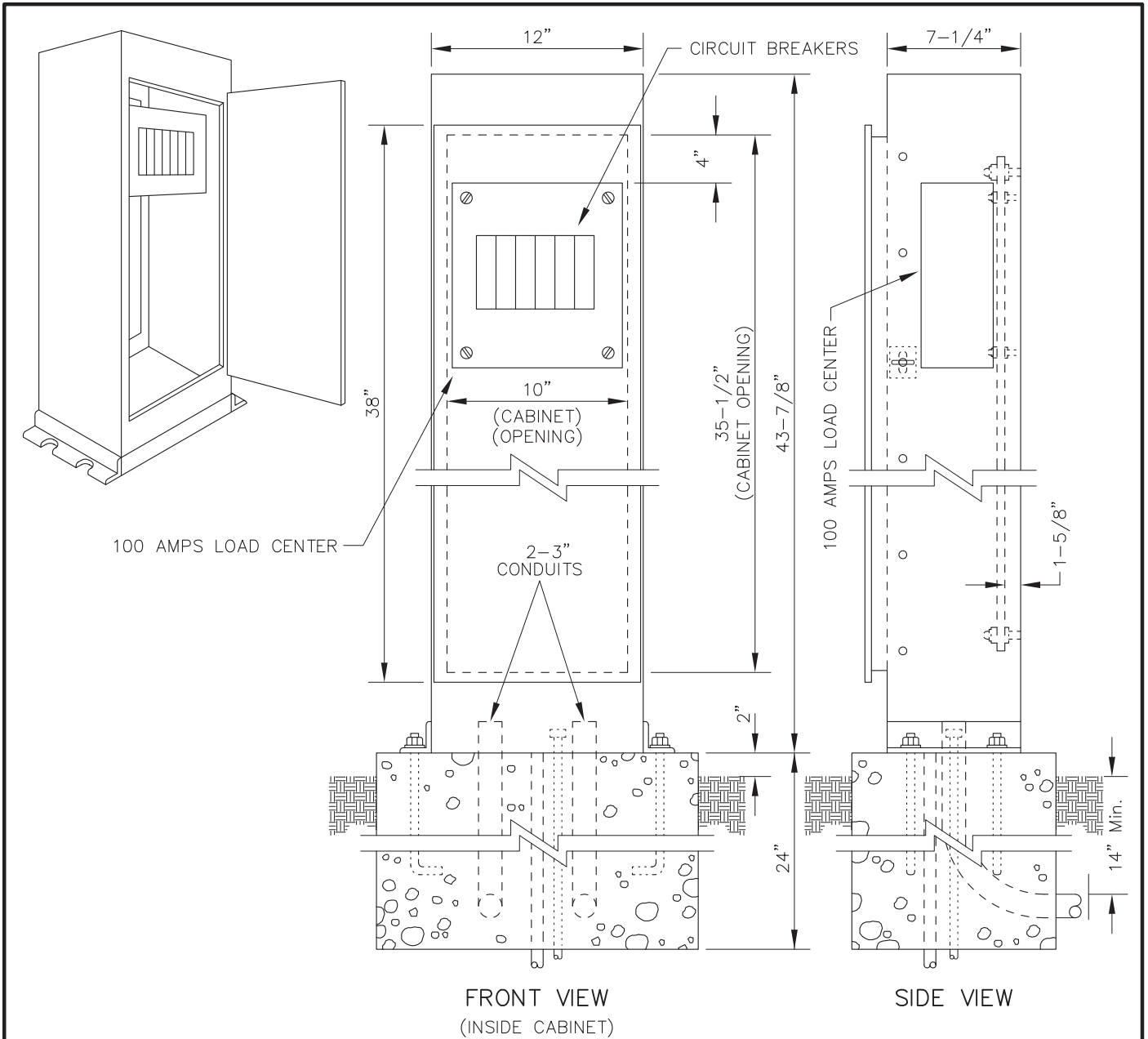

NOTES:

- FOR CABINET AND FOUNDATION DETAIL SEE CITY OF LOS ANGELES DEPARTMENT OF TRANSPORTATION STANDARD DRAWING NO.S-75.0C.
- SERVICE DISTRIBUTION CABINET SHALL HAVE INSTALLED ON ITS BACKPANEL A 100-AMPS LOADCENTER EQUIVALENT TO SQUARE D CAT. NO.Q06-12L100.
- CIRCUIT BREAKERS SHALL BE PROVIDED AND INSTALLED AS FOLLOWS:

1EA	2 POLE	50A
1EA	1 POLE	50A
1EA	1 POLE	30A
2EA	1 POLE	20A

Drawn By	LAR	09-19-91	Title TYPE II SERVICE DISTRIBUTION CABINET	
Checked By	ID	09-19-91		
Supervised By	VJ	09-19-91		
Reviewed By	AN	09-19-91		
Revisions			CITY OF LOS ANGELES DEPARTMENT OF TRANSPORTATION S. E. ROWE, General Manager	DRAWING NO. S-79.9A
Show Found. 2" Above Surface & Del. PVC	JEM	02-27-92		
			Approved S. E. Rowe General Manager	

PVC Conduit System

* Note:
Use a ground rod wire clamp
for each wire (Acorn)

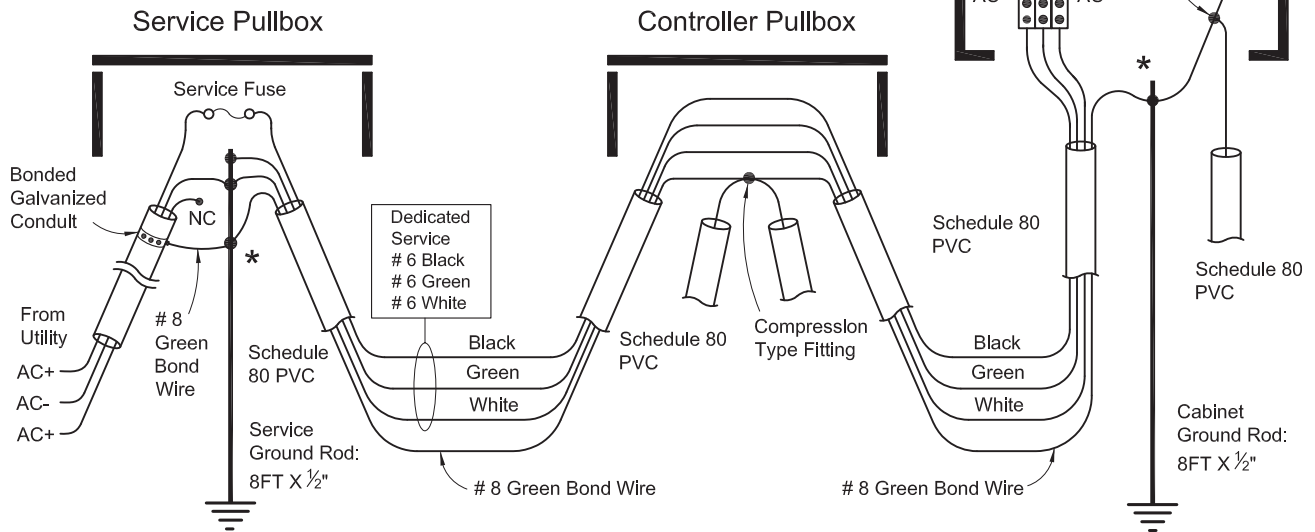

Galvanized Conduit System

* Note:
Use a ground rod wire clamp
for each wire (Acorn)

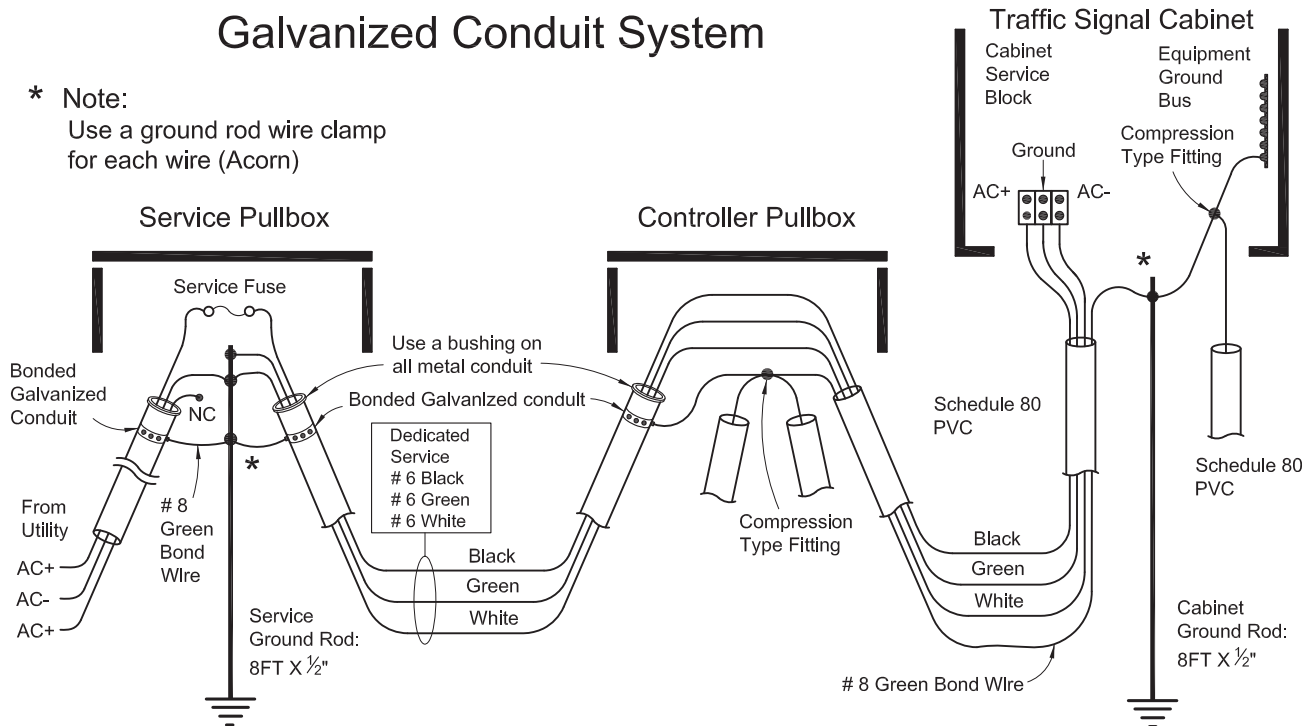

DWN	MT	8-17-11	Title	SERVICE GROUNDING CONDUIT SYSTEM	1/1
CKD	RL	8-17-11			
T. E.			CITY OF LOS ANGELES DEPARTMENT OF TRANSPORTATION		
Sr. T. E.					
Pr. T. E.	SS	9-9-11	Approved <i>John E. Fisher</i> September 9, 2011 for Jaime de la Vega, General Manager		

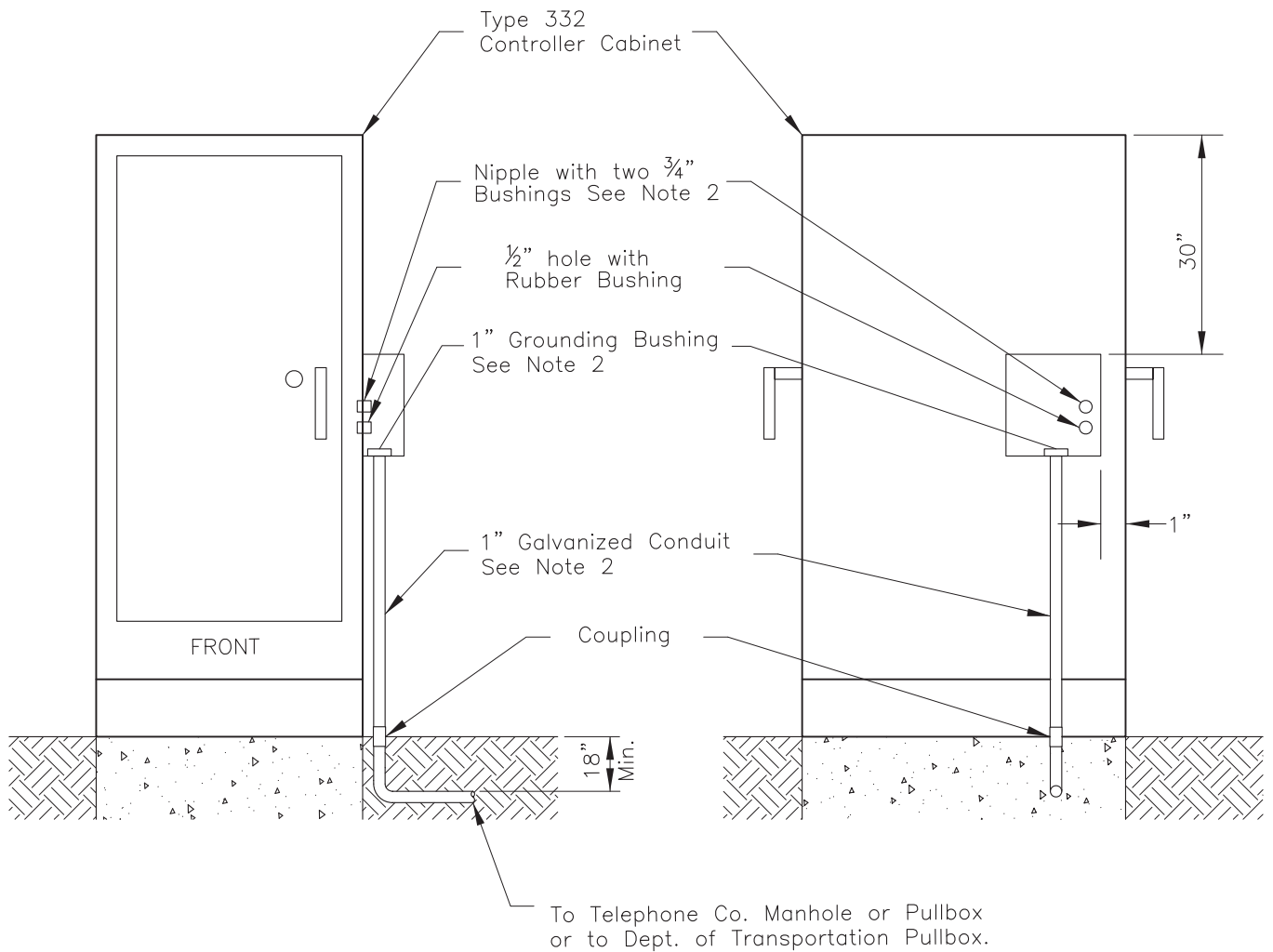

Notes:

1. Raintight box with three knockouts in bottom for $\frac{3}{4}$, 1, $1\frac{1}{4}$ or $1\frac{1}{2}$ inch conduit, U.L. approved; 10"W X 12"H X 4"D. Box to be galvanized ASTM Spec. A-525; Similar to circle A-W catalog number 10124 RTSC.
2. Install one nipple with two $\frac{3}{4}$ " bushings for each 1" Galvanized conduit installed as shown on plans.
3. Raintight box shall be drilled or otherwise configured to accept a padlock.

Drawn By	RM	12-1-89	Title Service, Telephone ATSAC 332 Cabinet
Checked By	JEM	12-12-89	
Supervised By	AN	12-18-89	
Reviewed By			
Revisions			CITY OF LOS ANGELES DEPARTMENT OF TRANSPORTATION S. E. Rowe, General Manager
			Approved 12-19-89
			S. E. Rowe General Manager
			DRAWING NO. S-79.3A

Specification

Design:

Design loading
Wind loading 20 psf

Design Stresses:

Concrete: $n=10$ — $\left\{ \begin{array}{l} f_c = 3,000 \text{ psi} \\ f_s = 20,000 \text{ psi} \end{array} \right.$
 Reinforcing Steel — $\left\{ \begin{array}{l} f_c = 1,200 \text{ psi} \\ f_s = 18,000 \text{ psi} \end{array} \right.$
 Structural steel — $\left\{ \begin{array}{l} f_b = 18,000 \text{ psi} \\ f_s = 3,000 \text{ psi} \end{array} \right.$
 Soil Bearing Pressure —

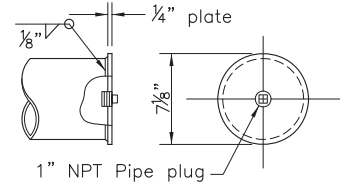

Detail "B"

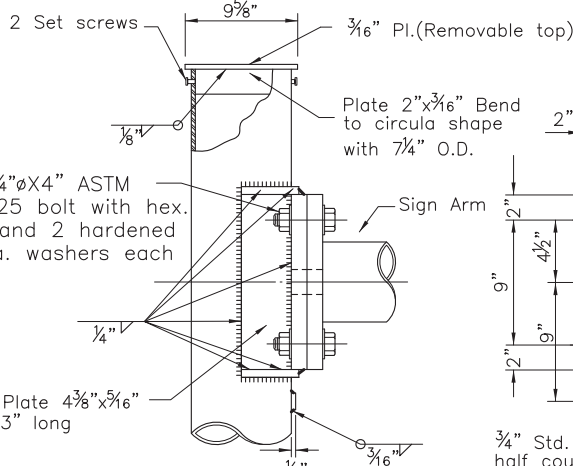
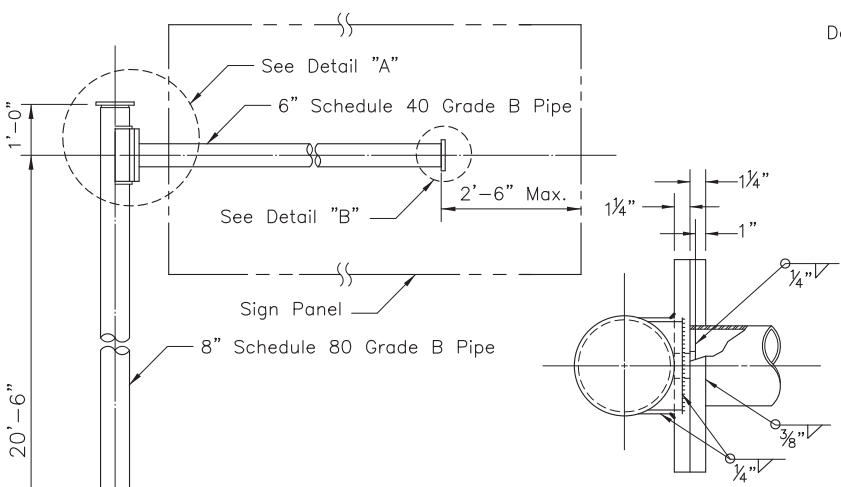

Detail "A"

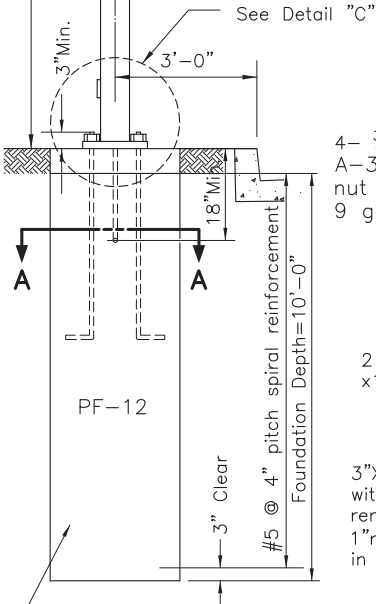
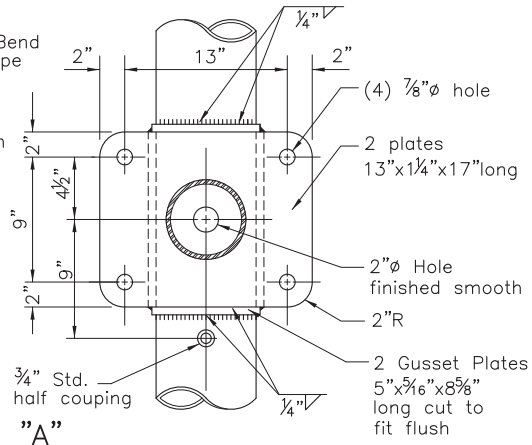

Caisson Concrete shall be 560-C-3250

Four anchor bolts $1\frac{1}{2}$ " ϕ x 54" includes a 6" right angle bend, thrd. 8", galv. tap. 12", 2 hex. nuts & 2 std. washers each.

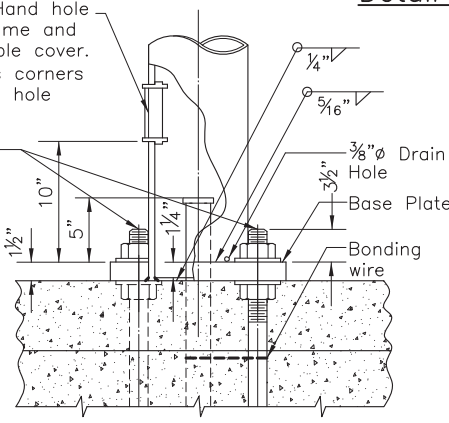

Detail "C"

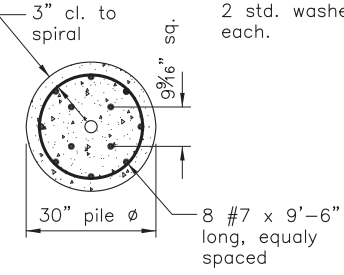

Section A-A

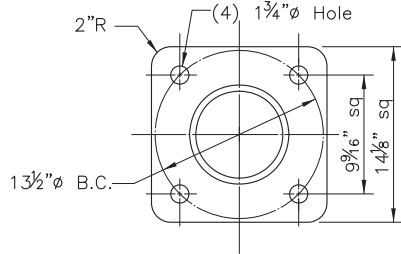

Base Plate

General Notes:

1. All metal parts shall be galvanized after fabrication.
2. All pipes shall conform to ASTM A53 Grade 8.
3. Welding shall be in conformance with AWS specifications "Welded Highway & Railway Bridges", dated 1966, revised 1967.
4. Tapered tube of equivalent size & capacity may be substituted for pipe post subject to the approval of the Engineer.
5. Sign arms shall be made level by raking the standard with the leveling nuts or other method approved by the Engineer to compensate for dead load deflection.
6. All structural steel shall conform to ASTM designation A7 or A36.
7. See S-45.0 for sign dimensions, positioning and mounting.

Original Approved 1-24-1978
by Philp H. Skarin

Revisions		Title
Date	Init.	
		Sign, Cantilever, 12' Arm Special (Arm Mounting Height 20'-6") CITY OF LOS ANGELES DEPARTMENT OF TRANSPORTATION Frances T. Banerjee, General Manager
		Approved 11-15-99 Drawing No.
		 S-98.0

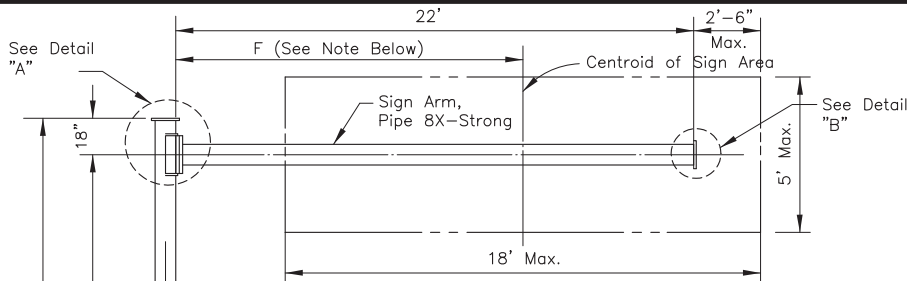

Notes:
 1. Total sign area shall not exceed 90 sq. ft.
 2. Length "F" shall not exceed 15.5 feet with maximum sign area.

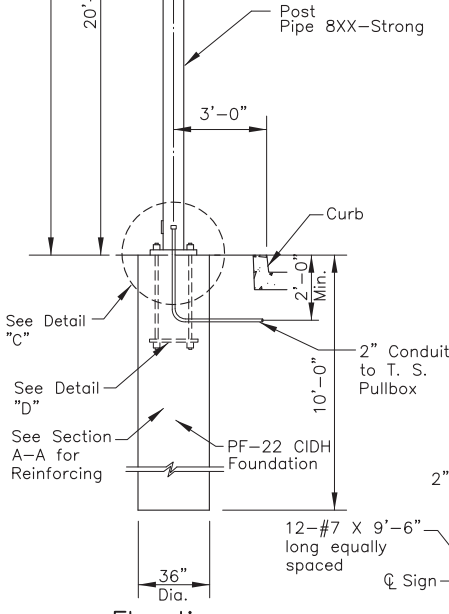

Elevation
Not to Scale

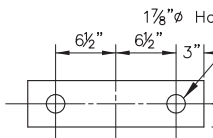

Detail "D"
Not to Scale

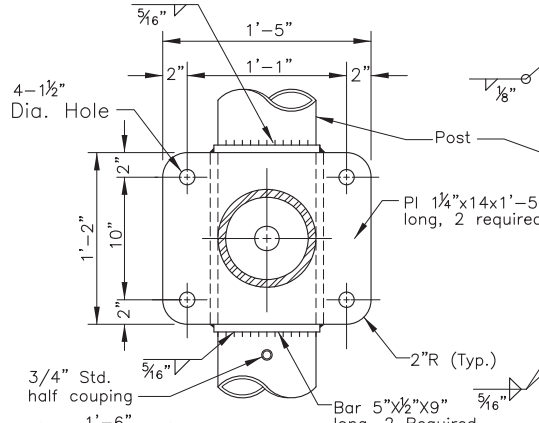

Section A-A
Not to Scale

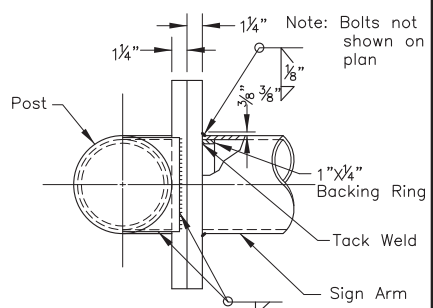

Detail "A"
Not to Scale

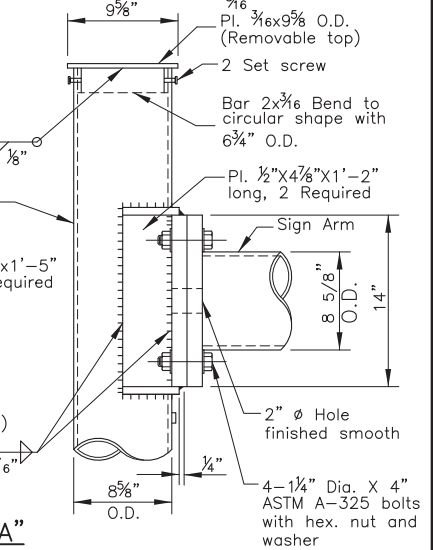

Specification

Design:
 A.A.S.H.O. Specifications for the Design and Construction of Structural Supports for Highway Signs, dated 1968.

Loading: Wind, Normal to sign face: 23.3 psi.
 Transverse to force; 0.2 of normal force

Unit Stresses:
 Structural steel fb = 23,000 psi
 Reinforcing Steel fs = 24,000 psi
 Concrete: n=10 fc = 3000 psi
 fc = 1200 psi
 Soil Bearing Pressure c = 3,000 psi

General Notes:

- All metal parts shall be galvanized after fabrication.
- All pipes shall conform to ASTM A53 Grade 8 specification.
- Welding shall be in conformance with AWS-D2.0 specifications "Welded Highway & Railway Bridges", dated 1969.
- Tapered tube of equivalent size & capacity may be substituted for pipe post subject to the approval of the Engineer.
- Sign arms shall be made level by raking the standard with the leveling nuts or other method approved by the Engineer to compensate for dead load deflection.
- All structural steel shall conform to ASTM designation A36, except as shown on plan.
- See S-45.0 for sign dimensions, positioning and mounting.

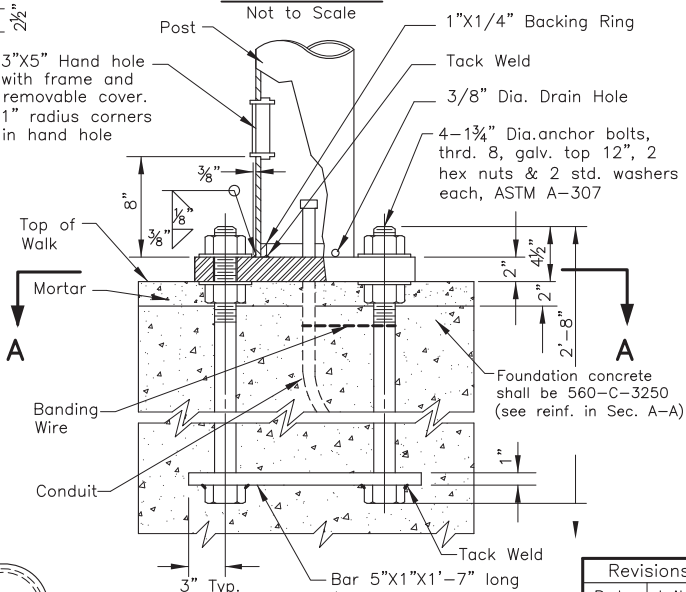

Detail "C" PF-22
Not to Scale

Note: Sign mounting assembly not shown on detail.

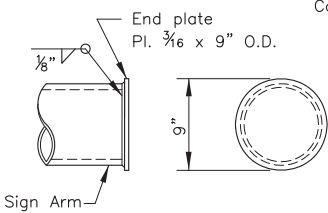

Detail "B"
Not to Scale

Original Approved 12-29-70
 by Philp H. Skarin

Revisions		Title
Date	Init.	
		22' Cantilever Sign Standard Detail CITY OF LOS ANGELES DEPARTMENT OF TRANSPORTATION Frances T. Banerjee, General Manager
		Approved 11-15-99
		Drawing No. S-92.3

Specification

Design:
A.A.S.H.O. Specifications for the Design and Construction of Supports for Highway Signs, dated 1968.

Loading: Wind, Normal to sign face: 23.3 psf
Transverse to face; 0.2 of normal force

Unit Stresses:
Concrete: $n=10$ $f_c = 3000$ psi
 $f_c = 1200$ psi
Reinforcing Steel $f_s = 24,000$ psi
Structural steel $f_b = 23,000$ psi
Soil Bearing Pressure = 23,000 psf

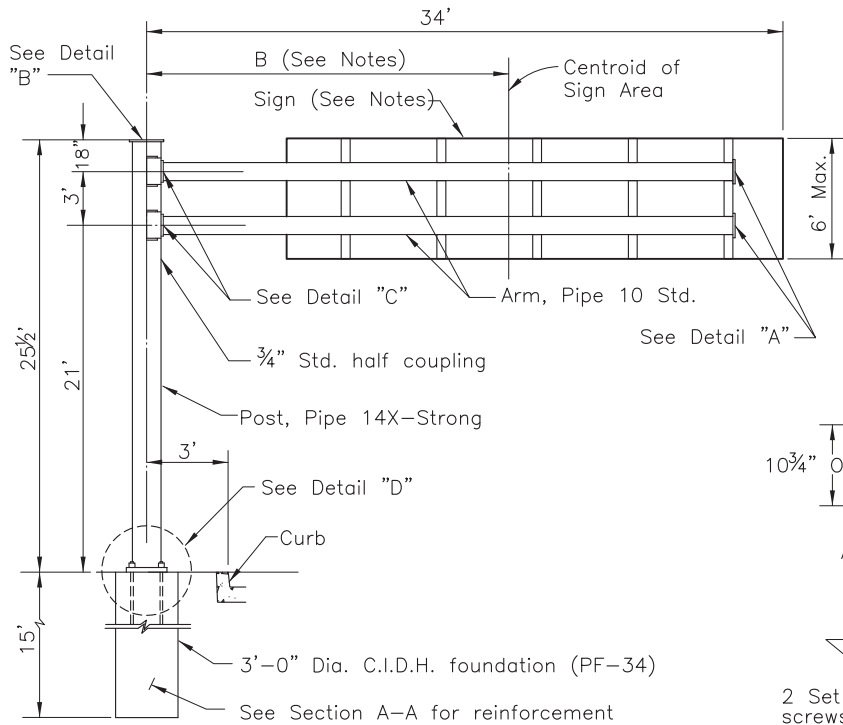

Monotube Overhead Sign Supports

Not to Scale

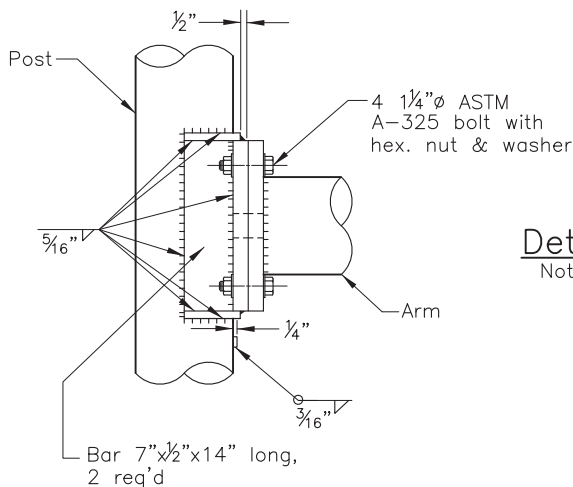
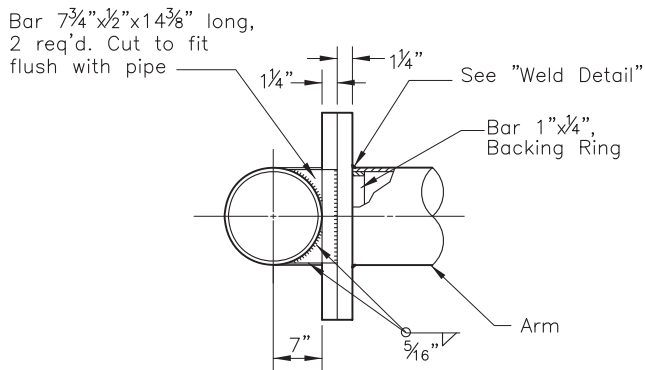
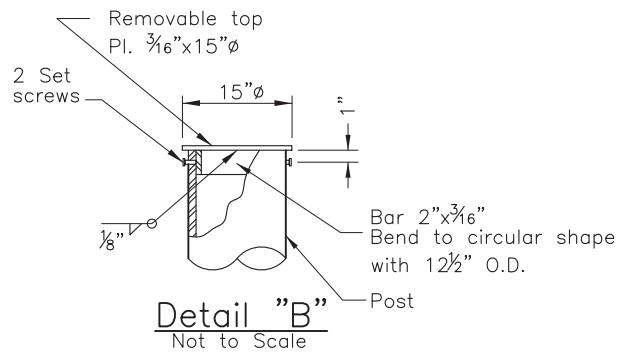
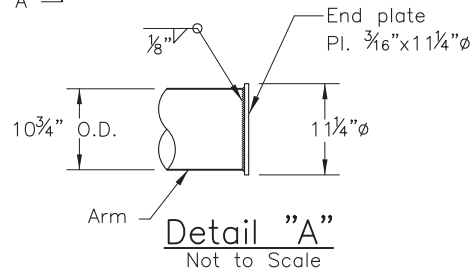

Detail "C"
Not to Scale

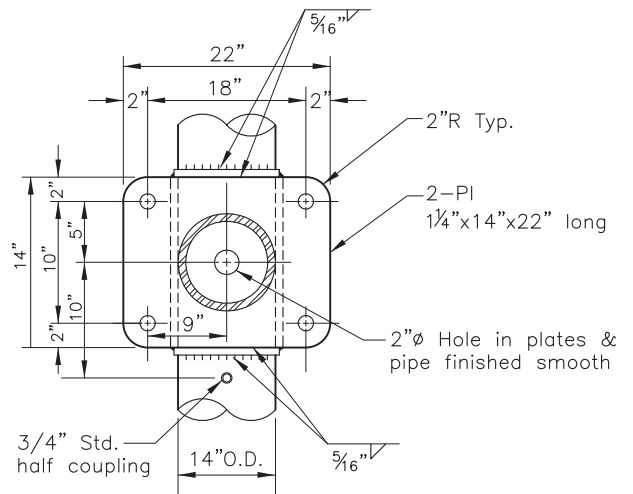

APPROVED

Robert R. Yates 5-26-96

General Manager

**34' CANTILEVER SIGN
STANDARD AND FOUNDATION
DETAILS**

1
2

CITY OF LOS ANGELES
DEPARTMENT OF TRANSPORTATION
Robert R. Yates, General Manager

KCD.	SR. T.E. TJ	PR. T.E. JEF
DWN. EC	T.E. KF	S-92.2

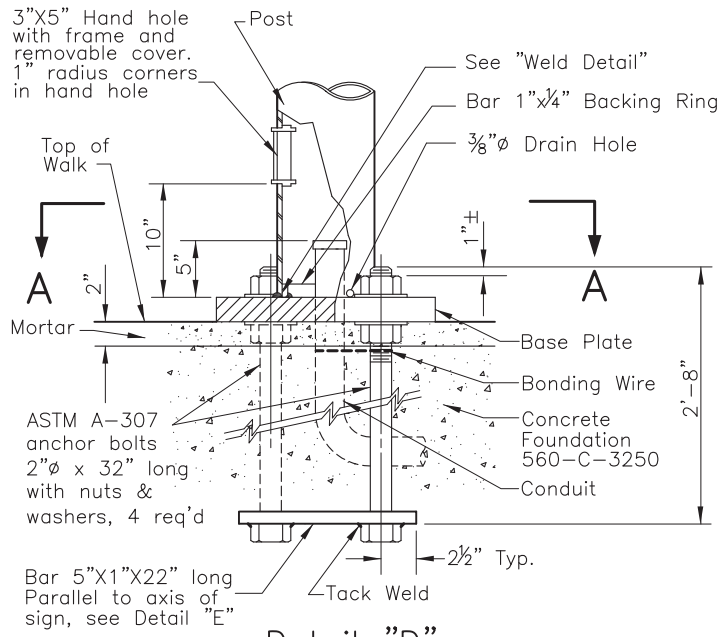

Detail "D"
Not to Scale

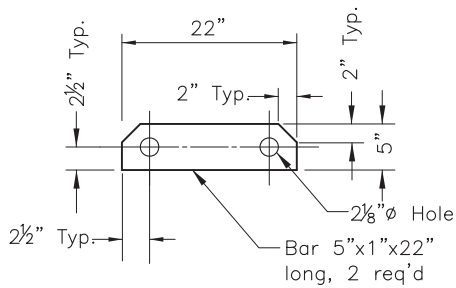

Detail "E"
Not to Scale

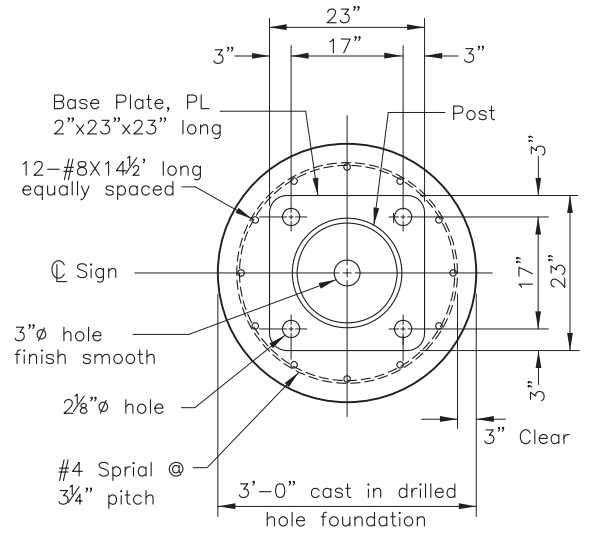

Section A-A
Not to Scale

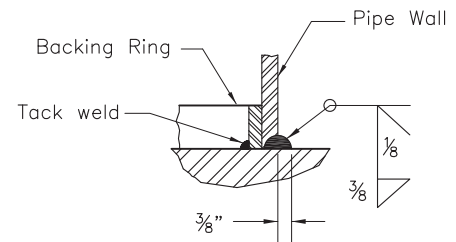

Weld Detail
Not to Scale

General Notes:

1. Total sign area shall not exceed 180 sq. ft.
2. Length "B" shall not exceed 22' with maximum sign area.
3. See plan for positioning of panel.
4. All metal parts shall be galvanized after fabrication.
5. All pipes shall conform to ASTM A53 Grade B specification.
6. Welding shall be in conformance with AWS D2.0 specifications "Welded Highway & Railway Bridges", dated 1969.
7. Tapered tube of equivalent size & capacity may be substituted for pipe post subject to the approval of the Engineer.
8. Sign arms shall be made level by raking the standard with the leveling nuts or other method approved by the Engineer to compensate for dead load deflection.
9. All structural steel shall conform to ASTM designation A36, except where otherwise shown.

APPROVED			
Robert R. Yates			5-26-96
General Manager			
34' CANTILEVER SIGN STANDARD AND FOUNDATION DETAILS			2 2
CITY OF LOS ANGELES DEPARTMENT OF TRANSPORTATION Robert R. Yates, General Manager			
DWN.	LCJ	T.E.	K.F. PR. T.E. JEF
CKD.		SR. T.E.	T.J. S-92.2

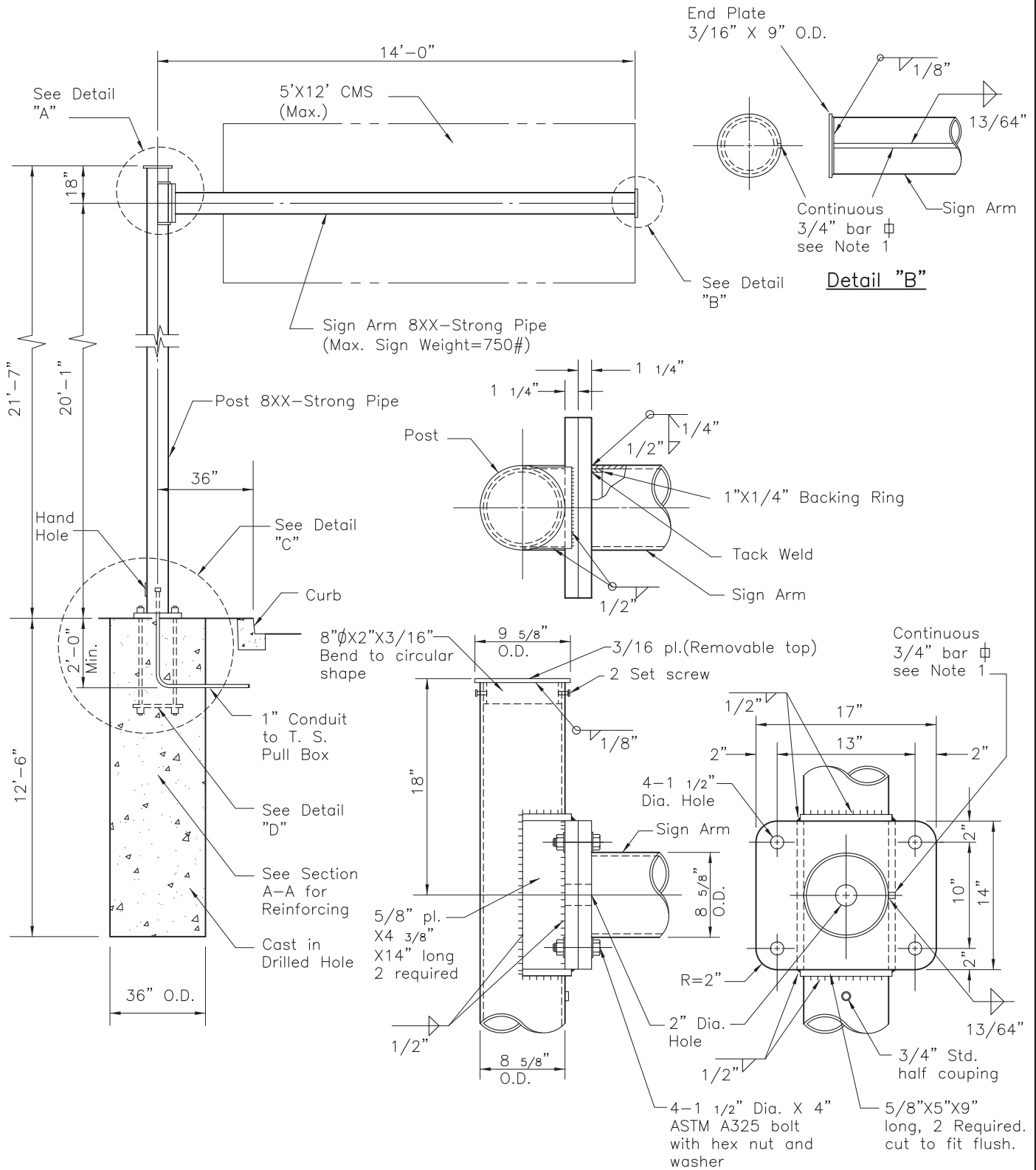

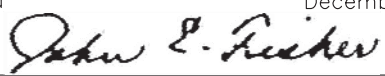
DWN	MT	11-03-05	Title 14' Cantilever Changeable Message Sign 1/2
CKD			
T. E.			CITY OF LOS ANGELES DEPARTMENT OF TRANSPORTATION
Sr. T. E.	SS	12-9-05	
Pr. T. E.			
Approved			December 9, 2005
 for Frances T. Banerjee, Interim General Manager			Drawing No. S-92.4

Approved on 11-21-05
Structural Engineering Division, BOE
by Peter Chiu

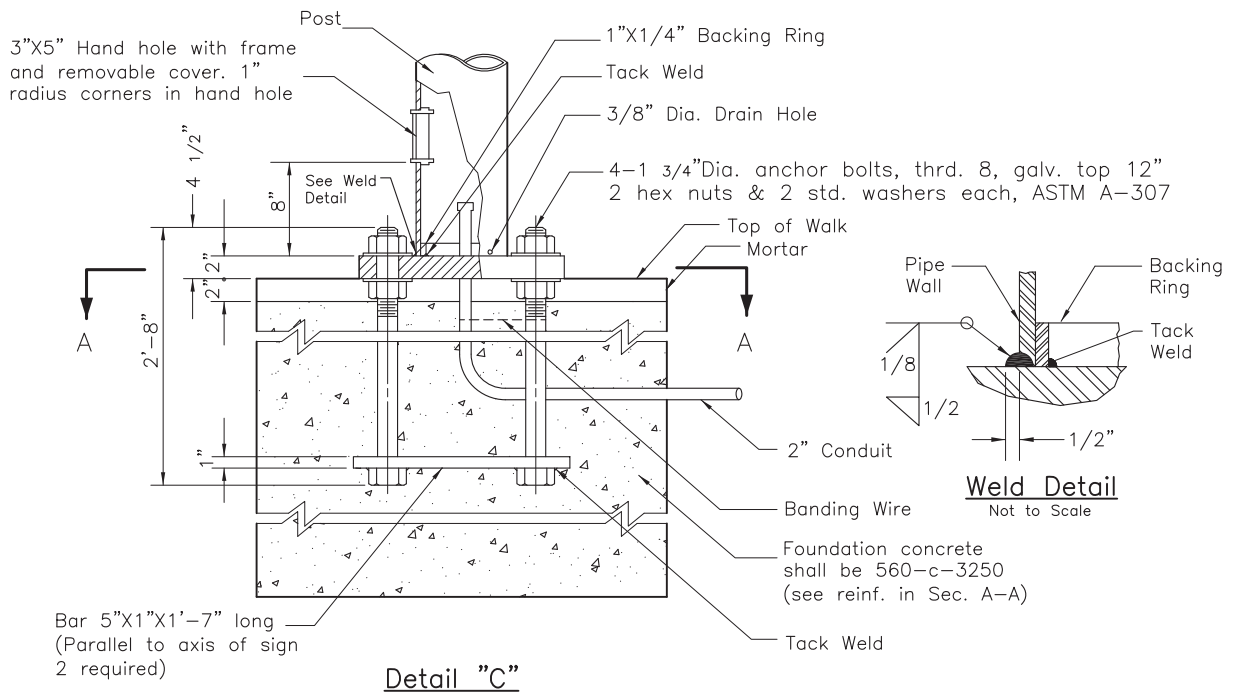
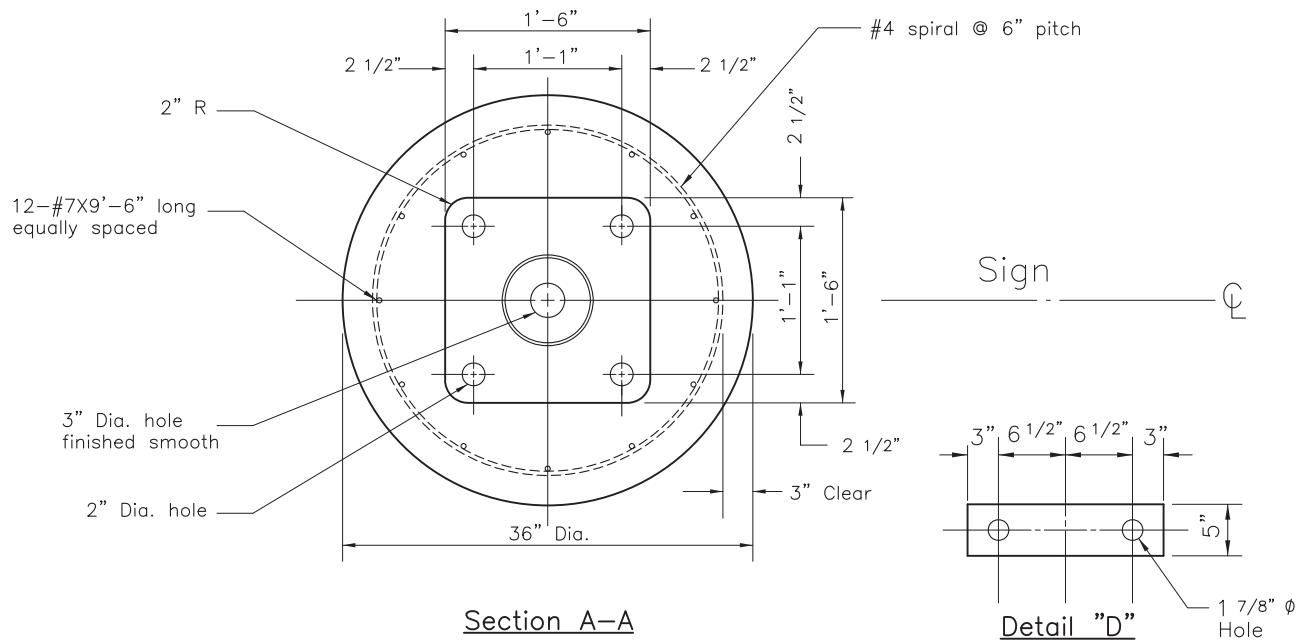

Specifications

Design:
2001 AASHTO Standard Specifications for structural supports for Highway Signs, Luminaires, and Traffic Signals.

Wind Velocity:
85 MPH

General Notes

1. All pipes shall conform to ASTM A53 Grade B Specifications.
2. Bar reinforcements shall conform to ASTM A615, Grade 60.
3. All structural steel shall conform to ASTM designation A36, except as shown on the plan.
4. Welding design and fabrication shall be in accordance with the latest edition of the AWS Structural Welding Code D1.1-Steel.
5. All metal parts shall be galvanized after fabrication.
6. Sign Arm shall be made level by raking the standard with the leveling nuts or other method approved by the Engineer to compensate for dead load deflection.
7. Mounting Brackets shall be per Caltrans Standard Drawing No. S40R.

CITY OF LOS ANGELES
DEPARTMENT OF TRANSPORTATION

Title **14' Cantilever Changeable Message Sign**



Drawing No.
S-92.4

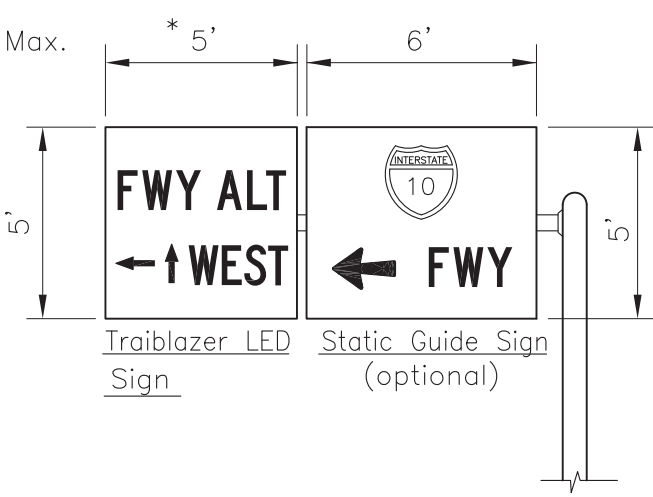
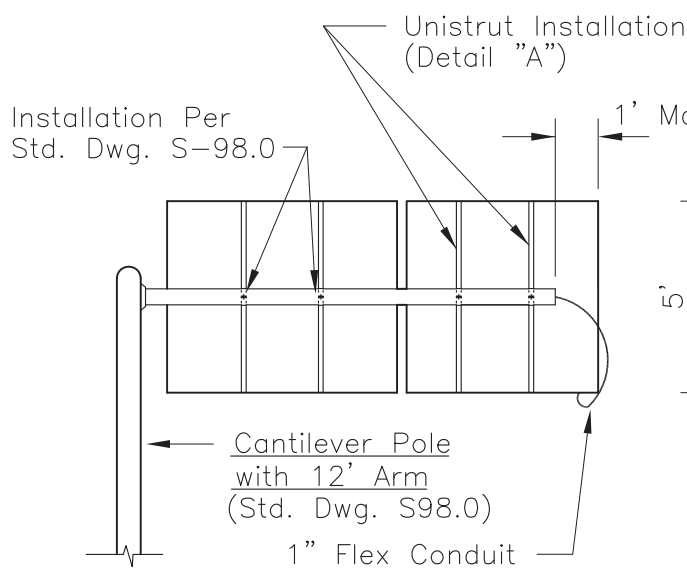
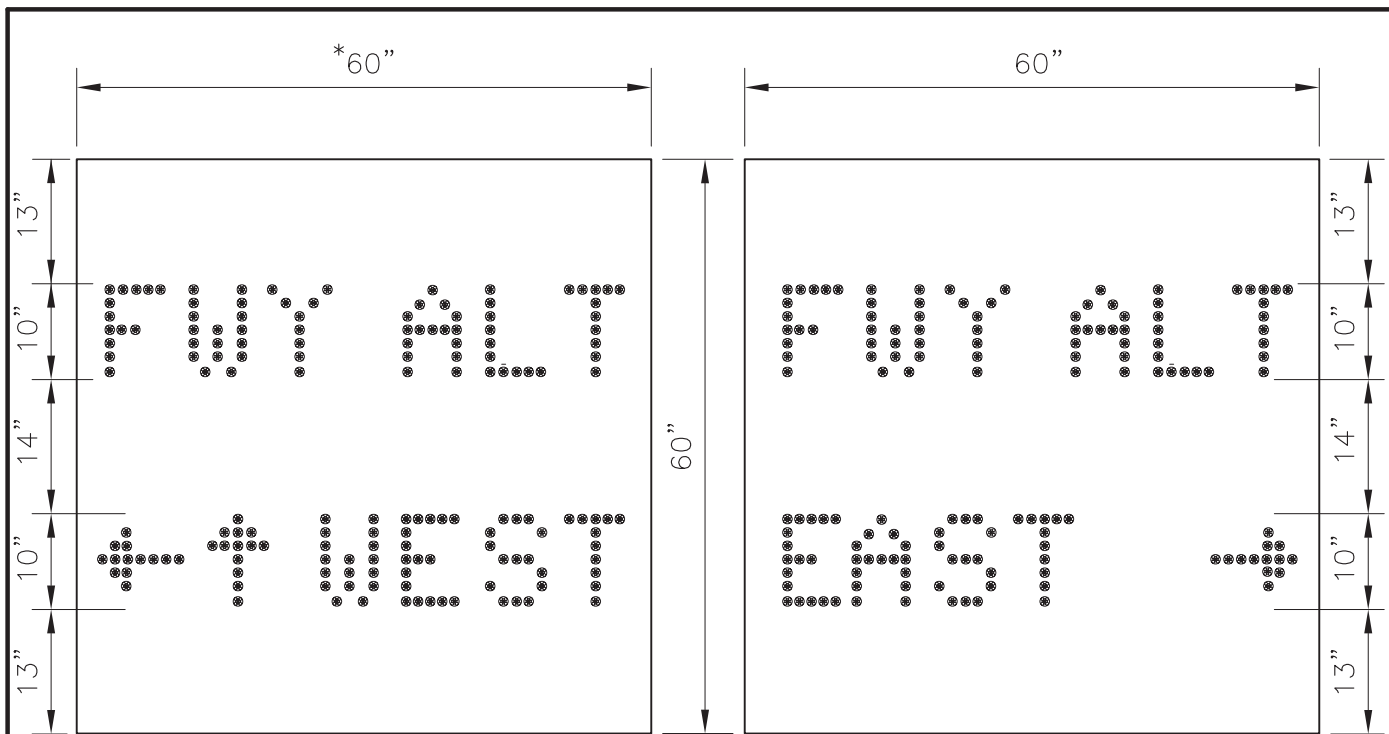

REAR VIEW
(Not To Scale)

FRONT VIEW
(Not To Scale)

* WIDTH CAN BE INCREASED BY 12 INCHES TO ACCOMMODATE "NORTH" OR "SOUTH" LEGEND.

			Title		TRAILBLAZER SIGN		1/2
			CITY OF LOS ANGELES DEPARTMENT OF TRANSPORTATION ROBERT R. YATES, General Manager				
Drawn By	AH/HM	6-20-96	Approved Robert R. Yates General Manager	8-19-96 Date	DRAWING NO. S-58.16		
Checked By	ID	6-20-96					
Supervised By	VJ	6-20-96					
Reviewed By	JEF	8-15-96					

Aluminum Channel & Closure Strip
 Weight: 0.66lbs/ft (0.98kg/m)
 Thickness: 0.105" (2.6mm)

Slotted
 Hex Head
 Machine
 Screw &
 Square
 Nut

Pipe Clamps
 O.D. 6 5/8"
 Thickness: 11Ga
 Design Load 100 lbs

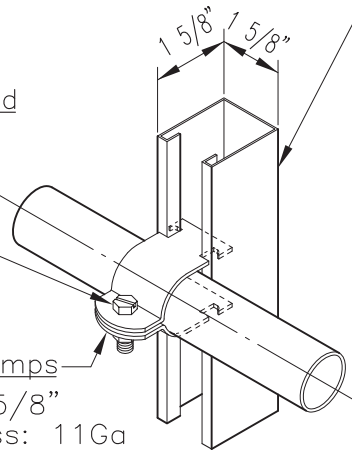

DETAIL "A"
 (Not To Scale)

1. Trailblazer signs to be used in conjunction with static freeway overhead guide signs.
2. Use one or two arrows on the trailblazer sign as appropriate.
3. Sign shall utilize Light Emitting Diodes (LED) for message illumination. The individual LED's shall equal or exceed in quality as those manufactured by Hewlett-Packard, high power ALInGAP amber type, catalog #HLMA-DL00.
4. Sign text shall be 10" U.C. with 1" spacing between each letter and a minimum of one letter width spacing between words.
5. The overall sign size shall be 60" in height x 60" in width and 8" in depth.
6. The weight of the sign (enclosure + all components) shall not exceed 115 lbs.
7. The sign shall be constructed so that the front face panel shall be contained within an extruded 0.90 aluminum frame having full welded seams and powder coat painted with high gloss black finish meeting the color standards of Fed. Spec. 595b, 17038.
8. The transparent Lexan front face panel shall be hinged at the top allowing front access to the interior of the sign. Support shall be provided to hold the Lexan panel open during maintenance.
9. A honeycomb formed black anodized screen shall be provided between the LED's lamp clusters and the front face panel to enhance resistance to "sun phantom" effect.
10. The sign shall use a closed cell neoprene gasket making the sign watertight.
11. Sign enclosure hardware materials shall be stainless steel AISI303, for corrosion resistance.
12. An opening shall be made on the bottom side of the sign so that all conductors, enclosed in flexible conduit, may exit from the sign into the cantilever arm.
13. The sign shall be vented in the bottom portion on the opposite end from the conductor opening.
14. The LED elements shall be comprised of individual removable modules. Each LED modules shall be composed of 1" pixels (clusters) having 8 each LED's per pixel. One module shall be used for each letter of the message.
15. Each pixel shall be removable or replaceable on the module without the use of any tools other than a screwdriver.
16. The sign shall be equipped with a photoelectric cell mounted on the enclosure to measure ambient light intensity and automatically compensate for ambient light conditions.
17. The LED sign shall be mountable using unistrut mounting system.
18. Sign shall be equipped with a terminal block to provide separate power inputs to each of the text and arrow modules. The sign shall be powered with 120V AC.
19. A full set of proposed sign specifications and drawings shall be supplied to the City prior to manufacturing.

Title	TRAILBLAZER SIGN		
CITY OF LOS ANGELES DEPARTMENT OF TRANSPORTATION ROBERT R. YATES, General Manager			
Drawn By	AH/HM	6-20-96	Approved Robert R. Yates 8-19-96 General Manager Date
Checked By	ID	6-20-96	
Supervised By	VJ	6-20-96	
Reviewed By			
			DRAWING NO. S-58.16

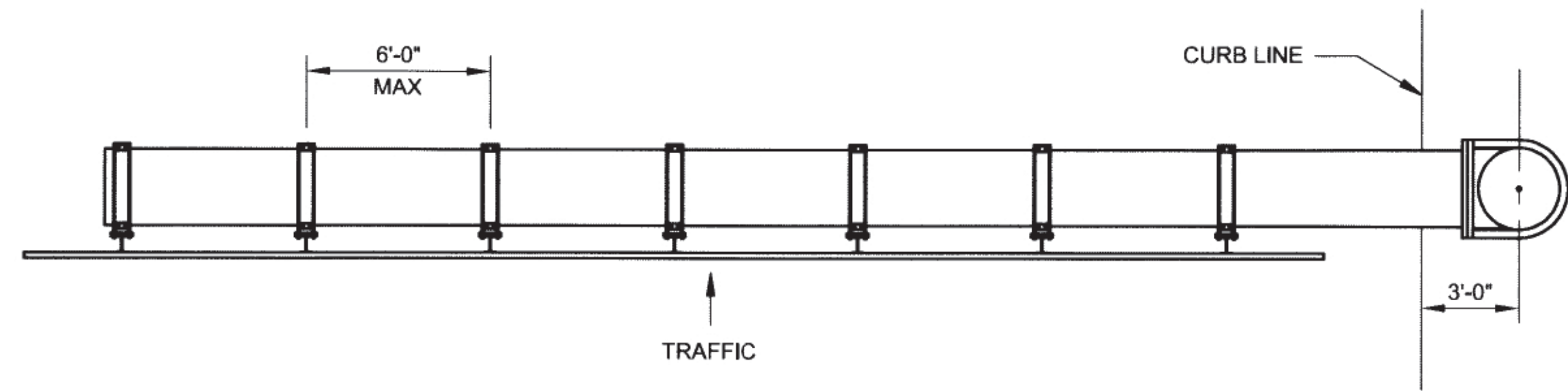

INDEX TO SHEETS				
SHEET NO.	DWG. NO.	TITLE	DATE	BY
1	S-1	MONOTUBE CANTILEVER SIGN		
2	S-2	TUBULAR STRUCTURAL FRAME DETAILS - 1		
3	S-3	TUBULAR STRUCTURAL FRAME DETAILS - 2		
4	S-4	TUBULAR BASE PLATE AND ANCHORAGE DETAILS		
5	S-5	ROUND PEDESTAL PILE FOUNDATION		

GENERAL NOTES:
DESIGN:
 SIGN SUPPORT STRUCTURES DESIGNED IN ACCORDANCE WITH AASHTO STANDARD SPECIFICATIONS FOR STRUCTURAL SUPPORT FOR HIGHWAY SIGNS LUMINAIRES AND TRAFFIC SIGNALS: 5TH EDITION.

SIGN WEIGHT USED FOR SIGN SUPPORT STRUCTURE DESIGN IS 3 PSF.

BASIC WIND SPEED (3 SECOND GUST) USED FOR SIGN SUPPORT STRUCTURES DESIGN IS 100 MPH, $G = 1.14$, $I = 1.0$ (50 YEAR RECURRENCE INTERVAL).

FATIGUE IMPORTANCE FACTOR, $I_f = 1.0$, USED FOR FATIGUE DESIGN OF SIGN SUPPORT STRUCTURES CONSIDERING GALLOPING, NATURAL WIND GUST AND TRUCK-INDUCED GUST.

PIPE MEMBERS SHALL CONFORM TO ASTM A53 GR. B.

HSS TUBE MEMBERS SHALL CONFORM TO ASTM A500 GR. B.

ALL OTHER STRUCTURAL STEEL SHALL CONFORM TO ASTM A36, OR A992, UNLESS NOTED OTHERWISE.

WELDING SHALL BE IN CONFORMANCE WITH THE LATEST EDITION OF AWS - D1.1 STRUCTURAL WELDING CODE.

NOTCH TOUGHNESS OF ALL STRUCTURAL STEEL MEMBERS AND PLATES GREATER THAN $\frac{3}{8}$ " THICK SHALL CONFORM TO ZONE 2 REQUIREMENTS OF AASHTO M270/M270 SUPPLEMENTARY REQUIREMENT S5 (ASTM A709/A709M, SUPPLEMENTARY REQUIREMENT S83).

HIGH STRENGTH BOLTS SHALL CONFORM TO ASTM A325, TYPE 1.

NUTS FOR HIGH STRENGTH BOLTS SHALL BE HEAVY HEX AND CONFORM TO ASTM A563 GRADE DH, WITH SUPPLEMENTARY REQUIREMENTS "S1" AND "S2".

HARDENED STEEL WASHERS SHALL CONFORM TO ASTM F436, TYPE 1. USE WASHERS UNDER TURNING ELEMENT IN TIGHTENING UNLESS OTHERWISE SPECIFIED.

ALL FASTENERS SHALL BE HOT-DIP GALVANIZED.

ALL STRUCTURAL STEEL SHALL BE HOT-DIP GALVANIZED AFTER FABRICATION, UNLESS NOTED OTHERWISE.

THE SILICON CONTENT OF THE BASE METAL SHALL BE IN THE RANGES OF 0.0% TO 0.04% OR 0.15% TO 0.25% FOR ALL HOT-DIP GALVANIZED STEEL, UNLESS NOTED OTHERWISE.

ALL H.S. BOLTS SHALL BE CONSIDERED SLIP CRITICAL UNLESS NOTED OTHERWISE. DESIGN SLIP RESISTANCE FOR BOLTS SHALL CONFORM TO THE BOLT SPECIFICATIONS FOR CLASS C SLIP COEFFICIENT = 0.33.

USE SELF LOCKING NUTS ON NON-HIGH STRENGTH (H.S.) BOLTS, UNLESS OTHERWISE SHOWN OR SPECIFIED.

FOUNDATION DESIGN IS BASED ON BROMS' METHOD ASSUMING A COHESIVE SOIL WITH AN UNDRAINED SHEAR STRENGTH OF 1.50 KSF WITH A FACTOR OF SAFETY OF 3.0.

PILE LENGTHS SHALL BE INCREASED BY AN AMOUNT EQUAL TO THE THICKNESS OF ANY EXISTING FILL SOILS ENCOUNTERED AT THE SIGN LOCATION DURING CONSTRUCTION.

BUREAU OF ENGINEERING'S GEOTECHNICAL ENGINEERING GROUP (213-847-0538) SHALL BE CONTACTED FOR RECOMMENDATIONS IF WEAK SOILS AND/OR GROUNDWATER IS ENCOUNTERED DURING CONSTRUCTION OF THE CIDH PILES.

ALL CONCRETE SHALL BE CLASS 3600.

ALL REINFORCING STEEL SHALL CONFORM TO ASTM A706 OR A615 GR. 60.

ANCHOR RODS SHALL CONFORM TO ASTM F1554, GR. 55, WITH SUPPLEMENTARY REQUIREMENT "S4" (AASHTO M314). TOP ENDS OF ANCHOR RODS SHALL BE GROUND FLAT AT 90° TO ROD AXIS. FINAL SURFACE ROUGHNESS SHALL NOT EXCEED 125 MICRO-INCH.

ANCHOR ROD WASHERS SHALL CONFORM TO ASTM F436.

ANCHOR ROD NUTS SHALL CONFORM TO ASTM A563 GRADE DH WITH SUPPLEMENTARY REQUIREMENTS "S1" AND "S2".

ANCHOR RODS SHALL BE HOT-DIP GALVANIZED FULL LENGTH.

I1 CANTILEVER SIGN SUPPORT PLAN
 SCALE : 1/4" = 1'-0" S-1

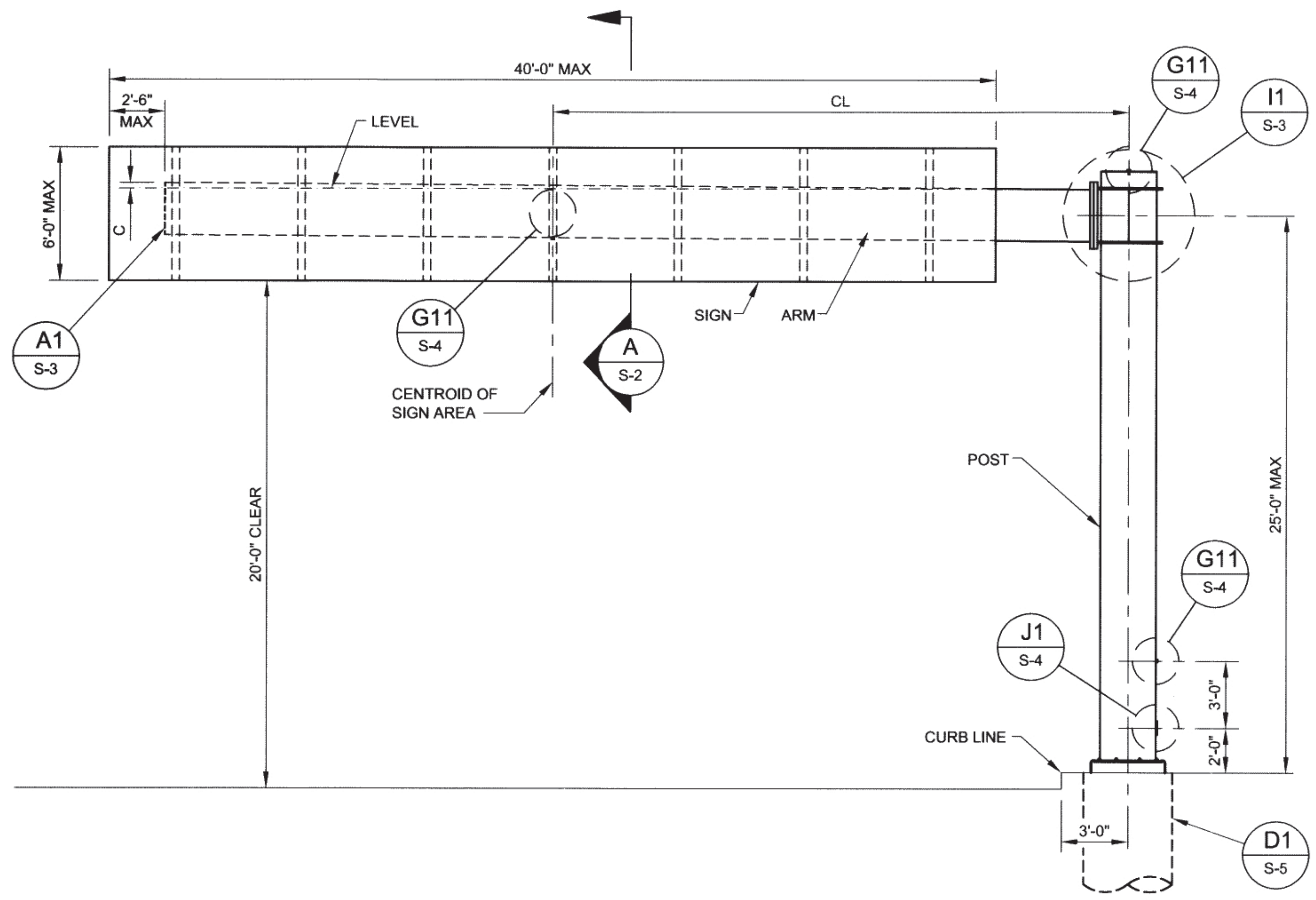

C1 CANTILEVER SIGN SUPPORT ELEVATION
 SCALE : 1/4" = 1'-0" S-1

STRUCTURE NO.	SIGN LENGTH	MAX CL	MAX SIGN AREA	Dp	tp	Wa	ta	Ra	C
1	10'-20'	16'-0"	120 FT ²	1'-6"	$\frac{3}{8}$ "	1'-4"	$\frac{1}{2}$ "	2 $\frac{1}{2}$ "	3"
2	20'-30'	21'-0"	180 FT ²	2'-0"	$\frac{3}{8}$ "	1'-10"	$\frac{1}{2}$ "	2 $\frac{1}{2}$ "	4 $\frac{1}{4}$ "
3	30'-40'	26'-0"	240 FT ²	2'-6"	$\frac{5}{8}$ "	2'-4"	$\frac{1}{2}$ "	2 $\frac{1}{2}$ "	5"

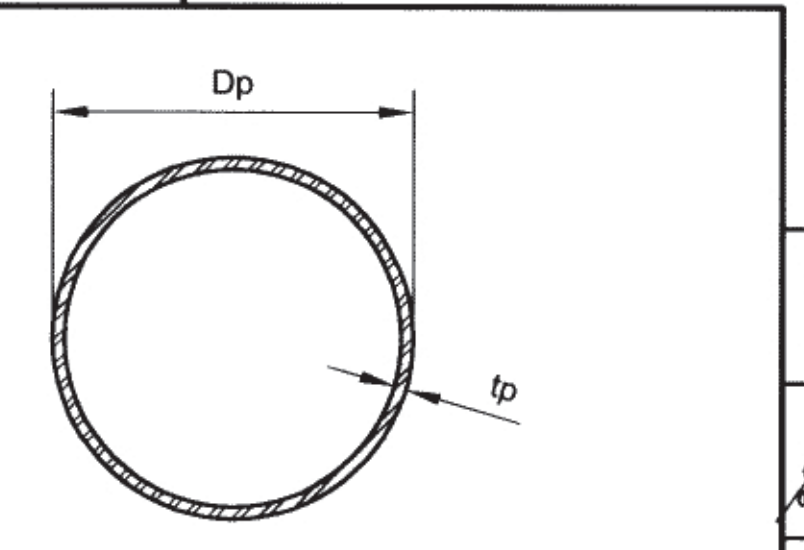
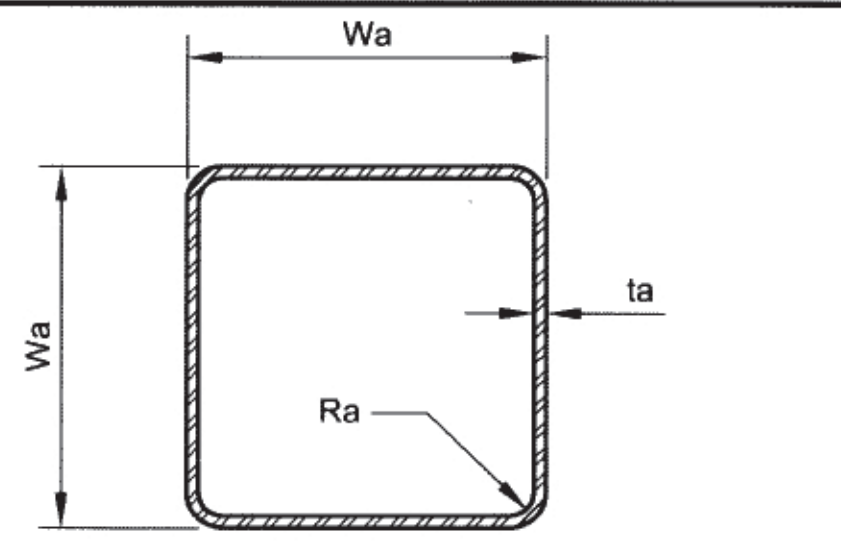

A1 TUBE SELECTION TABLE
 SCALE : NTS S-1

A8 TYP ARM SECTION
 SCALE : 3/4" = 1'-0" S-1

A12 TYP POST SECTION
 SCALE : 3/4" = 1'-0" S-1

REVIEWED: <i>July 7, 2011</i> Srinivasan Transportation Engineer	SUBMITTED: _____ Senior Transportation Engineer	ACCEPTED: <i>July 15, 2011</i> <i>Dean Sichen</i> Principal Transportation Engineer
AS BUILT Date of Installation: _____ LADOT Inspector: _____ Condition As Of: _____ LADOT Engineer: _____ District: _____ Thomas Guide: PGE GR References: TitleBlock.dwg		
CITY OF LOS ANGELES DEPARTMENT OF TRANSPORTATION AMIR H. SEDADI, Interim General Manager TITLE OVERHEAD SIGN STRUCTURE STANDARD DRAWINGS MONOTUBE CANTILEVER SIGN		
File Name: S-99.0	Intersection No. _____	Project No. 50346

(LADOT Revised 6/04)
 (Drafting Std. 11/04)

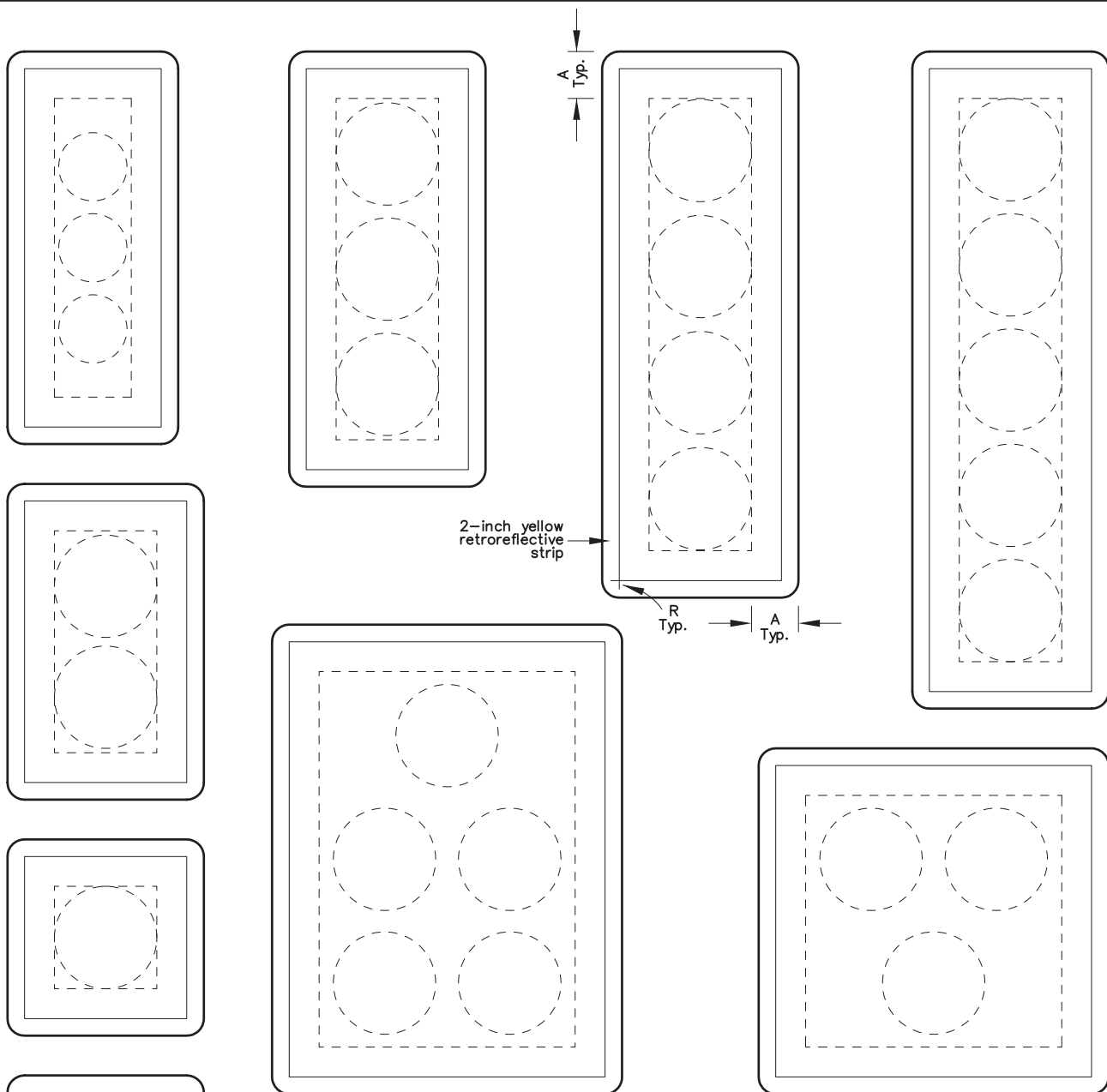

NOTES:

1. THE WIDTH DIMENSION, "A" SHOULD BE 5" TYP. AND THE CORNER RADIUS DIMENSION, "R", SHOULD BE 2" TYP. THE BACKPLATE SHALL HAVE A NOMINAL THICKNESS OF 1/8". ALL OUTSIDE AND INSIDE EDGES SHALL BE FORMED WITH A 1/2" TO 5/8" FLANGE (INSIDE DIMENSION), TURNED AWAY FROM THE FRONT SURFACE.
2. FOR ALL MANUFACTURED SIGNAL HEADS, BACKPLATES SHALL BE DESIGNED SO AS TO SHOW NO BACKGROUND LIGHT BETWEEN THE BACKPLATE AND THE HEAD. THE FABRICATION SHALL BE VACUUM FORMED AS ONE PIECE WITH A BLACK LUSTERLESS, HAIRCELL FINISH ON THE FRONT SIDE. ALL SURFACES SHALL BE FLAT AND STRAIGHT WITHOUT BLISTERS, BUCKLING OR WARPING. FLANGES SHALL BE STRAIGHT, UNIFORM AND HAVE A CONSISTENT FLANGE DIMENSION THROUGHOUT.
3. THE BACKPLATE MATERIAL SHALL BE COMPOUNDED FROM VIRGIN ABS CONTAINING 60% STYRENE, 20% RUBBER AND 20% ACRYLIC. IT SHALL CONTAIN ULTRA VIOLET INHIBITORS AND STABILIZERS FOR PROTECTION AGAINST ULTRA VIOLET DEGRADATION. THE BACKPLATE MUST MEET A FALLING DART IMPACT TEST OF 16 FT/LB.
4. THE INTERNAL SHAPES AND DIMENSIONS SHALL MATCH VARIOUS MANUFACTURED SIGNAL HEADS.
5. RETROREFLECTIVE SHEETING MUST BE TYPE XI AND COMPLY WITH ASTM D4956. RETROREFLECTIVE SHEETING MUST HAVE CLASS 1, 3, OR 4 ADHESIVE BACKING. THE ADHESIVE BACKING MUST BE PRESSURE SENSITIVE AND FUNGUS RESISTANT. RETROREFLECTIVE SHEETING MUST BE APPLIED AT THE FABRICATION PLANT UNDER THE RETROREFLECTIVE SHEETING MANUFACTURER'S INSTRUCTION WITHOUT APPRECIABLE STRETCHING, TEARING OR OTHER DAMAGE.

DWN	SB	10-20-25	Title	BACKPLATES	
CKD					
T. E.	SB	10-20-25	CITY OF LOS ANGELES DEPARTMENT OF TRANSPORTATION		
Sr. T. E.	JV	10-20-25			
Pr. T. E.	TF				
Approved			October 20, 2025	Drawing No.	
				S-77.8A	
for Laura Rubio-Cornejo, General Manager					

A. STREET NAME SIGNS

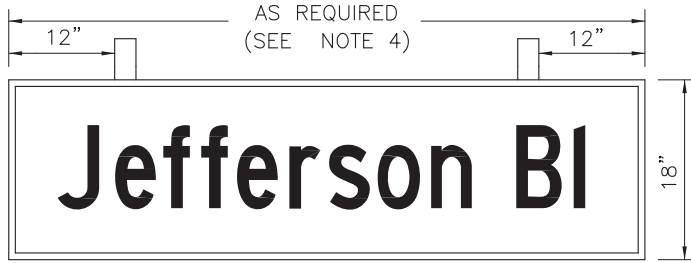

NOTES

1. LEGEND SIZE : 8" UPPER CASE, 6" LOWER CASE, SERIES "E" LETTERS; 11-1/4"x12-3/4" ONE-LINE ARROW
2. COLOR: WHITE LEGEND, BLUE BACKGROUND
3. REFLECTIVITY: HIGH INTENSITY LETTERS ON SUPER ENGINEER GRADE BACKGROUND OR REVERSE SCREENING ON HIGH INTENSITY SHEETING
4. WHERE THE LENGTH OF THE SIGN BLADE WOULD EXCEED 96" (GENERALLY 16 LETTERS AND SPACES) THE STREET NAME TITLES, "ST","AVE","BL","PL","DR","RD", ETC. MAY BE DELETED

B. FREEWAY RAMP SIGNS

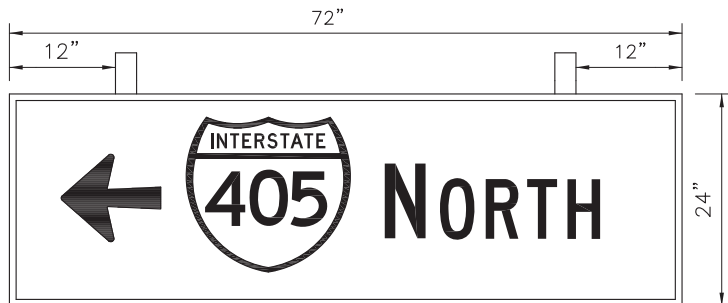

NOTES

1. LEGEND SIZE: 8" AND 6" SERIES D CAPITAL LETTERS; 11-1/4" X 12-3/4" ONE-LINE ARROW; 18" HIGH US, CALIFORNIA OR INTERSTATE SHIELD, AS APPROPRIATE WITH PROPORTIONAL NUMBERS
2. COLOR: WHITE LEGEND, WARBOYS GREEN (L.A. NO.1) BACKGROUND; BLACK ON WHITE US SHIELD; WHITE ON GREEN CALIFORNIA SHIELD; WHITE ON BLUE AND RED INTERSTATE SHIELD
3. REFLECTIVITY: HIGH INTENSITY LETTERS ON SUPER ENGINEER GRADE OR REVERSE SCREENING ON HIGH INTENSITY SHEETING

APPROVED		March 4, 2005
<i>John E. Fisher</i>		
for Wayne K. Tanda, General Manager		
CITY OF LOS ANGELES DEPARTMENT OF TRANSPORTATION		
MAST ARM MOUNTED STREET NAME SIGNS		1 2
CKD.	SR. T.E.	PR. T.E. TLJ
DWN. MT	T.E.	S-486.0

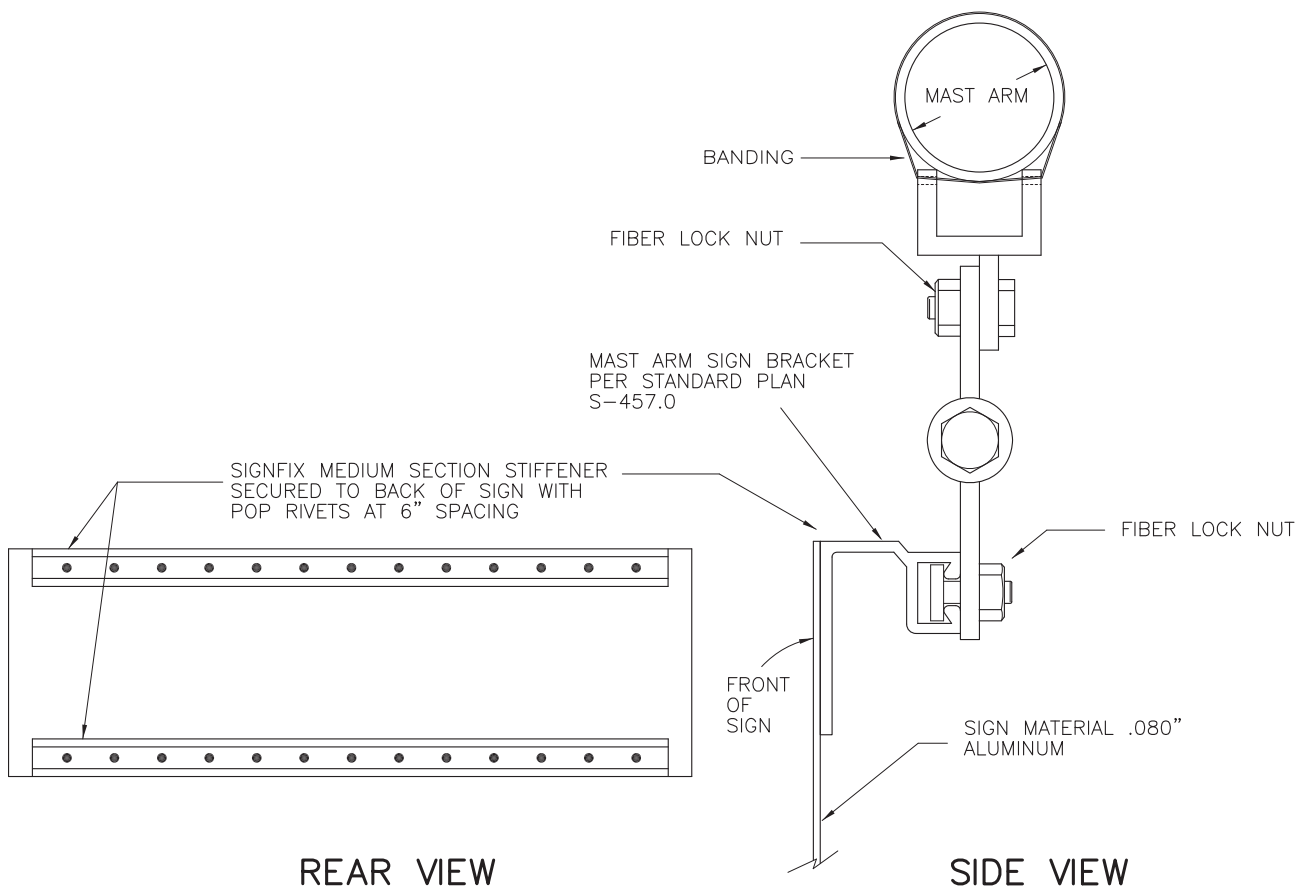
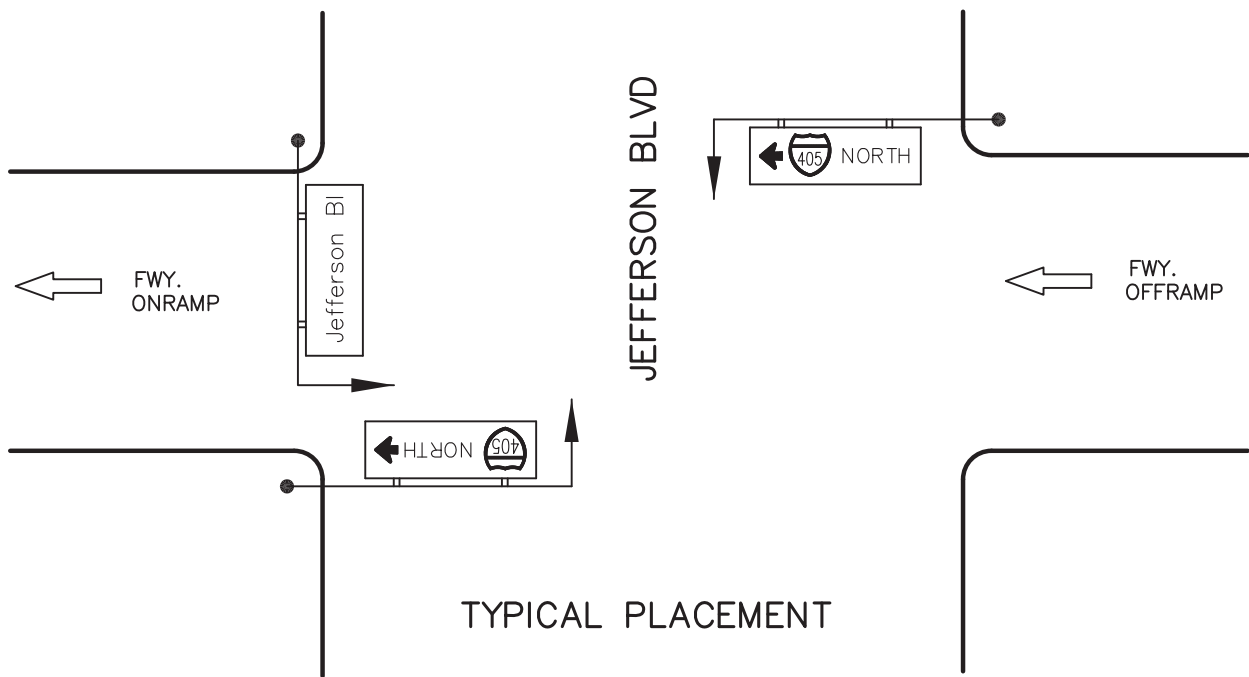

NOTES:

1. FOR INSTALLATION DETAILS SEE STD. PLAN S-457.0
2. FOR SIGNFIX ALUMINUM CHANNEL FRAMING SYSTEM
DETAILS SEE STANDARD PLAN S-476.0

<p>CITY OF LOS ANGELES DEPARTMENT OF TRANSPORTATION</p>	<p>Title MAST ARM MOUNTED STREET NAME SIGNS</p>	<p>Drawing No. S-486.0</p>	<p>2 2</p>
---	--	---------------------------------------	----------------

M10J-OCB250AL

ADJUSTABLE LENGTH SWING SIGN BRACKET

All Aluminum 6061T6 Alloy
and Stainless Steel Components

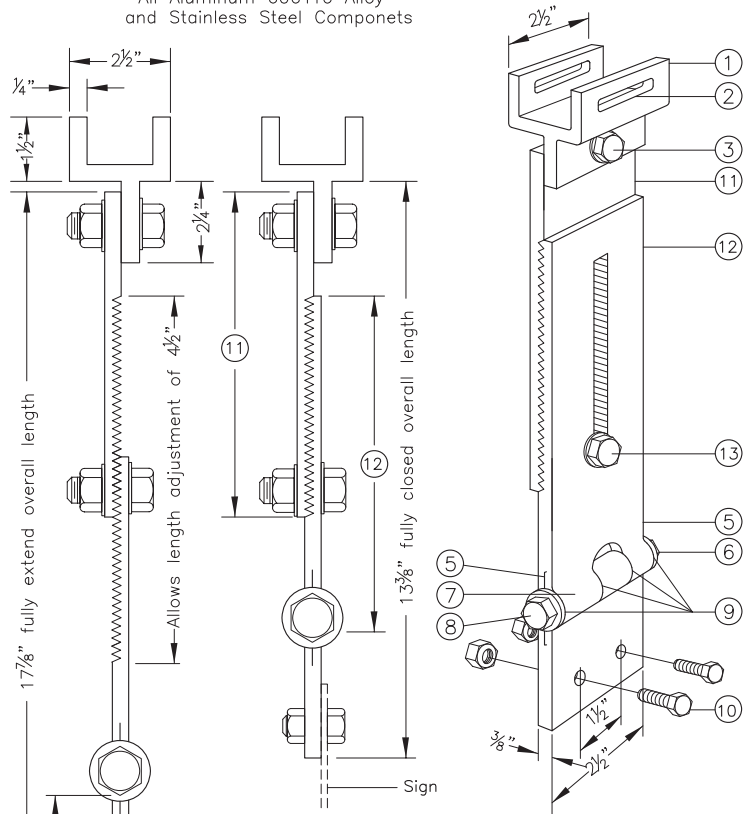

3/8" from bottom of sign mounting hole to bottom of bracket

- ① 7 3/4" Overall length Upper Adjustable Sign Bracket section
- ② 9" overall length Lower Adjustable Sign Bracket section, including Axle Housing (8" overall length to top of Axle Housing)
- ③ 1/2"-13x1 1/2" Stainless Steel Hex Bolt with Stainless Steel Hex Lock Nut and 1/16" Stainless Steel Washers (both sides). Loosen lock nut, adjust bracket teeth to level sign.

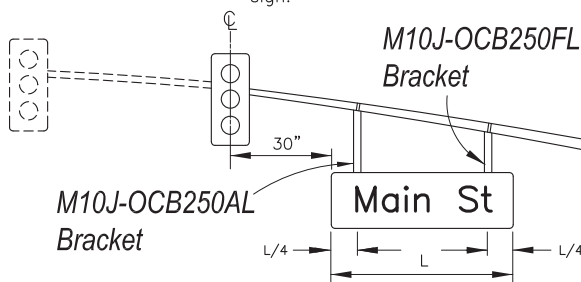

NOTES:

1. Brackets available from:
Hawkins Traffic Safety Supply
1255 Eastshore Highway
Berkeley, CA 94710 (415)525-4040
2. If another sign is installed on the mast arm next to the signal head, the street name sign shall be installed with 12" clearance to the edge of that sign.
3. Sign bracket shall be attached to mast arm with 3/4" wide type 201 stainless steel sign banding secured with a banding buckle. Banding shall be 0.020" thick double banded or 0.030" thick single banded.

M10J-OCB250FL

FIXED LENGTH NON-ADJUSTABLE SWING SIGN BRACKET

All Aluminum 6061T6 Alloy
and Stainless Steel Components

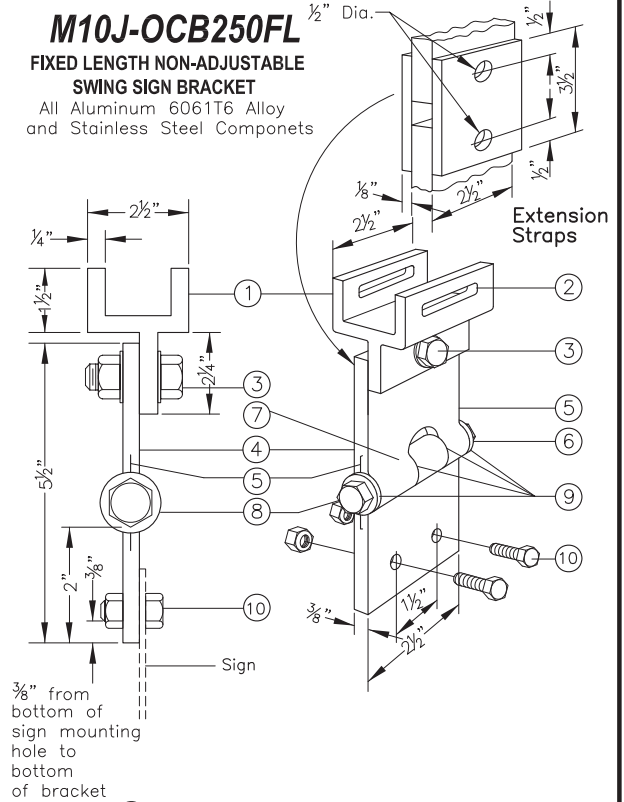

3/8" from bottom of sign mounting hole to bottom of bracket

- ① Pivotal Upper Bracket
- ② 1" x 1/4" Slot for double strapping to electrolier mast arm. Cat. No. M2G-34S(HD) .032" x 1/4" Heavy Duty Stainless Steel Strap with Cat. No. M2G-34B(HD) Buckle recommended
- ③ 1/2"-13x1 1/2" Stainless Steel Hex Head Bolt with Stainless Steel Hex Lock Nut and 1/16" Stainless Steel Washer (both sides). Allows upper bracket to pivot and align with electrolier mast arm. Do not tighten past nut locking feature for pivot action to be operational.
- ④ 5 1/2" Overall length Fixed Length Sign Bracket
- ⑤ Stainless Steel Dampener Spring (Removable)
- ⑥ Stainless Steel Hex Lock Nut with 1/16" Stainless Steel Washer. Do not tighten—it binds hinges
- ⑦ 1" O.D. Axle Housing
- ⑧ 1/2"-13x4" Stainless Steel Hex Head Bolt with 1/16" Stainless Steel Washer. Do not tighten lock nut past locking feature—it binds hinges.
- ⑨ Oilite Bushing
- ⑩ Sign Mounting Sets, consisting of two each 5/16"-18x1" Stainless Steel Hex Head Bolt with Stainless Steel Hex Lock Nut. Two holes on 1/2" centers provide positive lock sign mounting to bracket.

APPROVED

12-1-88

S. E. Rowe

GENERAL MANAGER

**MAST ARM STREET NAME
SIGN BRACKET TYPE 1**

1

1

CITY OF LOS ANGELES
DEPARTMENT OF TRANSPORTATION
S. E. Rowe, General Manager

DWN. HH

T.E.

PR. T.E.

CKD.

SR. T.E.

S-457.0

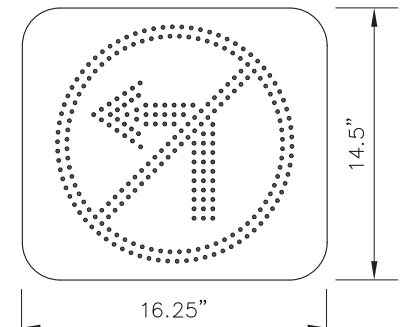

(Pedestrian Head Sign)

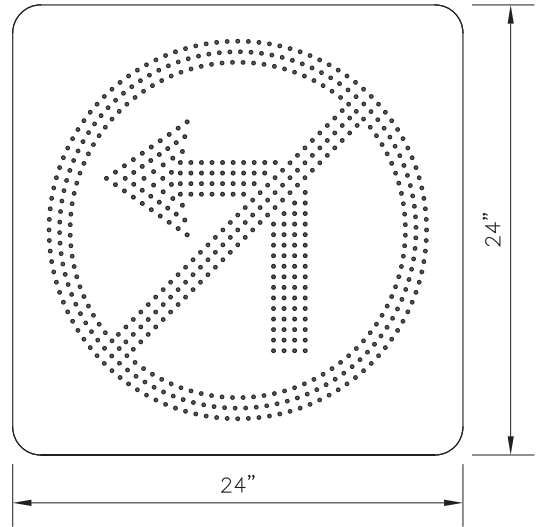

SIGN FACE
Not To Scale

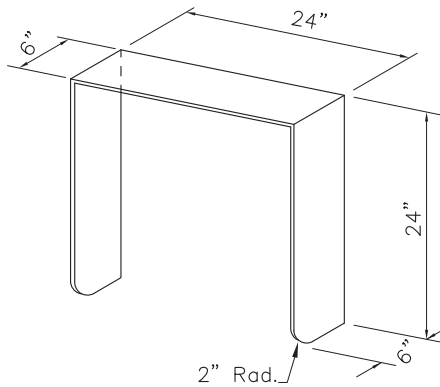

VISOR ENCLOSURE
Not To Scale

Notes:

- Sign shall be capable of displaying the following messages:
R3-1 (No Right Turn symbol), R3-2 (No Left Turn symbol)
Message Colors:
Red – Circle & Diagonal. Width of Circle and Diagonal – 1.5 " stroke – 3 pixel
Lunar White – Left Arrow or Right Arrow. Width of Arrow – 2" stroke – 4 Pixel
- The "NO LEFT TURN" and "NO RIGHT TURN" symbols shall be formed by rows of fiber optic bundles spaced 0.50 inch (center to center).
- Fiber optic bundles shall alternate between two or more lamp sources so that in the event of a lamp failure the sign shall continue to display a discernible and readable message.
- Refer to LADOT STD. DWG. No. S-63.1.4 for mounting assembly.
- Sign shall conform to LADOT Specification No. 82-049-03.
- For housing description, see LADOT STD. DWG. S-58.21
- 24" X 24" electric sign shall include a visor enclosure as shown.
- Lamps shall be solid state, 7W maximum.

DWN	MT	7-9-09	Title NO LEFT & NO RIGHT TURN ELECTRIC SIGN	
CKD				
T. E.	JV	7-16-09		
Sr. T. E.	JW	7-21-09	CITY OF LOS ANGELES DEPARTMENT OF TRANSPORTATION	
Pr. T. E.	SS	7-22-09		
Approved		July 24, 2009		Drawing No.
for		Rita L. Robinson, General Manager		S-58.13

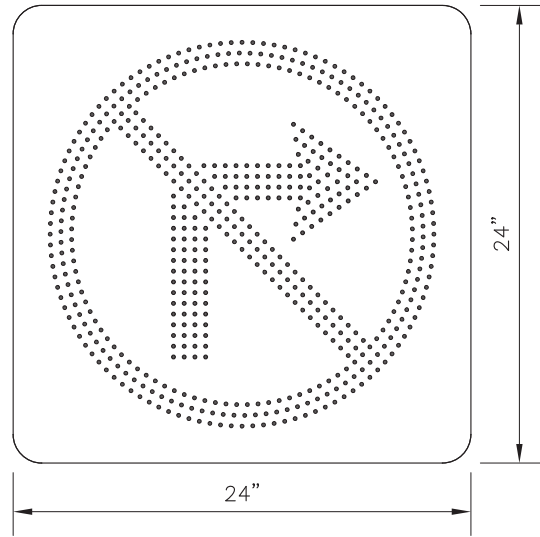
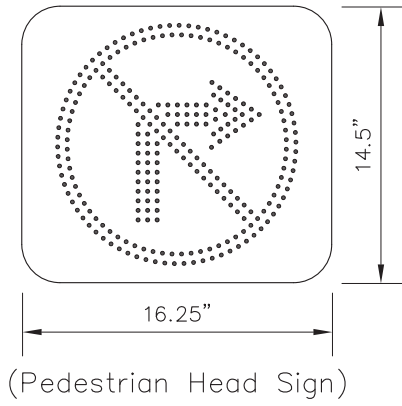

SIGN FACE

Not To Scale

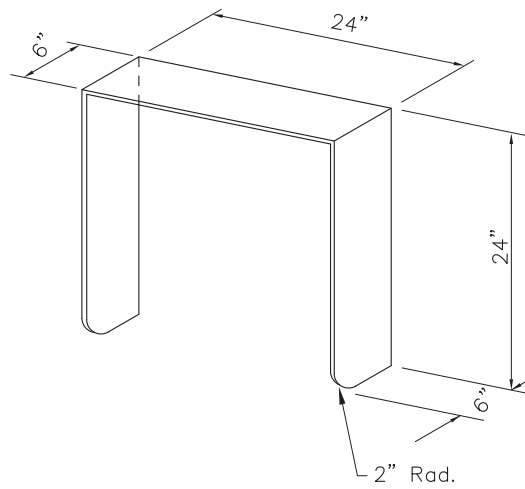

VISOR ENCLOSURE

Not To Scale

CITY OF LOS ANGELES
DEPARTMENT OF TRANSPORTATION

Title **NO LEFT & NO RIGHT TURN
ELECTRIC SIGN**

Drawing No.
S-58.13

2
2

REGULAR PEDESTRIAN SIGNAL HEADS

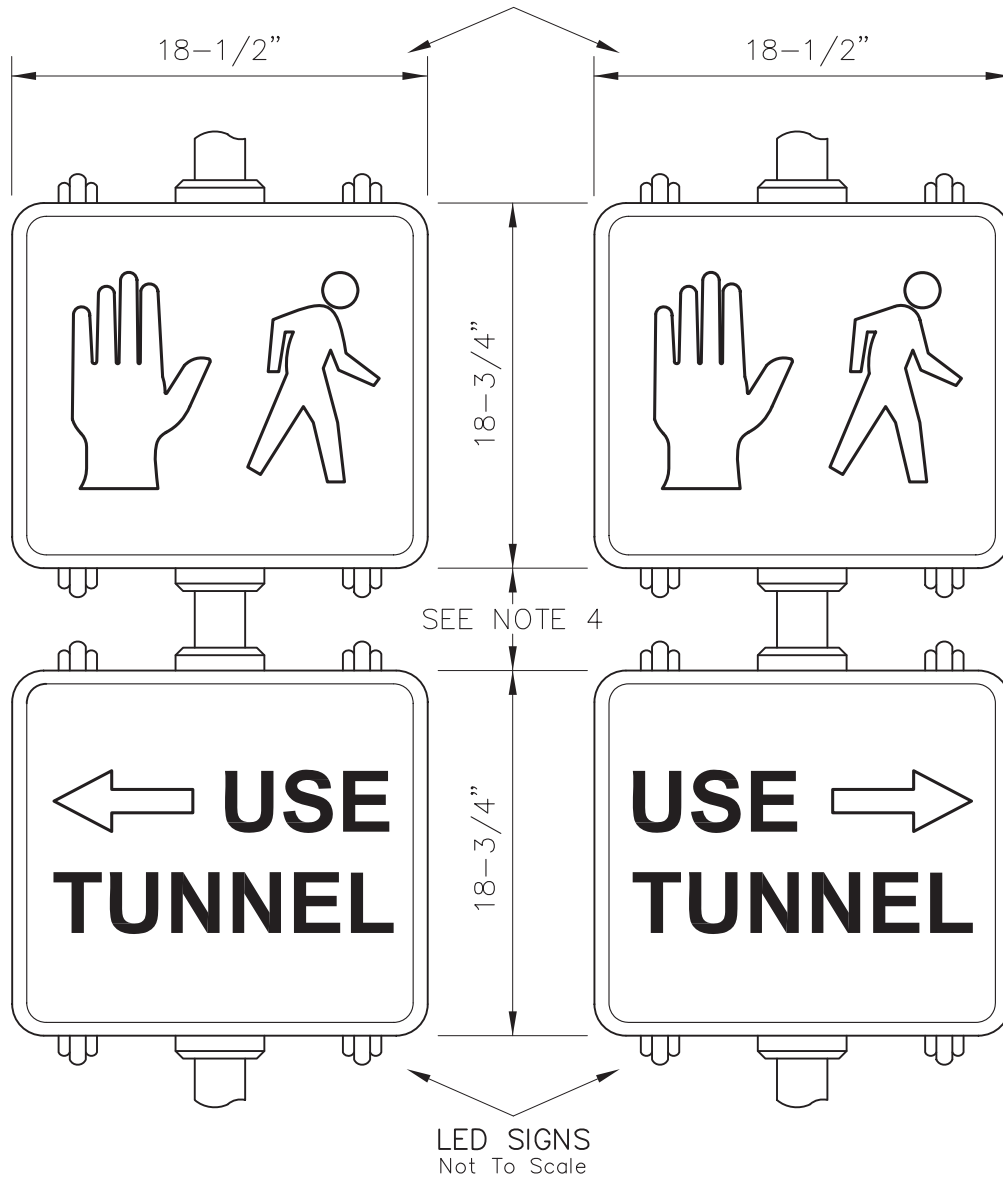

NOTES:

1. THE "USE TUNNEL" SIGN SHALL BE INTERNALLY ILLUMINATED BY SUPER LED DIODES. THE DIODES SHALL EMIT RED COLORED LIGHT. THE SIGN BACKGROUND SHALL BE BLACK.
2. THE SIGN MESSAGE "USE TUNNEL" SHALL BE 4" IN HEIGHT WITH BRUSH STROKE WIDTH OF 1/2". THE ARROW SHALL BE 6-1/2" LONG WITH BRUSH STROKE WIDTH OF 1".
3. THE SIGN HOUSING SHALL CONSIST OF TWO (2) STANDARD* PEDESTRIAN SIGNAL ENCLOSURES CONNECTED TO ONE ANOTHER IN A VERTICAL MANNER.
4. MINIMUM SPACE SHALL BE PROVIDED TO ALLOW FREE MOVEMENT OF DOOR OPENINGS.
5. THE "USE TUNNEL" ELECTRIC SIGN SHALL BE DISPLAYED ONLY WITH THE HAND SYMBOL OF THE PEDESTRIAN SIGNAL HEAD.

* MEETING LADOT SPECIFICATIONS

Drawn By	LAR	03-05-92	Title "USE TUNNEL" ELECTRIC SIGN
Checked By	KHC	03-11-92	
Supervised By	ERA	03-11-92	
Reviewed By	JEF	03-18-92	
Revisions			CITY OF LOS ANGELES DEPARTMENT OF TRANSPORTATION S. E. ROWE, General Manager
			Approved <u>3-18-92</u> S. E. Rowe General Manager
			DRAWING NO. S-58.14

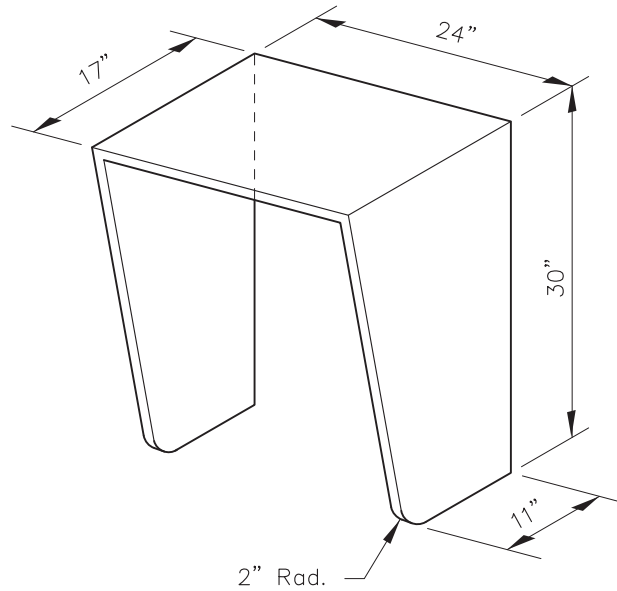
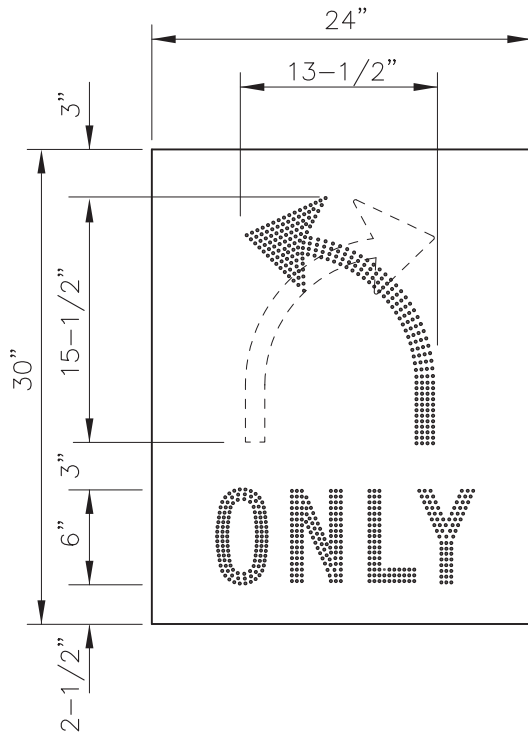

VISOR ENCLOSURE

NOTES:

1. SIGN SHALL BE CAPABLE OF DISPLAYING THE FOLLOWING MESSAGES:
 A: LUNAR WHITE - R3-5L (LEFT ARROW W/ONLY). WIDTH OF ARROW - 1.5" STROKE
 B: LUNAR WHITE - R3-5R (RIGHT ARROW W/ONLY). LETTERS ARE SERIES "C", 1" STROKE
2. MESSAGES SHALL BE FORMED WITH ROWS OF FIBER OPTIC BUNDLES.
 SPACED 0.50 INCH (CENTER TO CENTER).
3. FIBER OPTIC BUNDLES SHALL ALTERNATE BETWEEN TWO OR MORE LAMP SOURCES SO THAT IN THE EVENT OF A LAMP FAILURE THE SIGN SHALL CONTINUE TO DISPLAY A DISCERNABLE AND READABLE MESSAGE.
4. SIGN SHALL COMPLETELY BLANK OUT WHEN NOT ENERGIZED.
5. DOOR FRAME, FACE PLATE, AND INTERIOR OF HOUSING AND VISOR SHALL BE PAINTED FLAT BLACK NON-REFLECTIVE FINISH.
6. VISOR ENCLOSURE SHALL BE FASTENED SECURELY TO THE FRONT FRAME OF THE SIGN.
7. REFER TO LADOT STD. DWG. NO. S-63.1.4 FOR MOUNTING ASSEMBLY.
8. SIGN SHALL CONFORM TO LADOT SPECIFICATION NO. 82-049-03.
9. FOR HOUSING DESCRIPTION, SEE LADOT STD. DWG. NO. S-58.21.

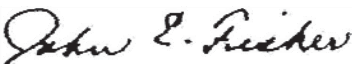
DWN	MT	7-08-08	Title R3-5 ELECTRIC SIGN 1/1
CKD	RAR	7-09-08	
T. E.	JV	7-09-08	
Sr. T. E.	JW	7-09-08	
Pr. T. E.	SS	7-09-08	
CITY OF LOS ANGELES DEPARTMENT OF TRANSPORTATION			
Approved		July 9, 2008	Drawing No.
 for Rita L. Robinson, General Manager			S-58.17

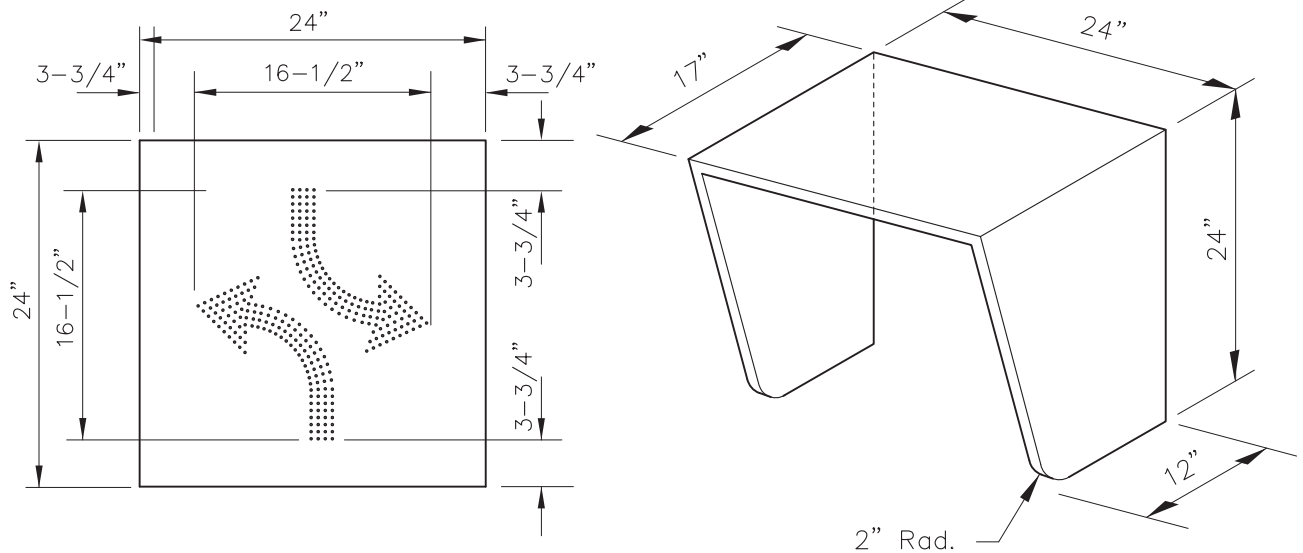

VISOR ENCLOSURE

NOTES:

1. SIGN SHALL BE CAPABLE OF DISPLAYING THE FOLLOWING MESSAGES:
A: LUNAR WHITE - R3-9a (LEFT ARROWS) WIDTH OF ARROWS - 1.5" STROKE
2. MESSAGES SHALL BE FORMED WITH ROWS OF FIBER OPTIC BUNDLES. SPACED 0.50 INCH (CENTER TO CENTER).
3. FIBER OPTIC BUNDLES SHALL ALTERNATE BETWEEN TWO OR MORE LAMP SOURCES SO THAT IN THE EVENT OF A LAMP FAILURE THE SIGN SHALL CONTINUE TO DISPLAY A DISCERNABLE AND READABLE MESSAGE.
4. SIGN SHALL COMPLETELY BLANK OUT WHEN NOT ENERGIZED.
5. DOOR FRAME, FACE PLATE, AND INTERIOR OF HOUSING AND VISOR SHALL BE PAINTED FLAT BLACK NON-REFLECTIVE FINISH.
6. VISOR ENCLOSURE SHALL BE FASTENED SECURELY TO THE FRONT FRAME OF THE SIGN.
7. REFER TO LADOT STD. DWG. NO. S-63.1.4 FOR MOUNTING ASSEMBLY.
8. SIGN SHALL CONFORM TO LADOT SPECIFICATION NO. 82-049-03.
9. FOR HOUSING DESCRIPTION, SEE LADOT STD. DWG. NO. S-58.21.

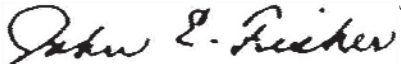
DWN	MT	7-01-08	Title R3-9a ELECTRIC SIGN 
CKD	RAR	7-09-08	
T. E.	JV	7-09-08	
Sr. T. E.	JW	7-09-08	
Pr. T. E.	SS	7-09-08	
CITY OF LOS ANGELES DEPARTMENT OF TRANSPORTATION			
Approved		July 9, 2008	
		Drawing No.	
for Rita L. Robinson, General Manager		S-58.19	

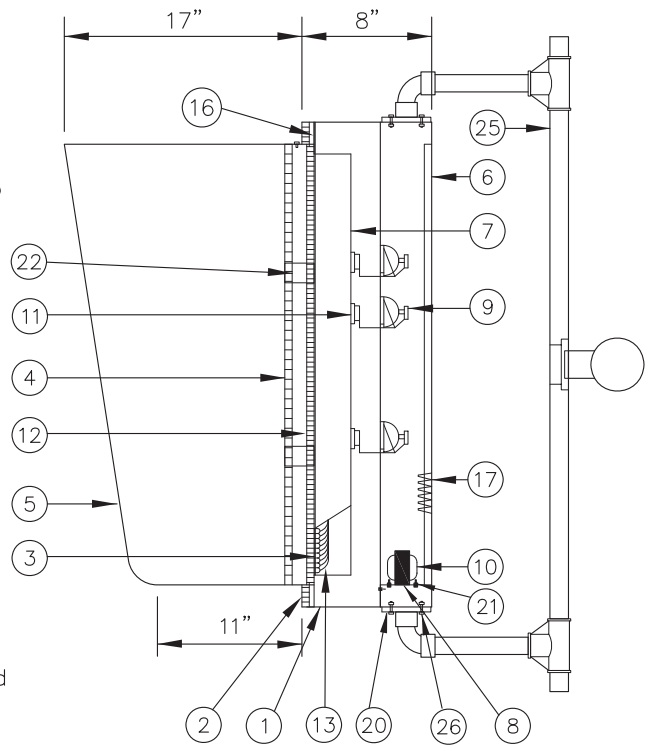
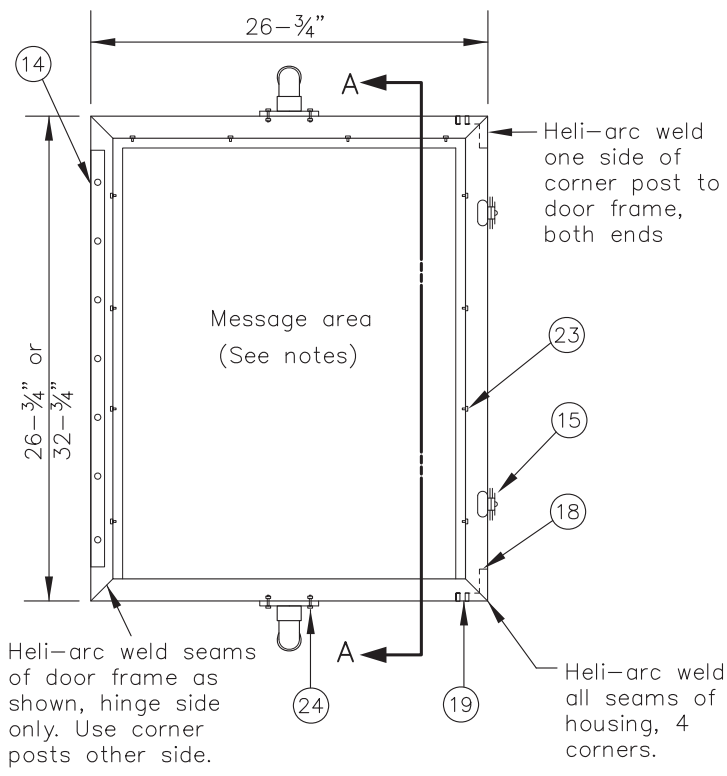

SECTION A-A

ITEM	DESCRIPTION	QTY.
1	HOUSING, .125" EXTRUDED ALUMINUM	1
2	DOOR FRAME, .125" EXTRUDED ALUMINUM	1
3	FACE PLATE, .08" ALUMINUM	1
4	MATTE/CLEAR POLYCARBONATE LENS, .125" THICK	1
5	VISOR .063" ALUMINUM	1
6	BACK PLATE, .063" ALUMINUM	1
7	OPTICS ENCLOSURE, .02" ALUMINUM	1
8	TRANSFORMER SHELF, .063" ALUMINUM	1
9	LAMPS, SOLID STATE 7W MAX.	AS REQ.
10	TRANSFORMERS, 120 VAC PRI., 12 VAC 25 VA SEC.	AS REQ.
11	COMMON ENDS (LIGHT INPUT), ALUMINUM	AS REQ.
12	END TIPS (LIGHT OUTPUTS), NYLON	AS REQ.
13	FIBER OPTIC GLASS BUNDLES, DIA. VARIES	AS REQ.
14	CONTINUOUS HINGE, 1-1/4" (OPEN) X .040" STAINLESS STEEL	1
15	1/4-TURN LINK LOCKS, STAINLESS STEEL	3
16	DOOR GASKET, 1" X 3/16" NEOPRENE (ALL SIDES CONTINUOUS)	1
17	TERMINAL BLOCK (3 PT.)	1
18	CORNER POSTS, ALUMINUM	2
19	#8 X 5/16" SLOTTED PAN HEAD SCREWS, STAINLESS STEEL	AS REQ.
20	4 1/2" X 4 1/2" X 1/4" REINFORCEMENT ALUMINUM PLATE (SEE DETAIL "A")	2
21	#8 -32 X 3/4" SLOTTED ROUND HEAD MACHINE SCREW, HEX NUTS & LOCK WASHERS (STAINLESS STEEL)	32
22	LENS STIFFENER BLOCKS, ACRYLIC	2
23	5/16" X 1-1/4" HEX HEAD MACHINE SCREW BOLT & HEX NUT VISOR SCREWS (STAINLESS STEEL)	12
24	5/16" X 1" HEX HEAD MACHINE SCREW BOLT & HEX NUT & LOCK WASHERS (STAINLESS STEEL)	8
25	MOUNTING BRACKET	1
26	1/2" WIRE ENTRY BUSHING	1

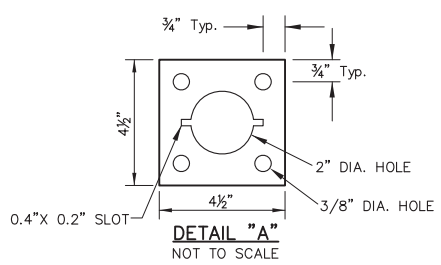

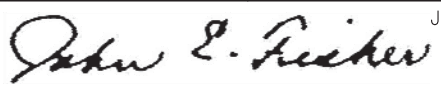
DWN	MT	11-07-07	Title
CKD			SIGN ENCLOSURE
T. E.			CITY OF LOS ANGELES
Sr. T. E.			DEPARTMENT OF TRANSPORTATION
Pr. T. E.	SS	6-26-08	Approved
			June 26, 2008
for Rita L. Robinson, General Manager			DRAWING NO. S-58.21

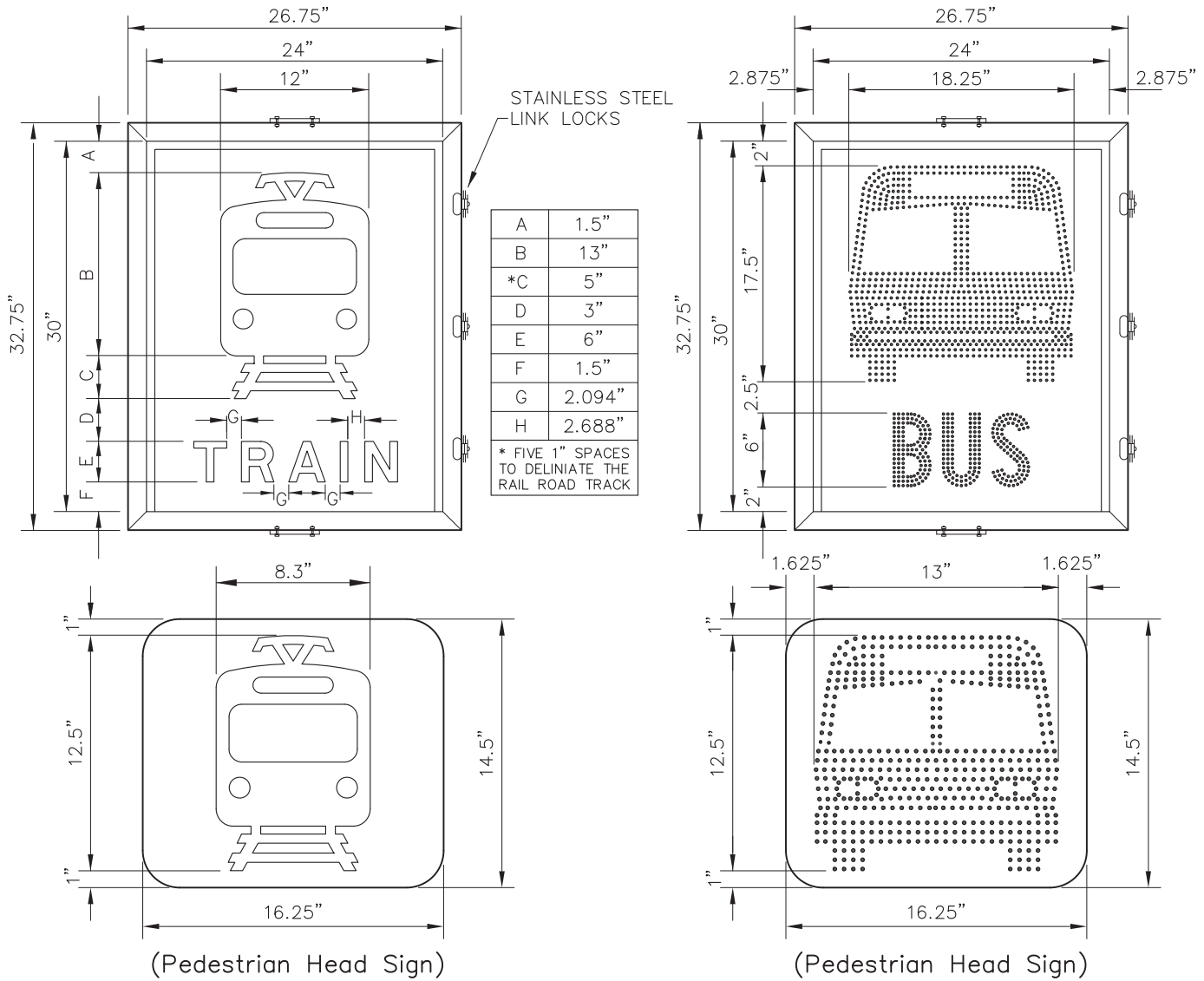

- NOTES:**
1. MESSAGES SHALL BE FORMED BY ROWS OF FIBER OPTIC GLASS BUNDLES.
 2. DUAL ROWS OF FIBER OPTIC BUNDLES SHALL BE USED TO FORM THE WORD "TRAIN". LETTERS IN THE BUS WARNING SIGN MESSAGE SHALL HAVE A BRUSH STROKE OF 1-INCH. BUS SYMBOL AND LETTERS SHALL ALSO CONFORM TO THE LATEST EDITION OF THE FHWA STANDARD HIGHWAY SIGNS BOOK.
 3. THE FRONT VIEW OF THE TRAIN OR BUS SHALL BE SOLID FORMED BY ROWS OF FIBER OPTIC GLASS BUNDLES.
 4. THE COLOR OF THE MESSAGES SHALL BE YELLOW. THE SIGN BACKGROUND SHALL BE BLACK.
 5. FIBER OPTIC GLASS BUNDLES SHALL ALTERNATE BETWEEN TWO OR MORE LAMP SOURCES. IN THE EVENT OF A LAMP FAILURE, THE SIGN SHALL CONTINUE TO DISPLAY A READABLE AND DISCERNABLE MESSAGE.
 6. SIGN HOUSING SHALL BE EQUIPPED WITH FOUR (4) 3/16" DRAIN HOLES AT THE BOTTOM.
 7. THE VISOR ENCLOSURE SHALL BE FASTENED SECURELY TO THE FRONT FRAME OF THE SIGN.
 8. HOUSING SHALL CONTAIN 4 1/2" X 4 1/2" X 1/4" REINFORCEMENT PLATE LOCATED ON THE TOP AND BOTTOM FOR USE WITH THE PELCO ASTRO SIGN-BRAC INSTALLATION.
 9. REFER TO STD. DWG. NO. S-63.1.4 FOR THE MOUNTING ASSEMBLY (T=46", L=29").
 10. SIGN SHALL CONFORM TO LADOT SPECIFICATION No. 82-049-03.
 11. FOR HOUSING DESCRIPTION SEE LADOT STD. DWG. NO. S-58.21

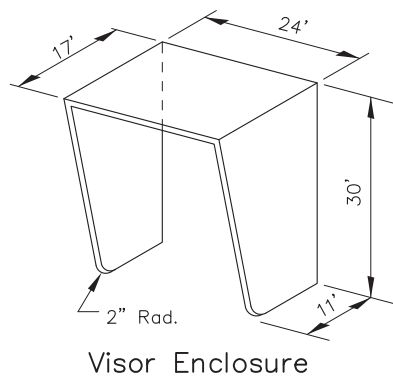

DWN	MT	4-16-08	Title
CKD			ELECTRIC TRAIN & BUS WARNING SIGN
T. E.			CITY OF LOS ANGELES
Sr. T. E.			DEPARTMENT OF TRANSPORTATION
Pr. T. E.	SS	6-26-08	
Approved	<i>John E. Fisher</i>		June 26, 2008
for	Rita L. Robinson, General Manager		DRAWING NO.
			S-58.23

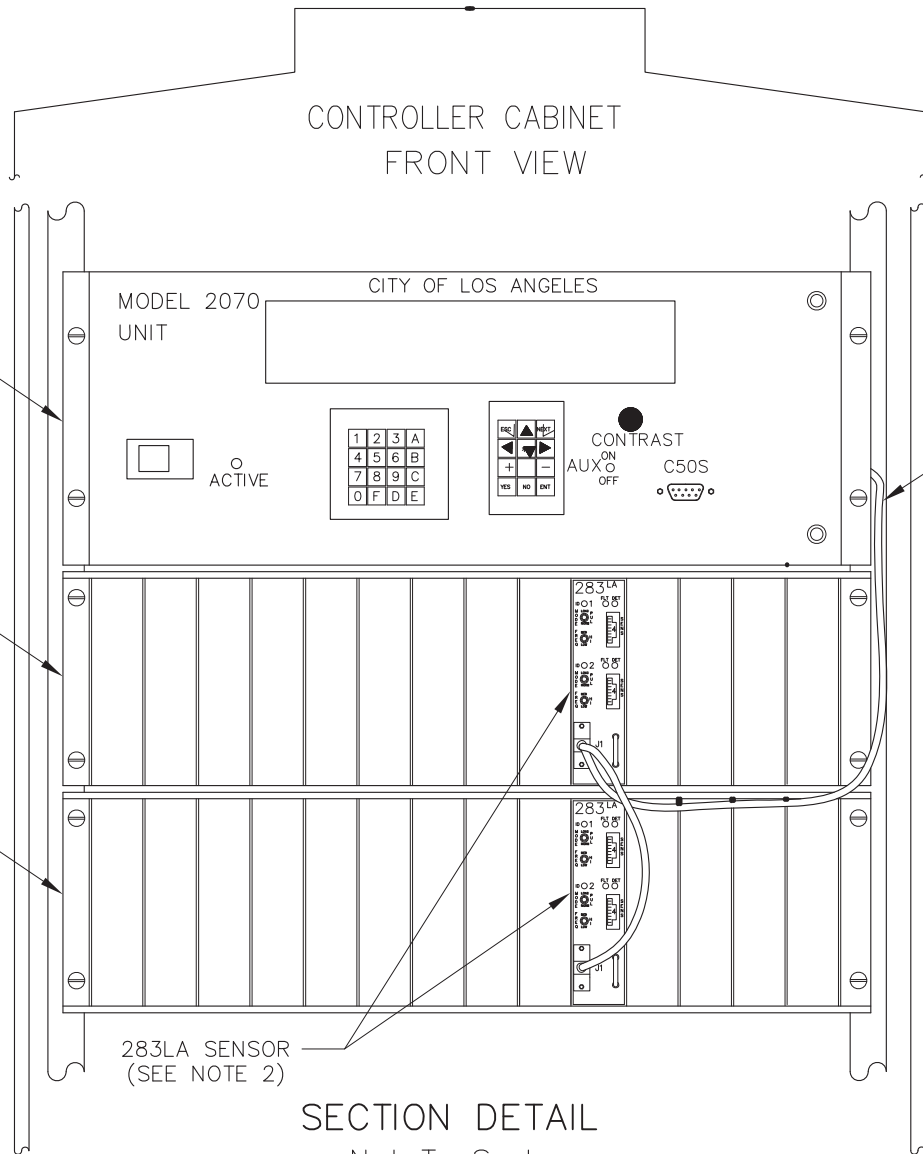

CONTROLLER CABINET
FRONT VIEW

MODEL 2070
UNIT

CITY OF LOS ANGELES

2070
CONTROLLER

ACTIVE

CONTRAST
AUX ON
OFF C50S

DB9 SERIAL CABLE
(SEE NOTE 3)

SEE SHEET 5/6

INPUT FILE I

INPUT FILE J

283LA SENSOR
(SEE NOTE 2)

SECTION DETAIL
Not To Scale

NOTES:

1. THIS DRAWING DEPICTS A TWO SENSOR CONFIGURATION. EACH SENSOR CAN ACCOMODATE UP TO TWO LOOPS.
2. INSTALL 283LA TRANSIT SENSORS IN SLOTS 10 OF THE I & J INPUT FILES. CONNECT SENSOR CABLE ENDS (B1/B2, B3/B4) TO THE SENSOR J1 SERIAL PORTS.
3. ROUTE SERIAL COMMUNICATIONS CABLE BEHIND CABINET CHASIS. CONNECT 2070 CABLE END TO THE 2070 C21S PORT. SECURE CABLE TO CABINET CHASIS WITH WIRE TIES.

DWN	AN	12-01-01	Title TRANSIT PRIORITY UNIT CABINET DETAIL	
CKD	AN	12-01-01		
T. E.	SS	01-01-01		
Sr. T. E.	SS	01-01-01		
Pr. T. E.	GO	2-14-01		
Approved			CITY OF LOS ANGELES DEPARTMENT OF TRANSPORTATION	
 Frances T. Banerjee, General Manager		2/20/2001	DRAWING NO. S-70.3A	

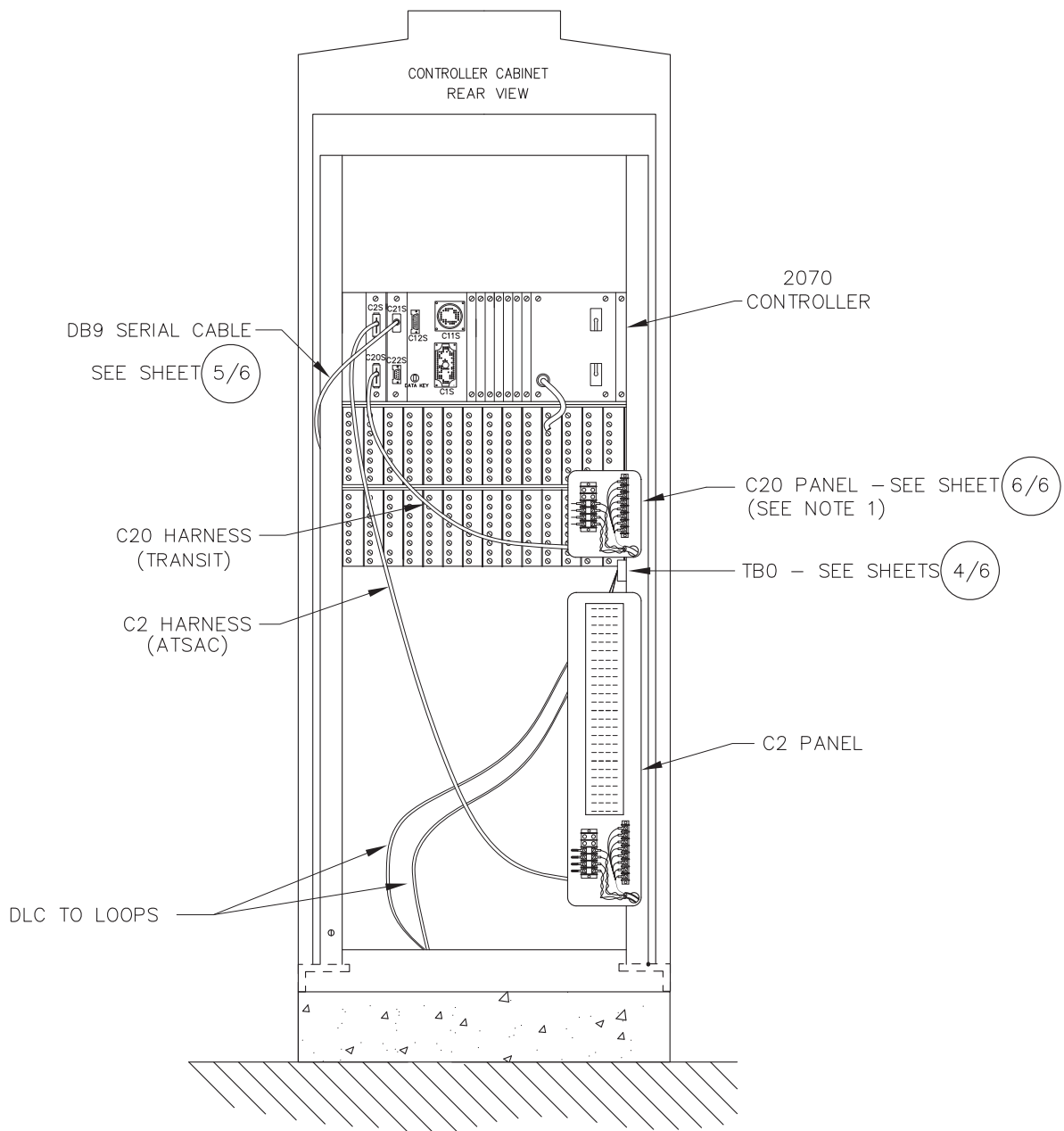

SECTION DETAIL
Not To Scale

NOTE:
1. INSTALL C20 HARNESS AND PANEL
ON RACK ABOVE C2 PANEL.

CONTROLLER CABINET REAR VIEW

DB9 SERIAL
CABLE
(SEE NOTE 1)

POWER
CABLE

C20 HARNESS
(SEE NOTE 3
- TRANSIT)
C2 HARNESS
(ATSAC)

INPUT FILE HARNESS
(SEE NOTE 2)

TBO
SEE SHEET 4/6

NOTES:

1. CONNECT 2070 CABLE END TO THE 2070 C21S PORT.
2. INSTALL INPUT FILE HARNESS FROM TBO TO INPUT FILE BACKPLANE.
3. CONNECT C20 HARNESS TO THE C20S PORT.

CITY OF LOS ANGELES
DEPARTMENT OF TRANSPORTATION

Title

TRANSIT PRIORITY UNIT
CABINET DETAIL

3/6

Drawing No.

S-70.3A

12-POSITION DUAL BARRIER STRIP

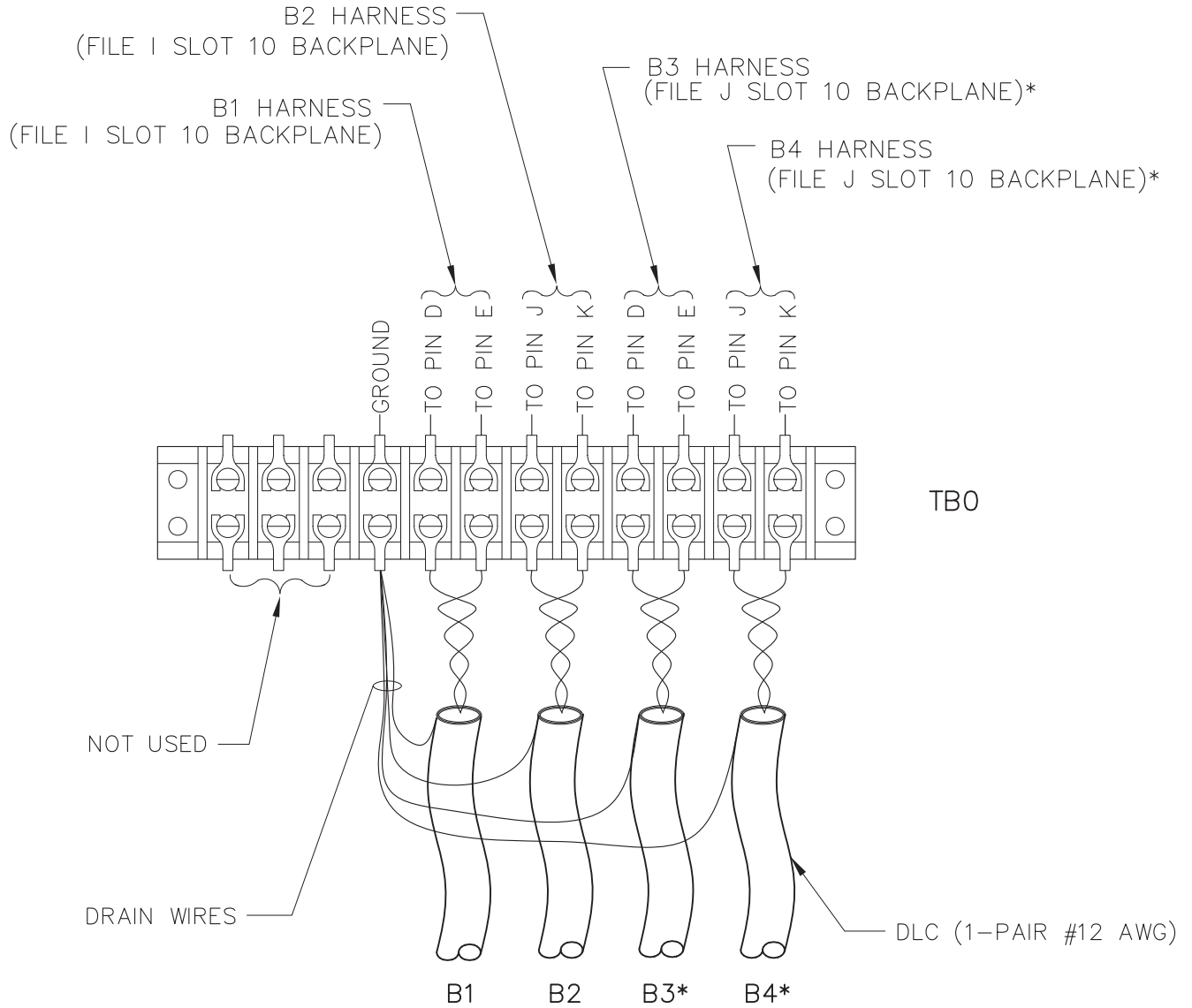

* SECOND HARNESS TO INPUT FILE J IS ONLY REQUIRED FOR 3 AND 4 LOOP INSTALLATION.

NOTE:

1. ALL CONNECTIONS SHALL BE SOLDERED.

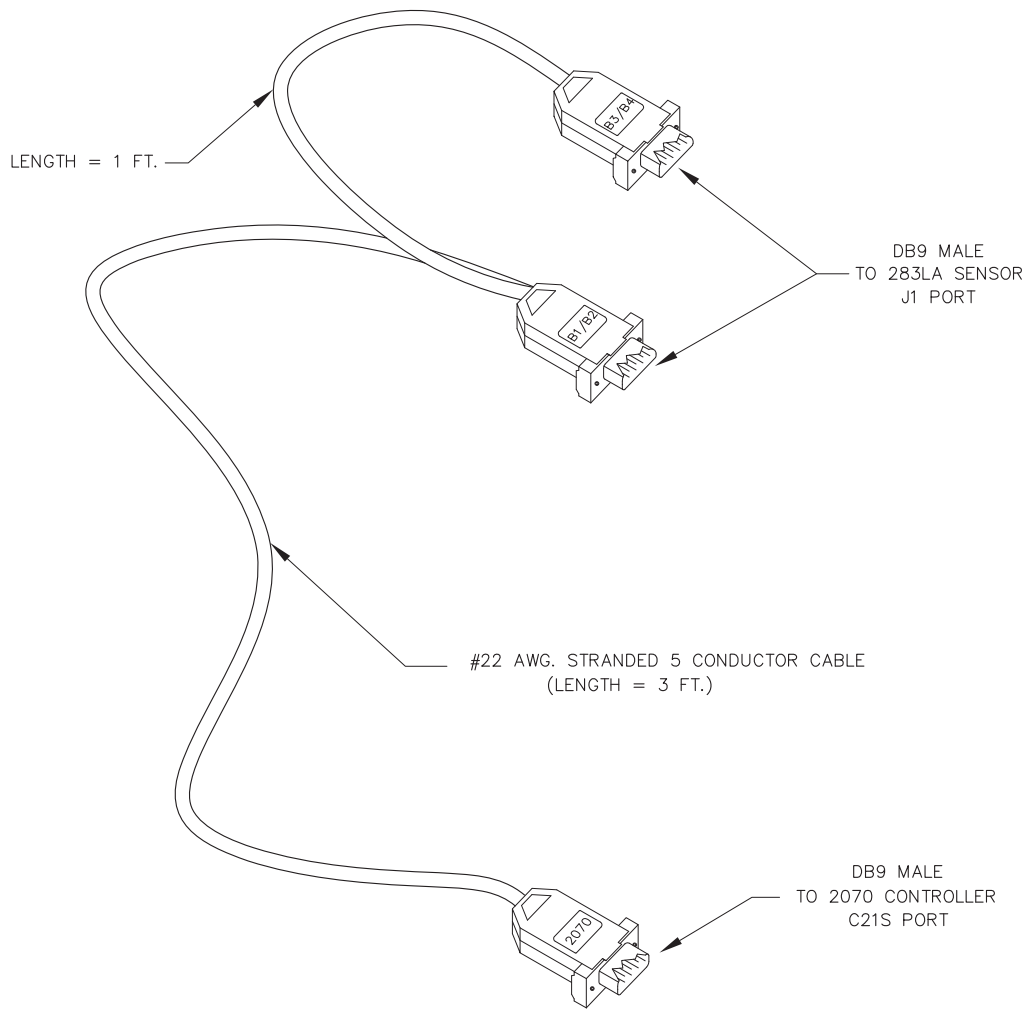

PIN	FUNCTION 2070	FUNCTION 283 LA
1	N/C	N/C
2	TX	RX
3	RX	TX
4	N/C	N/C
5	GND	GND
6	N/C	N/C
7	CTS	RTS
8	RTS	CTS
9	GND	GND

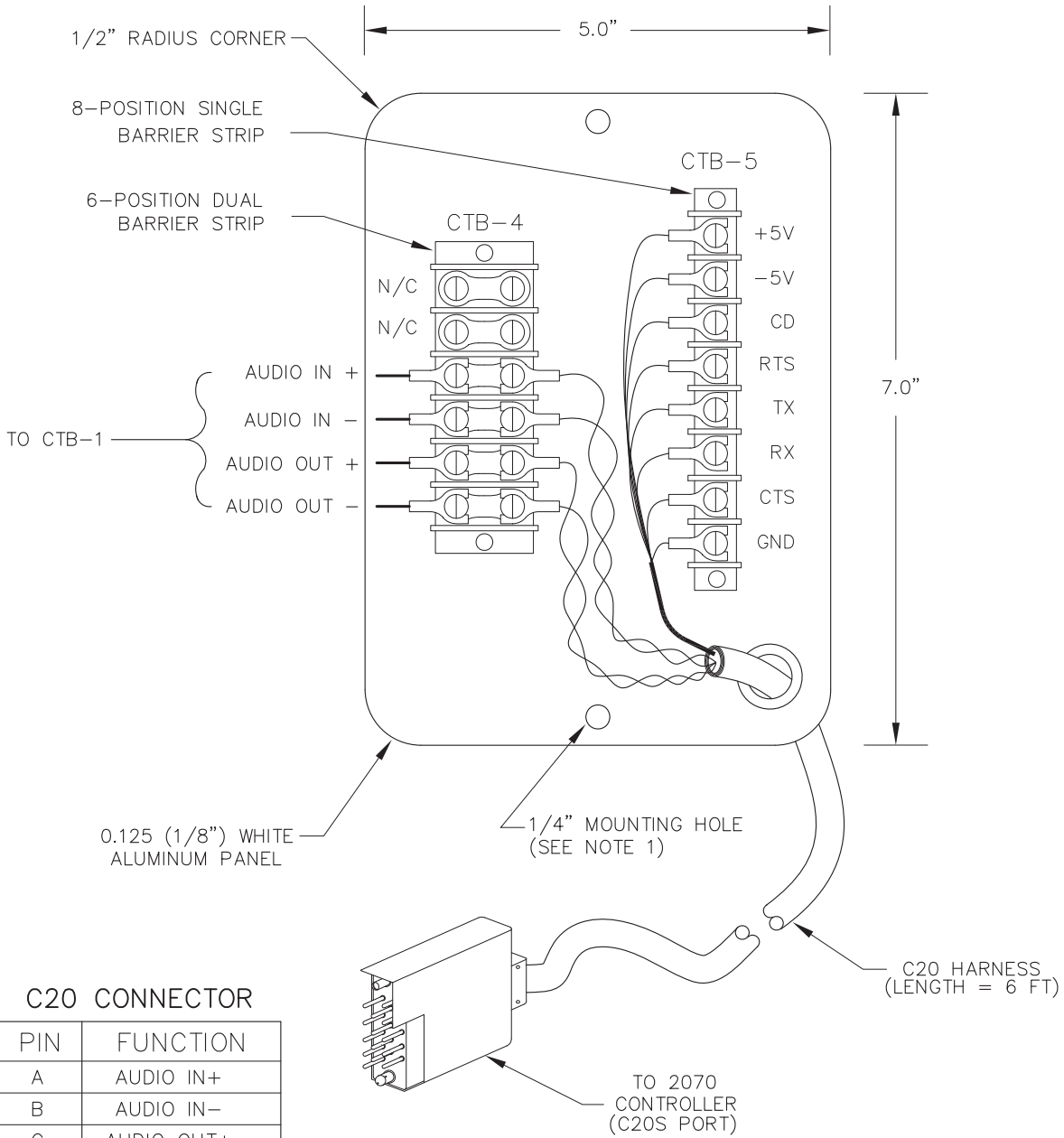

C20 CONNECTOR

PIN	FUNCTION
A	AUDIO IN+
B	AUDIO IN-
C	AUDIO OUT+
D	+5 VDC
E	AUDIO OUT-
F	N/C
H	CD
J	RTS
K	TX
L	RX
M	CTS
N	DC GND
P	N/C
N	N/C

NOTES:

1. PROVIDE TWO (2) 1/4" MOUNTING HOLES CENTERED 0.325" FROM TOP AND BOTTOM EDGES.
2. ALL CONNECTIONS SHALL BE SOLDERED.

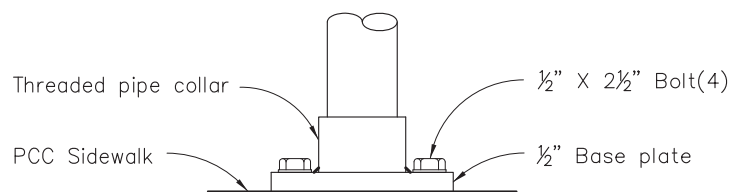
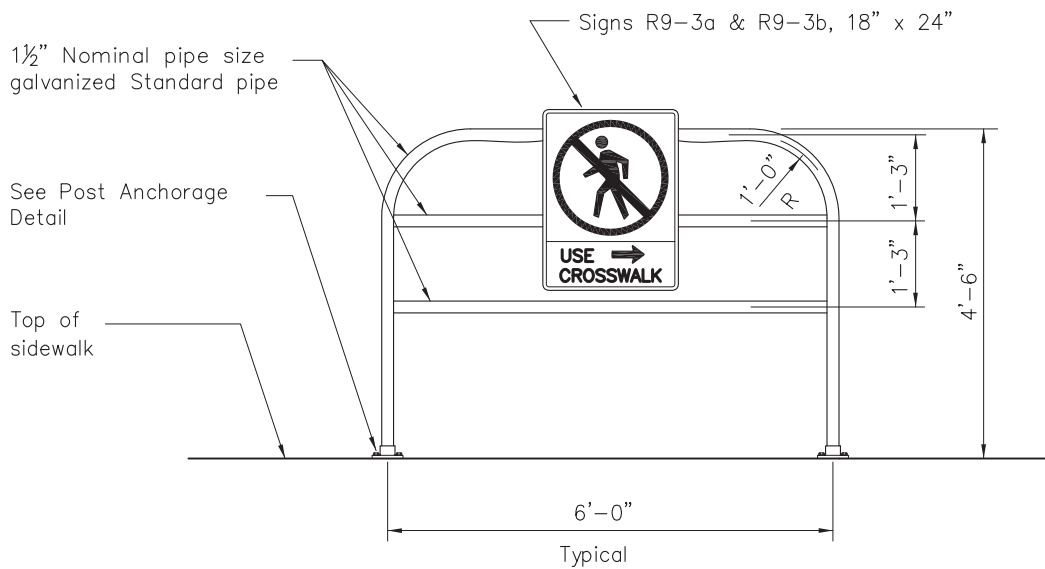

Elevation

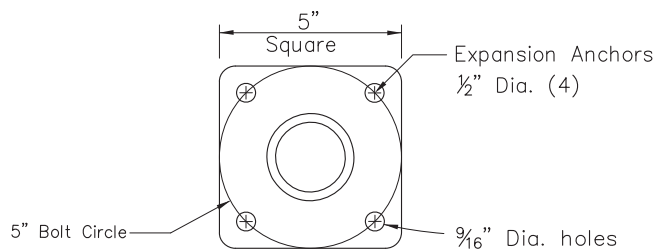

Plan

Post Anchorage Detail

Notes:

1. Pipe post to be set 1'-6" back from face of curb unless otherwise specified.
2. For minimum pipe diameters and wall thickness refer to ASTM A6M.
3. Use left, right or double arrow on sign as needed.

DWN	MT	05-03-06	Title Pedestrian Barricade
CKD			
T. E.			
Sr. T. E.			
Pr. T. E.	SS	06-26-08	CITY OF LOS ANGELES DEPARTMENT OF TRANSPORTATION
Approved		June 26, 2008	Drawing No.
for <i>John E. Fisher</i>			S-454.2
Rita L. Robinson, General Manager			